

ENGINE

1UZ-FE ENGINE

● DESCRIPTION

The 1UZ-FE engine is a V-8, 4.0-liter, 32-valve DOHC engine designed exclusively for the luxury LS400 sedan.

Incorporating the state-of-the-art technology, this engine implements high-speed performance and utility at a high level providing an exciting feeling of a very smooth acceleration response to the pedal operation. With thorough analysis, design and precisely controlled manufacturing, major component parts have been improved to achieve very low vibration and noise level.

The engine operation is accurately-controlled by the ECU (Electronic Control Unit) and maintains peak performance and efficiency at all times.

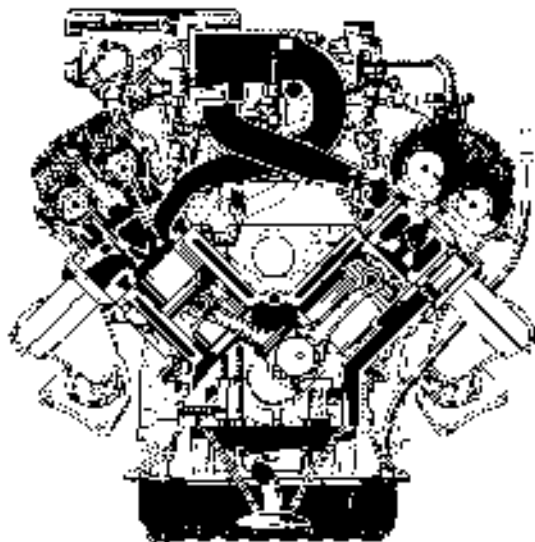
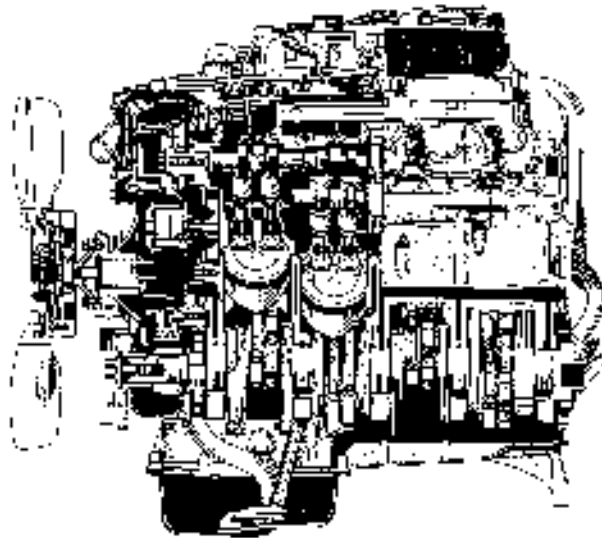

● ENGINE SPECIFICATIONS AND PERFORMANCE CURVE

Engine		1UZ-FE
Item		
No. of Cyls. & Arrangement		8-Cylinder, V Type
Valve Mechanism		32-Valve, DOHC, Belt & Gear Drive
Combustion Chamber		Pentroof Type
Manifolds		Cross-flow
Displacement	cu. in. (cc)	242.1 (3,969)
Bore x Stroke	in. (mm)	3.44 x 3.25 (87.5 x 82.5)
Compression Ratio		10.0 : 1
Firing Order		1-8-4-3-6-5-7-2
Max. Output (SAE-NET)		250 HP @ 5,600 rpm
Max. Torque (SAE-NET)		260 ft-lbs @ 4,400 rpm
Fuel Octane Number (RON)		96
Oil Grade*		API SG, EC-II

* Refer to the next page for detail.

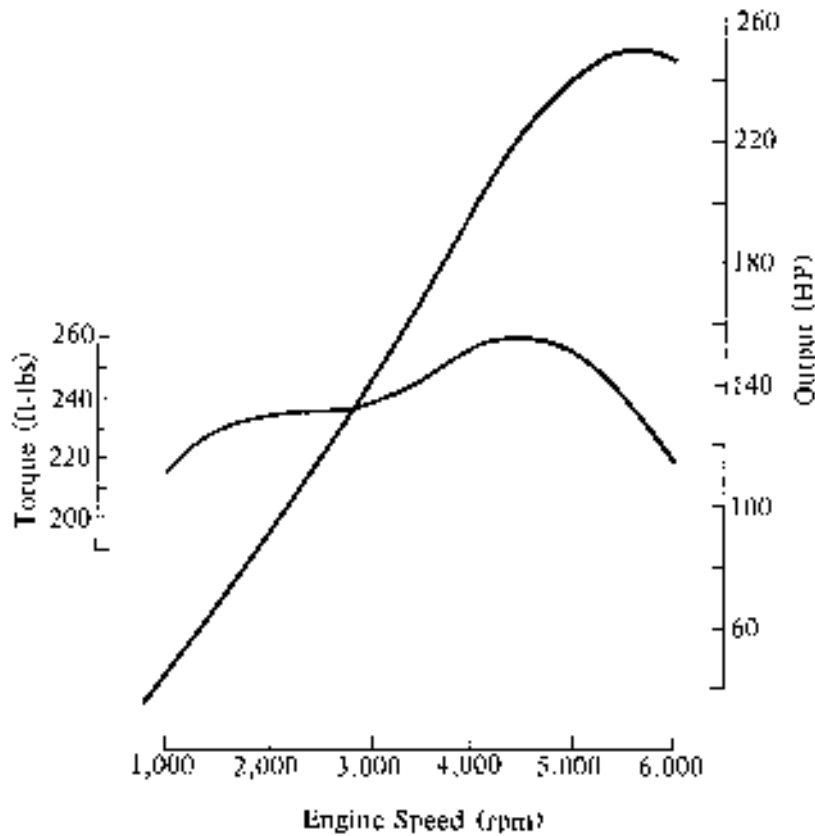

***NOTE:** Engine oil selection

Use API (American Petroleum Institute) grade SG, Energy-Conserving II multigrade engine oil.

Recommended viscosity is as follows, with SAE 5W-30 being the preferred engine oil for the 1UZ-FE engine.

- Recommended Viscosity (SAE)◀

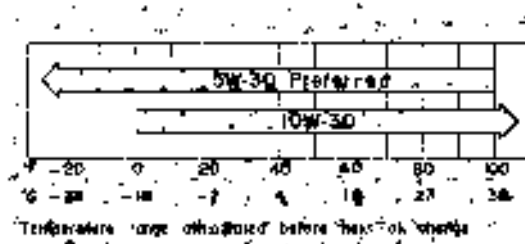

A label is added to the oil filler cap and some oil containers to help you select the oil you should use.

The top portion of the label shows the oil quality by API designations such as SG. The center portion of the label shows the SAE viscosity grade, such as SAE 5W-30.

“Energy-Conserving II” shown in the lower portion, indicates that the oil has fuel-saving capabilities.

- Oil Identification Label◀



Oils marked “Energy-Conserving II” will have higher fuel-saving capabilities than oils marked “Energy-Conserving.”

● FEATURES OF 1UZ-FE ENGINE

Features of the 1UZ-FE engine are shown in the following list:

Features	Contents
High Performance	<ul style="list-style-type: none"> • Compact DOHC, 32-valve, center-firing and high compression ratio combustion chamber implements a high combustion efficiency. • ECU-controlled precise engine operation. • Reduced intake and exhaust losses resulting from large-diameter intake duct, air flow meter, dual exhaust system, etc.
Lightweight and Compact Design	<ul style="list-style-type: none"> • Reduced cylinder head size by the adoption of a scissors gear mechanism. • Cylinder block and oil pan made of aluminum alloy. • Compact, lightweight accessory drive system by means of serpentine, single belt and bracketless accessory installation.
Low Noise and Vibration	<ul style="list-style-type: none"> • Use of an aluminum oil pan having an integral stiffener. • Aluminum engine mount brackets and liquid-filled compound engine mounts. • Silent start type three-stage temperature-controlled auto-coupling fan. • Rigid and accurately balanced crankshaft assembly. • Auto tensioners for timing belt and V-ribbed belt.
Serviceability	<ul style="list-style-type: none"> • Outer shim type valve lifter. • Auto tensioners for timing belt and V-ribbed belt. • Engine oil level sensor.
High Reliability	<ul style="list-style-type: none"> • Thin cast-iron liner press-fit in aluminum cylinder block. • Highly durable timing belt and auto tensioner. • Plastic region tightening bolts in major parts (cylinder head bolts, crankshaft bearing cap bolts, connecting rod cap bolts).

● ENGINE

1. Cylinder Head

- The cylinder head is made of aluminum and has intake and exhaust ports in a cross-flow arrangement. The intake ports are on the inside and the exhaust ports on the outside of the left and right banks respectively.
- The cylinder heads are compact even for a DOHC engine. The pitch of the intake and exhaust camshafts is shortened and the valve angle is narrowed to $21^{\circ}33'$.
- The left and right banks of cylinder heads are common in configuration.

NOTICE

When the cylinder heads are disassembled for servicing, be sure to assemble each cylinder head to the correct right or left bank. The camshaft may seize if they are assembled incorrectly.

- Pentroof type combustion chamber with four valves is used.
- The squish area guides the air-fuel mixture to the center of the combustion chamber to increase the combustion speed and thus maintain a stable engine operation.

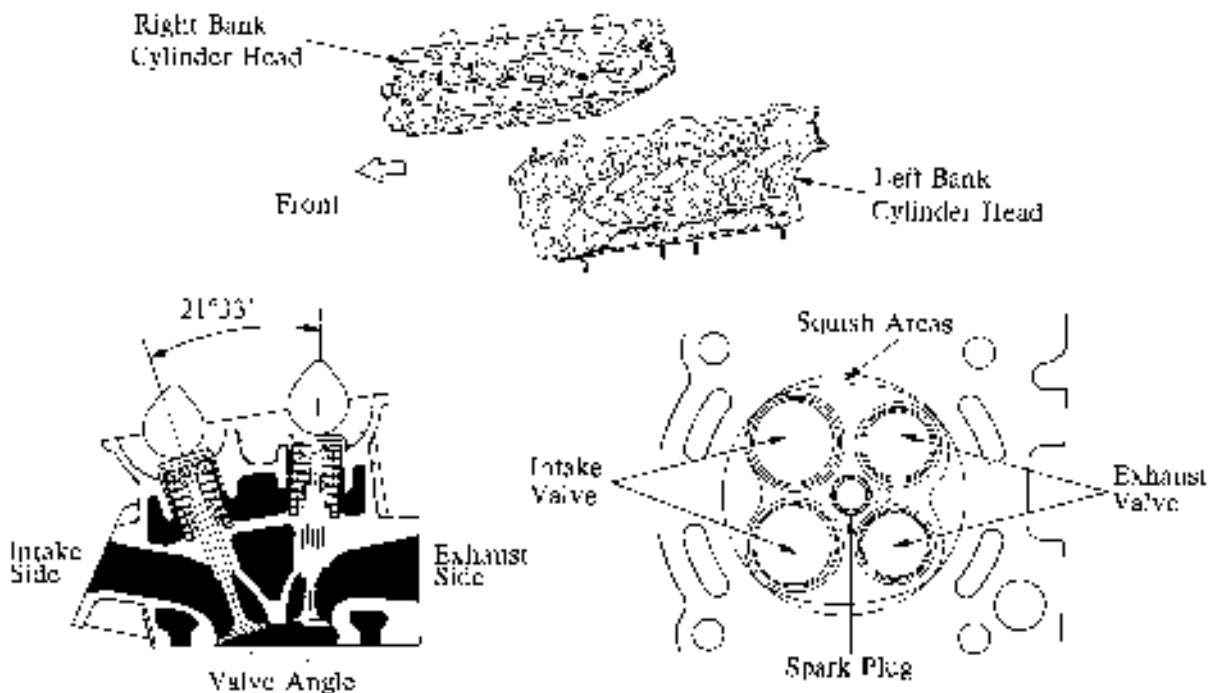

- Plastic region tightening bolts, having a good axial tension stability, are used for securing the cylinder heads to the block.

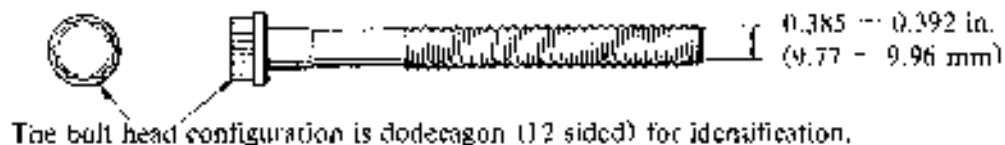

NOTE: When reusing the cylinder head bolts, make sure the diameter at the thread is not less than 0.378 in. (9.6 mm). It will be necessary to replace them with new ones if the diameter is less than specification.

2. Cylinder Block

- The cylinder block has a bank angle of 90° , a bank offset of 0.827 in. (21 mm) and a bore pitch of 4.15 in. (105.5 mm), resulting in a compact block in its length and width even for its displacement.
- Lightweight aluminum alloy is used for the cylinder block.
- A thin cast-iron liner is press-fit inside the cylinder to ensure an added reliability.

NOTICE

Never attempt to machine the cylinder because it has a thin 0.08 in. (2 mm) liner inside.

- Part of the volute chamber of the water pump and the water by-pass passage are incorporated into the cylinder block to shorten the engine length.
- Installation bosses of the two knock sensors are located on the inner side of left and right banks.
- The plastic region tightening bolts are used for the crankshaft bearing caps.

NOTE: When reusing the crankshaft bearing cap bolts, make sure the diameter at the thread is not less than 0.291 in. (7.4 mm). It will be necessary to replace them with new ones if the diameter is less than specification.

- The starter is located inside the V-bank.
- To install a local engine block heater, first remove the cover plate shown in the “A” view drawing below.

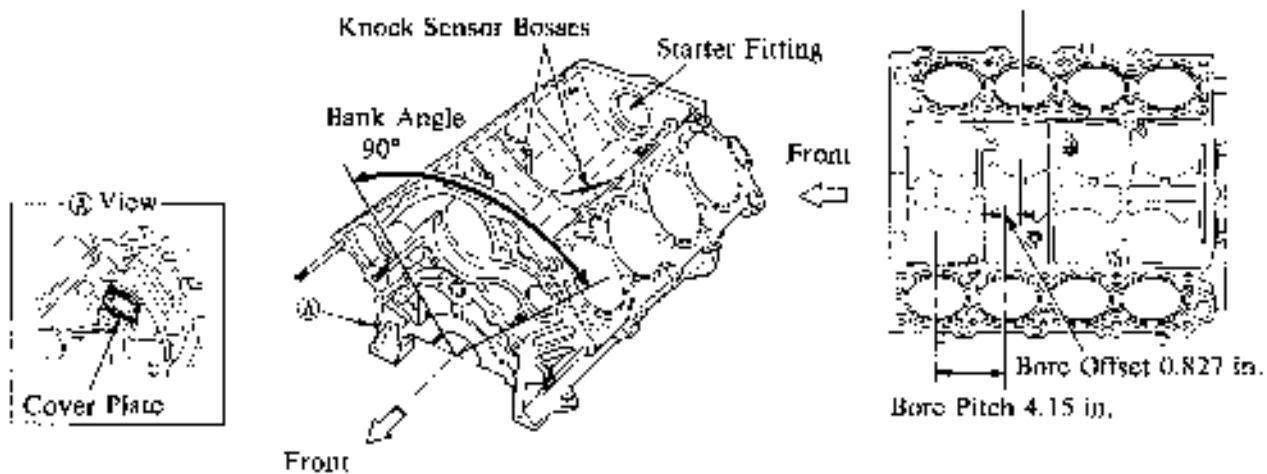

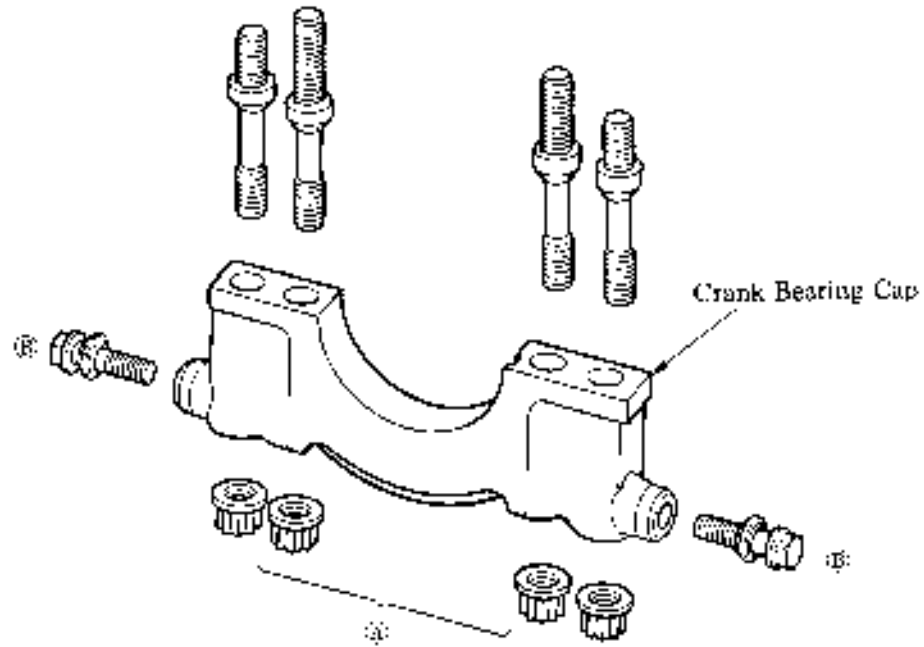
**NOTICE**

When fitting the crankshaft bearing cap, always tighten **A** first and **B** next in order to obtain roundness of the bearing.

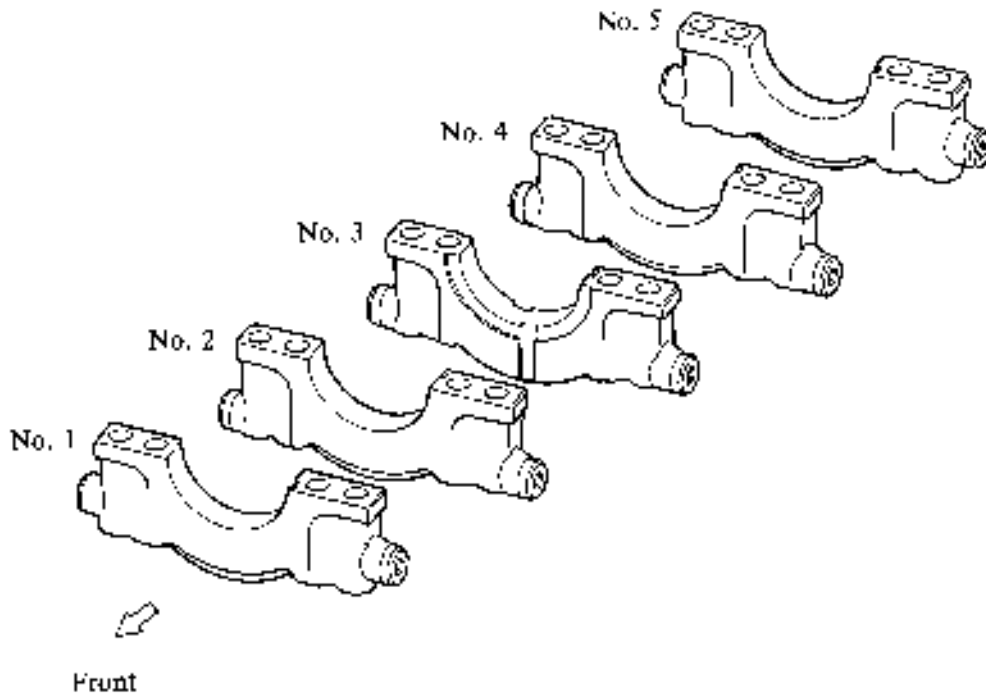

3. Piston

- Steel struts are used to control thermal expansion.
- The skirt of each piston is striation finished (finely grooved) for maintaining proper lubrication and reducing friction loss.
- The piston has a weight-adjusting boss to minimize fluctuation of weight among pistons and balance the engine assembly.
- Piston pins are the full-floating type and are held in place with snap rings.

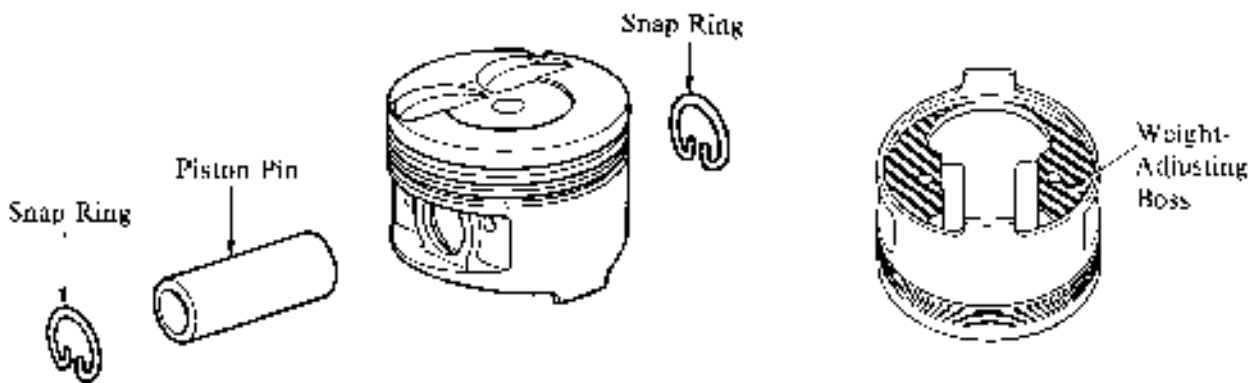
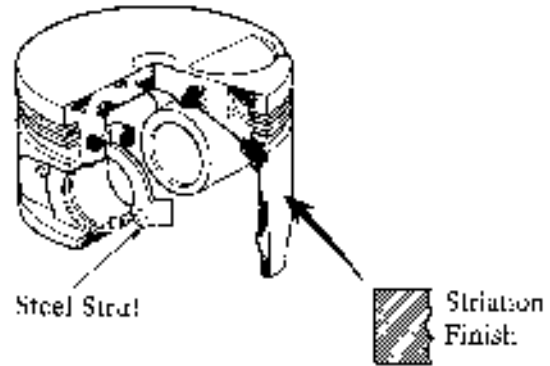

4. Piston Ring

- Each surface of the compression ring No. 1 and the oil ring side rail is nitrified to prevent an increase of oil consumption and blow-by gas as the time elapses.

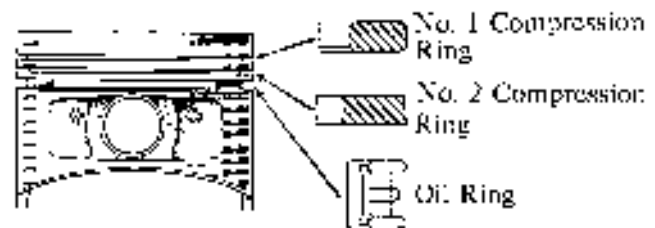

5. Connecting Rod

- The sintered and forged connecting rod is very rigid and has little weight fluctuation.
- A weight-adjusting boss is provided at the big end to reduce fluctuation of weight and balance the engine assembly.
- The connecting rod cap is held by plastic region tightening bolts.

NOTE: When reusing the connecting rod cap bolts, if the diameter at the thread is less than 0.275 in. (7.0 mm), it is necessary to replace them with new ones.

- The connecting rods for the right and left banks are placed in opposite directions with the outer marks facing the crankshaft.

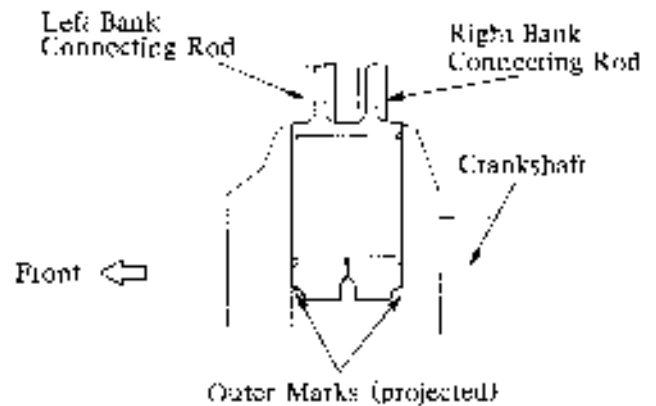
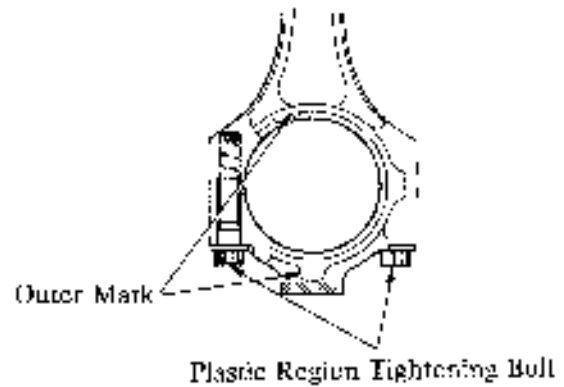
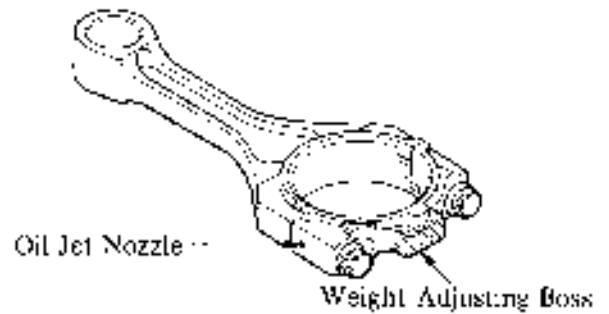

6. Crankshaft and Crankshaft Bearings

- A forged crankshaft with five main journals, four connecting rod pins and eight balance weights is used.
- Connecting rod pins and journals are induction-hardened to ensure an added reliability.

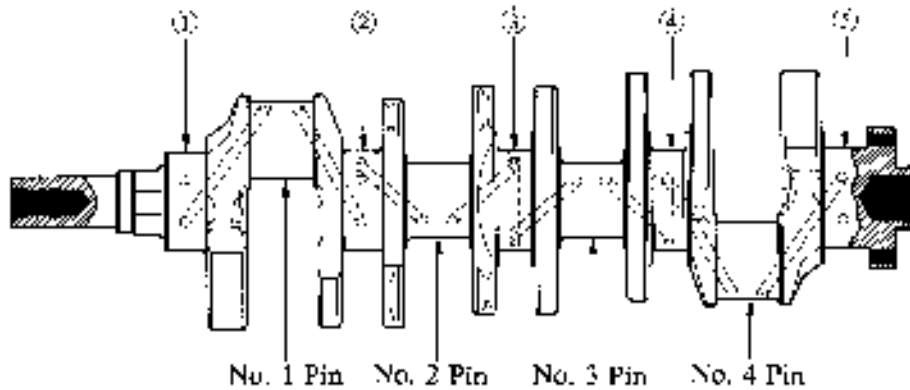

- Bearings are made of kelmet.

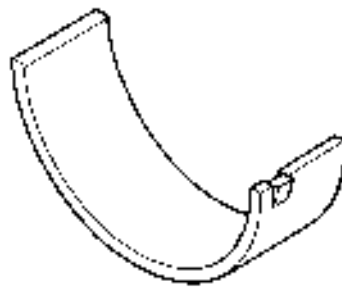

- Crankshaft bearings are selected carefully according to the measured diameters of the crank journal and cylinder block journal holes.

NOTE: The diameter of the crank journal and the cylinder block journal hole is indicated at the places shown below.

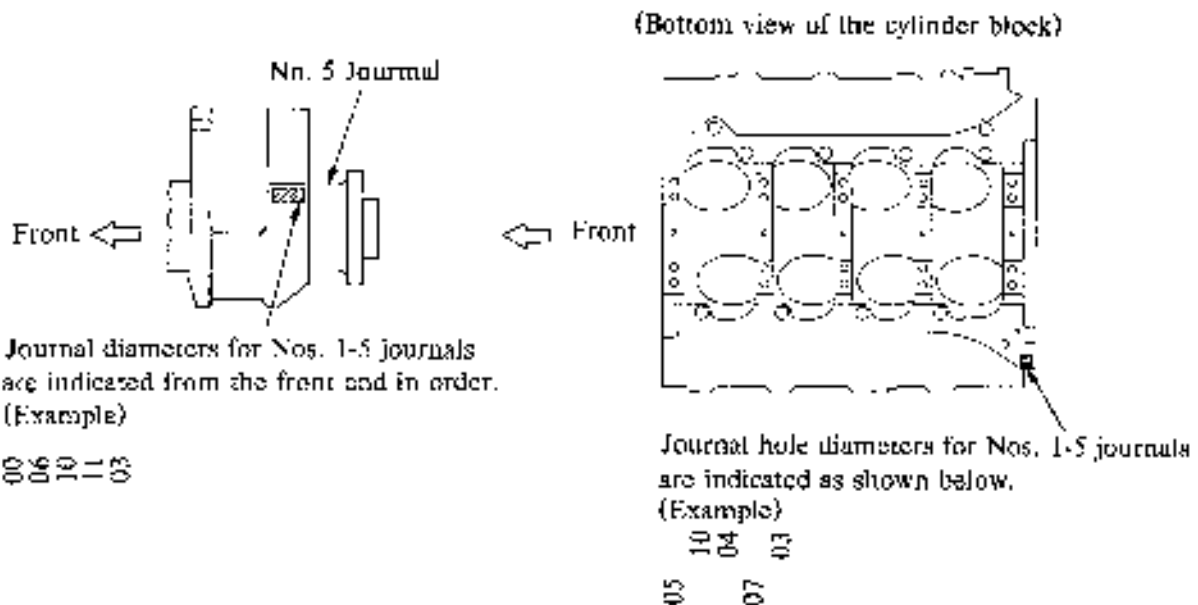

NOTE: Numbers of the crankshaft and pistons are shown on the right side.

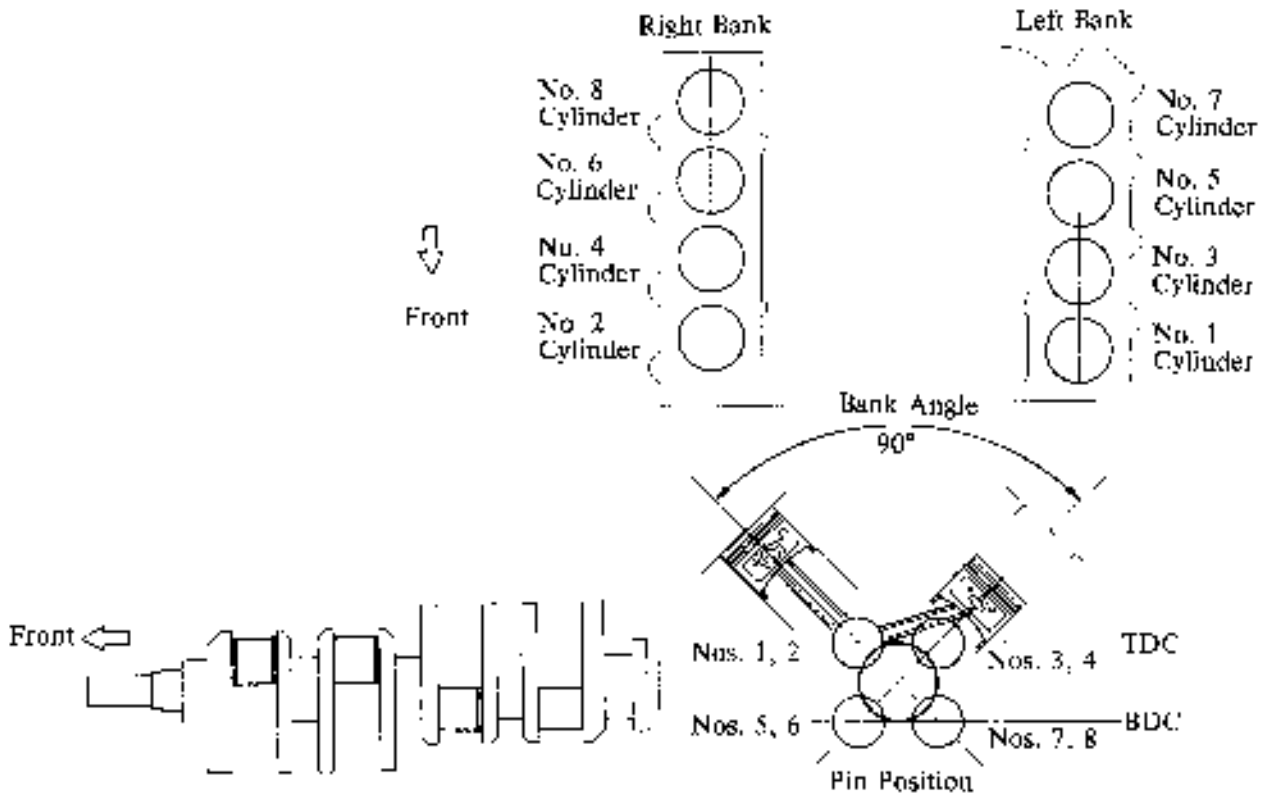

Crankshaft angles and engine strokes (intake, compression, combustion and exhaust) are shown in the table below. The firing order is 1-8-4-3-6-5-7-2.

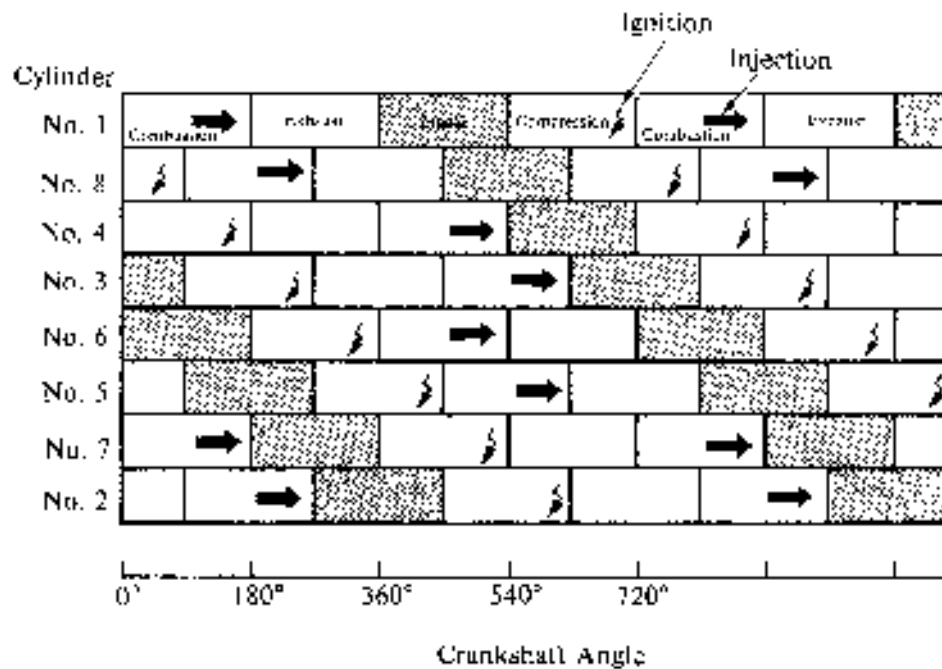

● VALVE MECHANISM

1. General

- Each cylinder has two intake valves and two exhaust valves.
- The valves are directly opened and closed by four camshafts.
- The intake camshafts are driven by a timing belt, while the exhaust camshafts are driven through gears on the intake camshafts.
- Use of outer shim type valve lifters makes it easy to adjust the valve clearance without removing the camshaft.

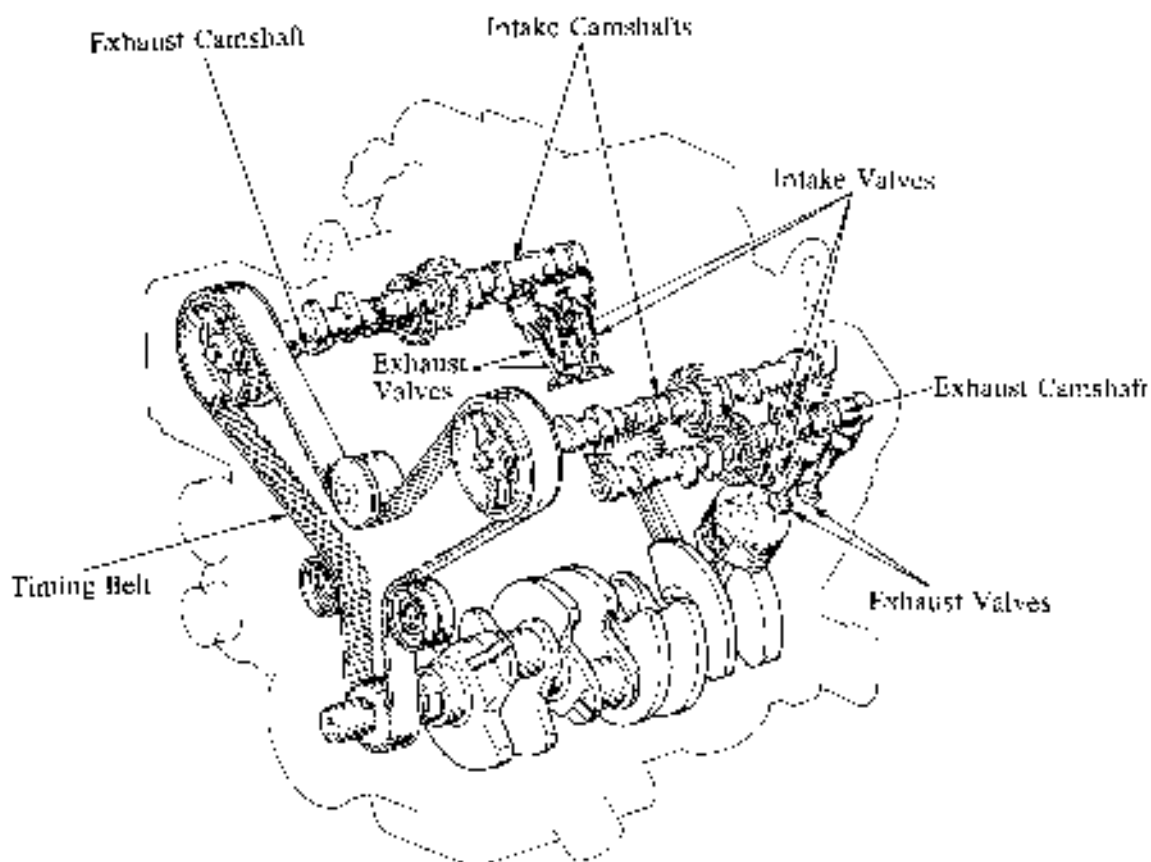

2. Camshafts

- The exhaust camshafts are driven by gears on the intake camshafts. The scissors gear mechanism has been used on the exhaust camshaft to control backlash and reduce gear noise.
- The camshaft journals and camshaft driven gear are lubricated by oil supplied to an oil passage in the center of the camshaft. Supply of oil from the cylinder heads to the camshafts is continuous, to prevent fluctuations in the oil pressure.
- The cast iron camshafts are used. The cam nose is chill treated.
- “T” type oil seals are used.

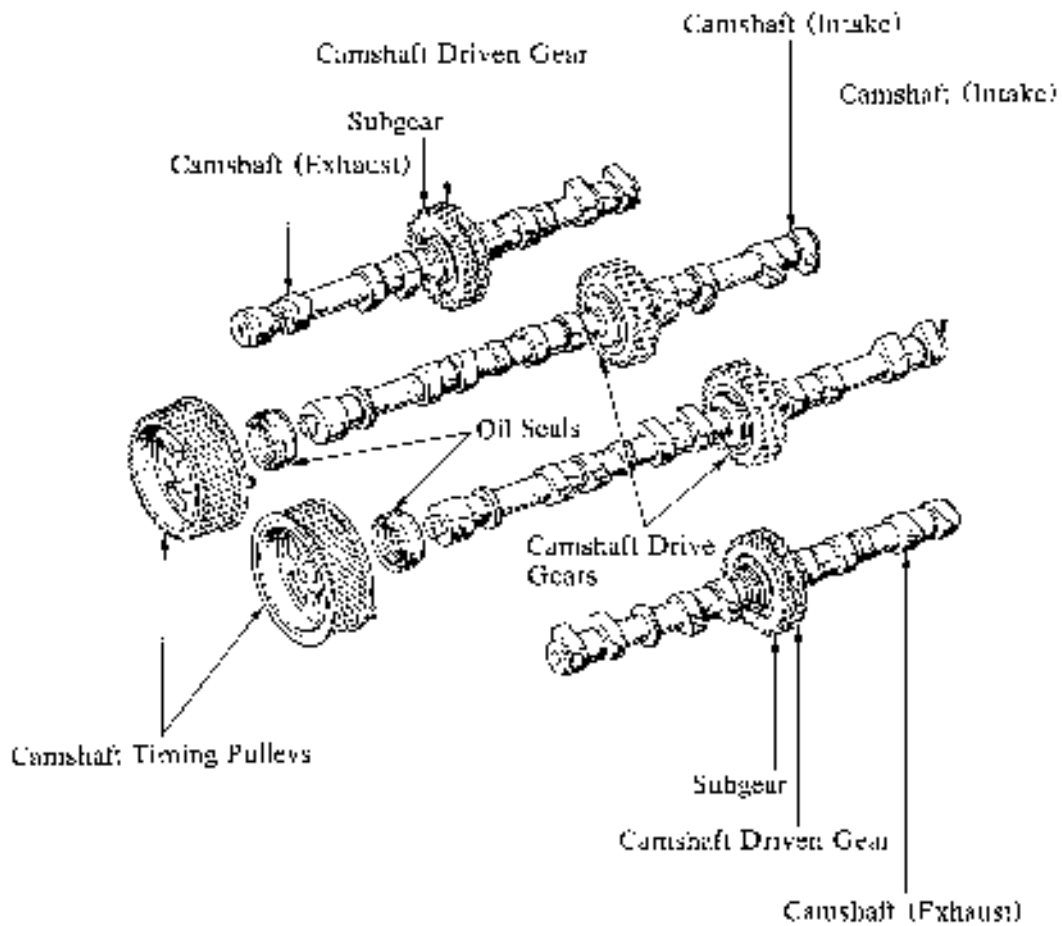

NOTICE

Be sure to follow the disassembly and reassembling procedures as directed in the Repair Manual to avoid possibility of damaging the cylinder head or camshaft timing gears (drive, driven and subgears).

—REFERENCE—

Scissors Gear Mechanism

To prevent the tooth surfaces of gears from seizing or being damaged when the gears are engaged, they are designed to have backlash. However, backlash generates noise when changes in torque occur. The scissors gear mechanism is one means of preventing this noise. The scissors gear mechanism uses a subgear with the same number of teeth as the drive gear and is attached to the gear on the driven side. Through the reaction force of the scissors spring, these two gears act to pinch the drive gear, reducing backlash to zero and eliminating gear noise.

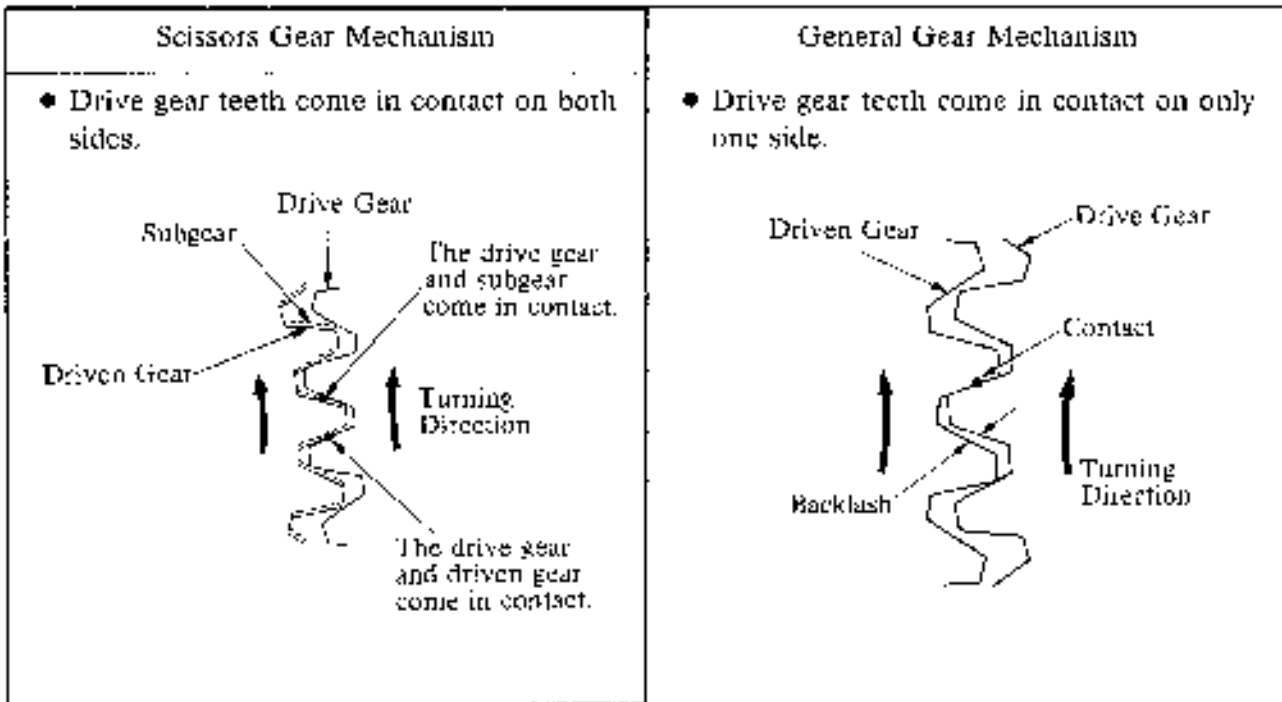
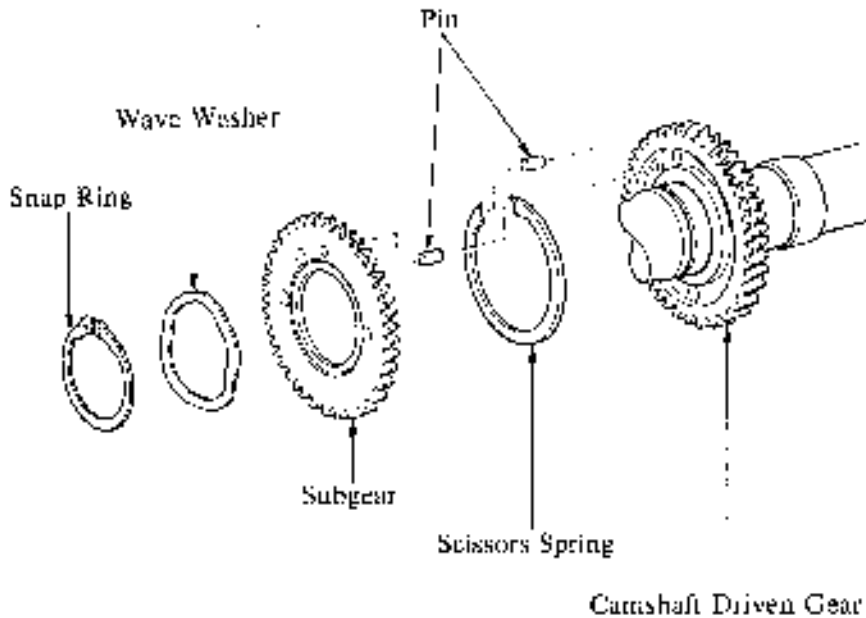

3. Valve Lifter and Valve Adjusting Shims

- Aluminum alloy valve lifters are used.
- The valve adjusting shims used are of the outer shim type and are located on top of the valve lifters. It is not necessary to remove the camshafts in order to replace the shims when the valve clearance is adjusted.

NOTE: (Method for replacing valve shims)

Push down the valve lifter using an SST (Special Service Tool) to make a gap between the camshaft and the valve lifter. Direct compressed air from an air gun to the service hole in the valve adjusting shim to float the shim and remove it using a magnetic finger. Be sure to direct the air gun carefully so that you do not blow the shim away.

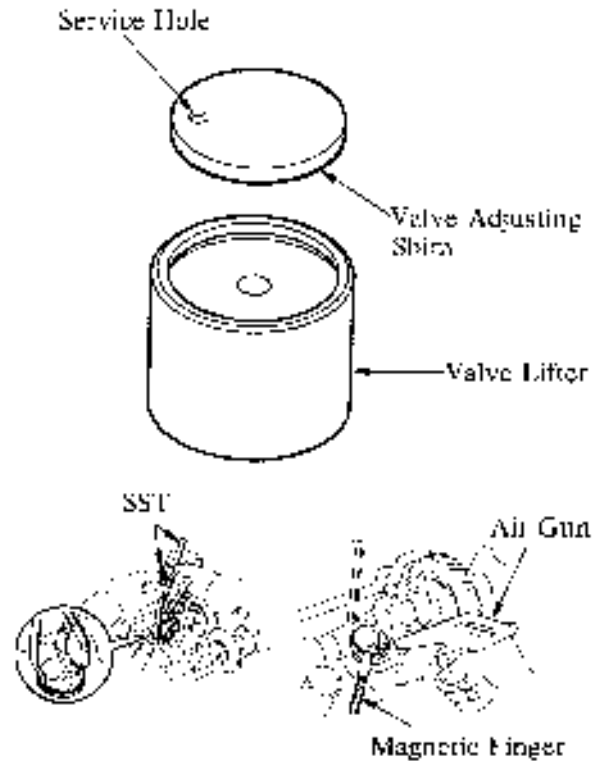

4. Timing Pulleys and Belt

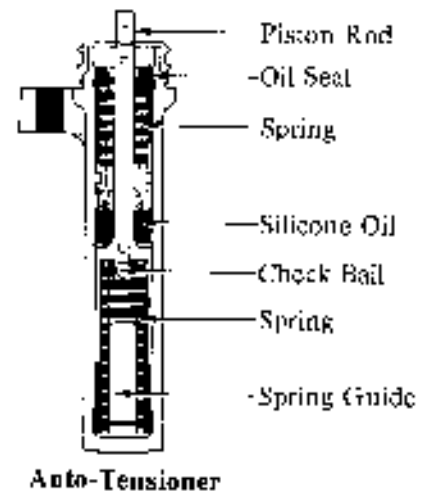
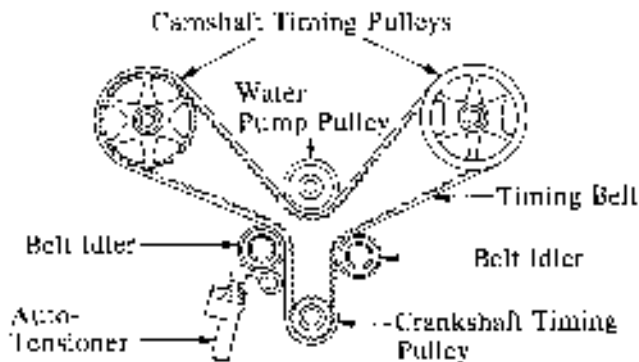

- An auto-tensioner is made up of a spring and oil damper, and maintains proper timing belt tension at all times. The auto-tensioner suppresses noise generated by the timing belt.
- The timing belt has high heat resistance and durability.
- The tooth profile of the timing belt is shown at the right. This design ensures a quiet operation and high-load transmission.

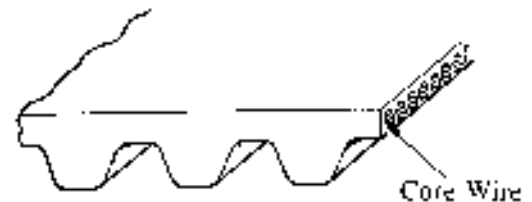

● LUBRICATION SYSTEM

1. General

- The lubrication is fully pressurized and all oil passes through an oil filter.
- The oil pump is a trochoid gear type and is directly driven by the crankshaft.

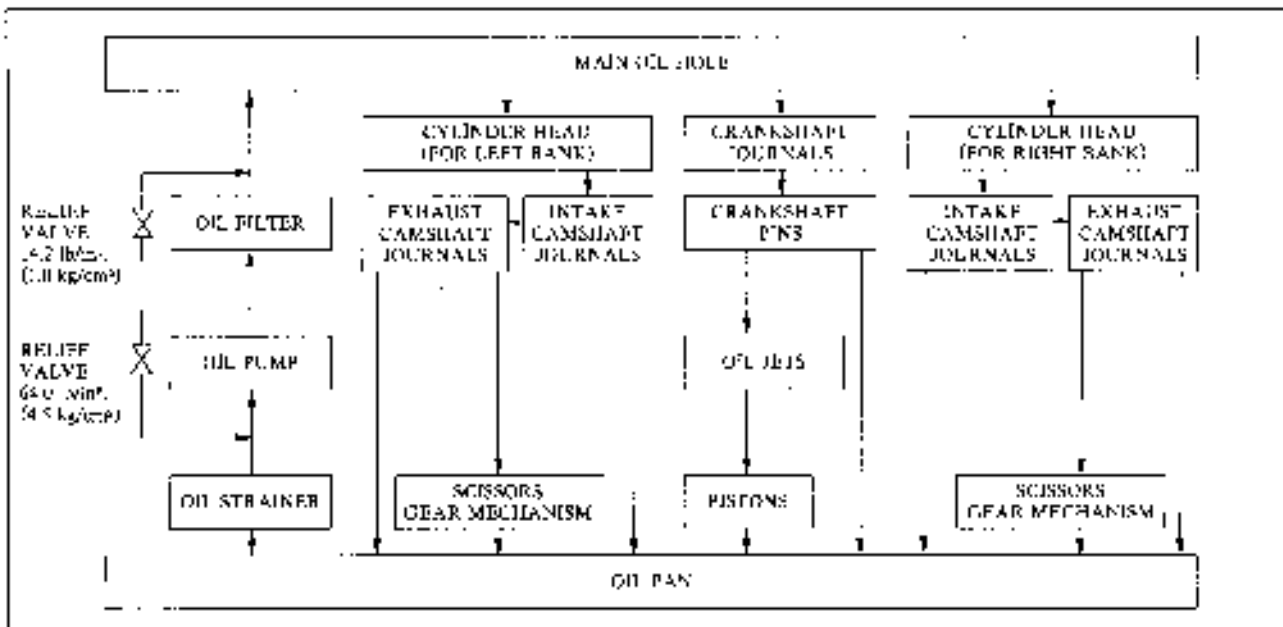
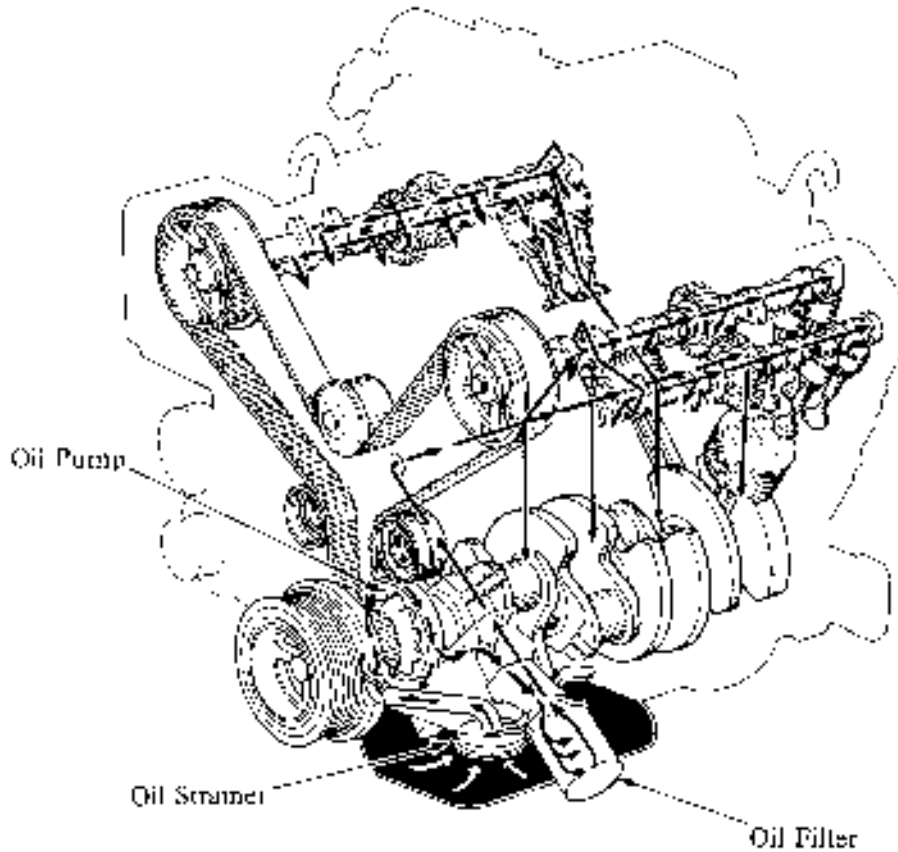

2. Oil Pan

- The oil pan is made up of two pieces. No. 1 oil pan is made of aluminum alloy and No. 2 oil pan is made of steel.
- The upper oil pan section is secured to the cylinder block and the torque converter housing, increasing rigidity.
- The baffle plate controls the oil flow between the two oil pans when the vehicle is turning or is running along rough roads, etc.

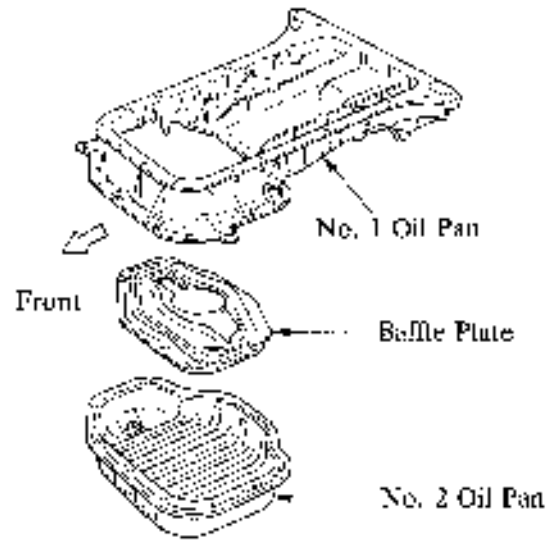

- An oil level sensor is provided in the oil pan for efficient servicing.

When the oil level falls below the specified level, the oil level sensor causes the low engine oil level warning light inside the combination meter to light up.

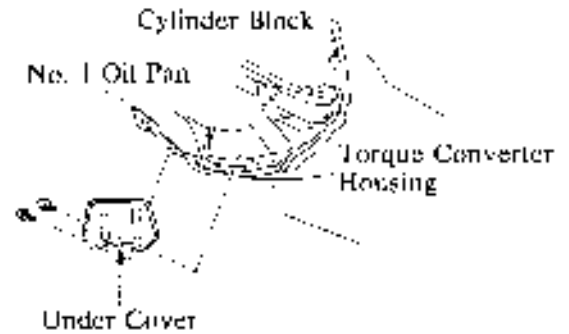

● COOLING SYSTEM

1. Cooling Circuit

- The cooling system is a pressurized, forced-circulation type.
- A thermostat, having a bypass valve, is located on the water pump inlet side of the cooling circuit. As the coolant temperature rises, the thermostat opens and the bypass valve closes, so the system maintains suitable temperature distribution in the cylinder head.
- A gauge coolant temperature sender, coolant temperature sensor, start injector time switch for the EFI (Electronic Fuel Injection) and BVSV (Bimetal Vacuum Switching Valve) for charcoal canister control are fitted to the front water joint.
- The rear water joint has bypass outlet ports for heating the throttle body, cooling the EGR valve and hot water for the heater.

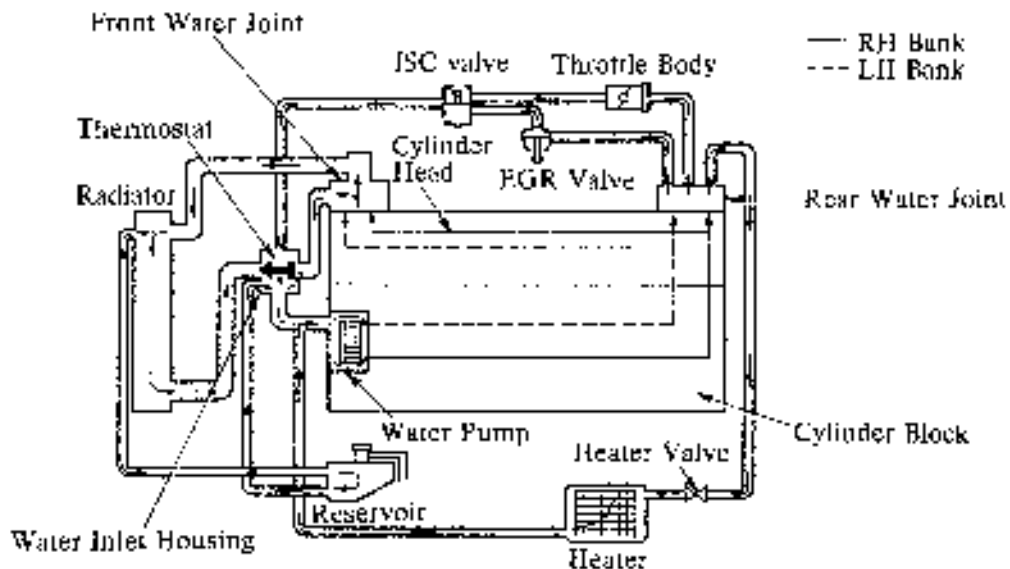
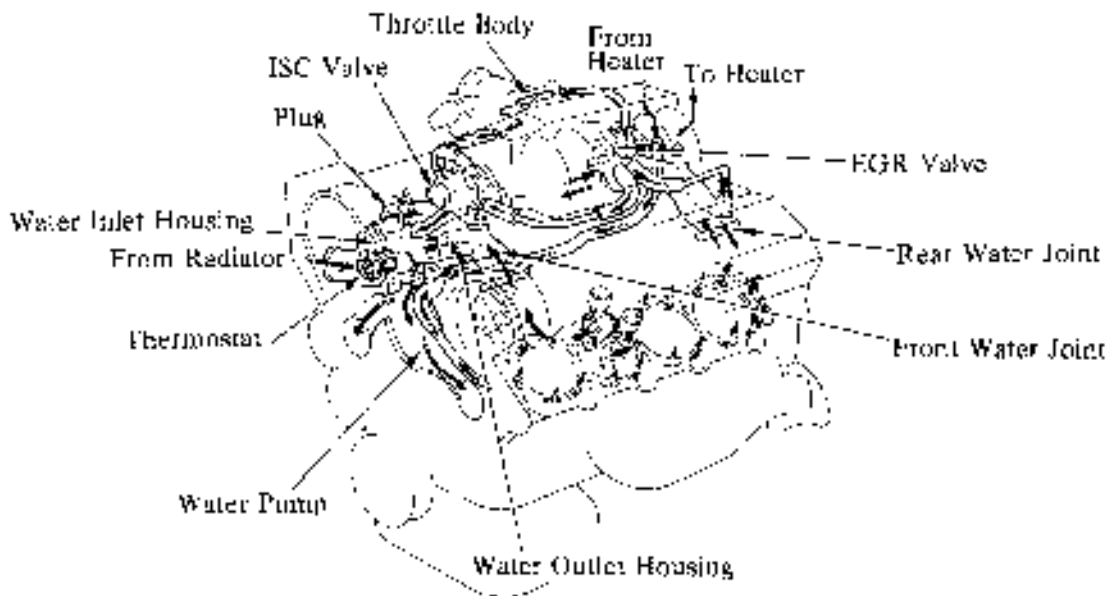

2. Water Pump

- The water pump has two volute chambers, and circulates coolant uniformly to the left and right banks of the cylinder block.
- The water pump is driven by the back of the timing belt.
- The rotor is made of resin.

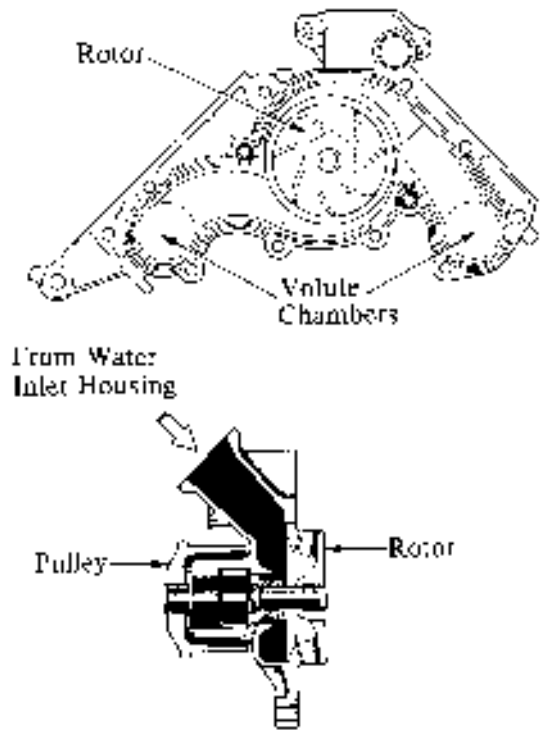

3. Reservoir Tank

- A pressurized valve is fitted to the reservoir.
- A coolant level sensor is provided for efficient servicing.

When the coolant level falls below the specified level, the coolant level sensor causes the low engine coolant level warning light inside the combination meter to light up.

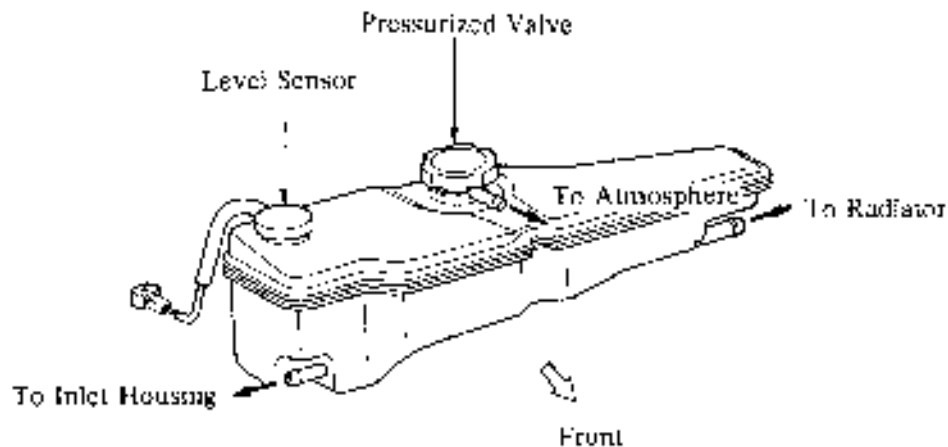

CAUTIONS

1. Never remove the cap while it is hot because the reservoir is also pressurized.
2. Engine coolant is replenished from the reservoir. To do so, first loosen the plug at the top of the inlet housing (shown on Page 98) to bleed air out of the cooling system. Be sure that the system is filled with coolant completely.

4. Coupling Fan

- A three stage temperature-controlled auto coupling fan is used.

The speed of the coupling fan changes in three stages based on the temperature of the air passing through the radiator.

This keeps the fan speed low when the temperature is low, improving warm-up performance and reducing fan noise.

The fan speed is high when the engine temperature is high, improving the cooling performance.

Since part of the oil in the coupling fan is stored in the back storage chamber, the amount of oil in the operating chamber decreases at engine start. Oil resistance and the fan speed are reduced as a result immediately after engine start.

The oil stored in the back storage chamber gradually flows into the operating chamber as the coupling fan keeps revolving. It eventually flows entirely into the operating chamber.

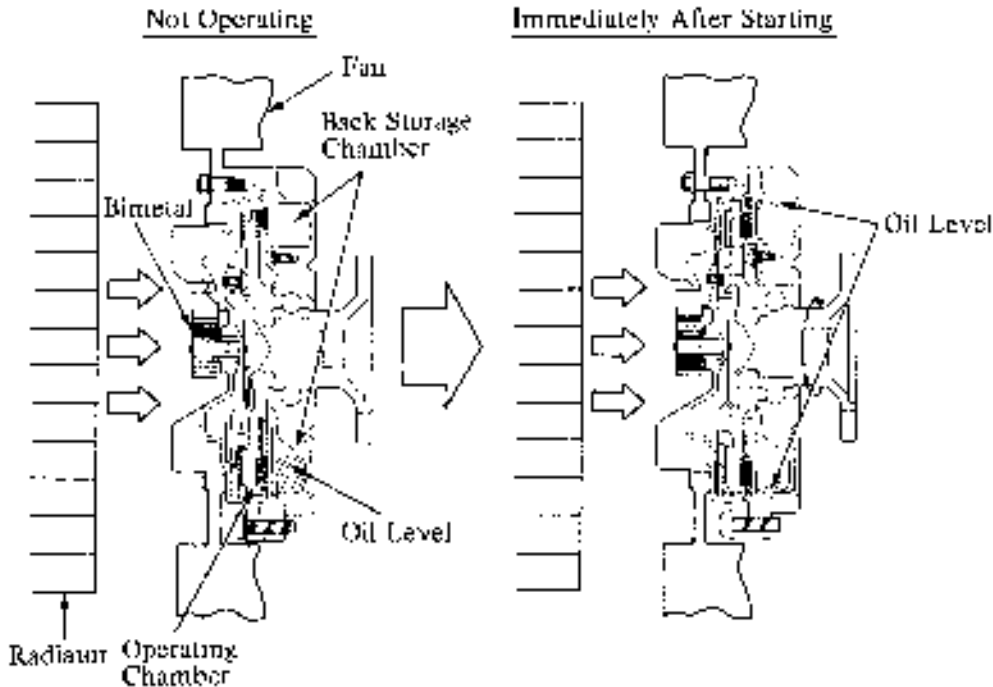
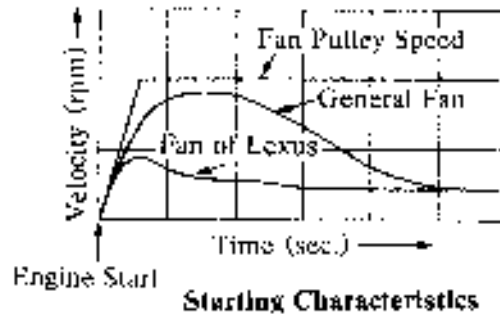
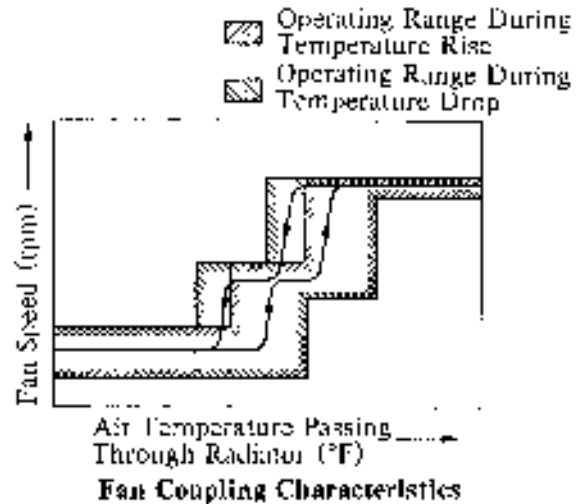

● INTAKE AND EXHAUST SYSTEM

1. Air Cleaner

The air cleaner case and cap are made of resin and have a large filtering capacity for the large engine displacement. The air cleaner element is a low air resistance type and allows the air to pass through it very smoothly.

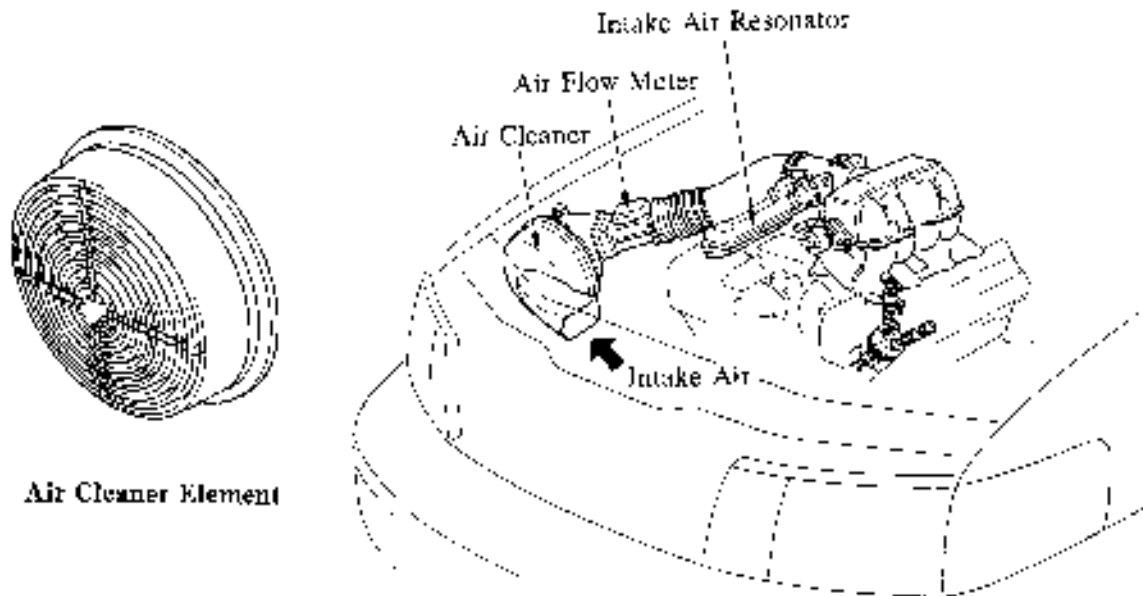

2. Intake Air Resonator

- A resonator is used to reduce the intake air noise.
- The resonator is made of resin. The air passage and resonator chamber are formed separately. The resonator chamber is of the dual mode type and is separated by a partition.

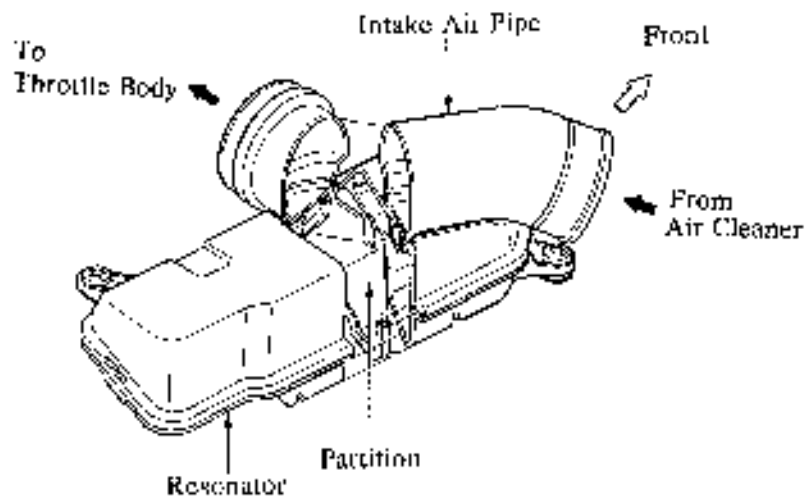

3. Intake Air Chamber

- The EGR and ISC (Idle Speed Control) passages are attached to the intake air chamber.
- The start injector is located at the center of the intake air chamber so that fuel is distributed evenly to all cylinders.

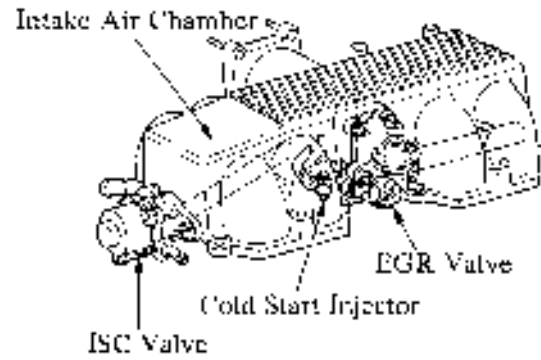

4. Intake Manifold

- Ports are crossed to increase the port length and inertia effects of the intake air.

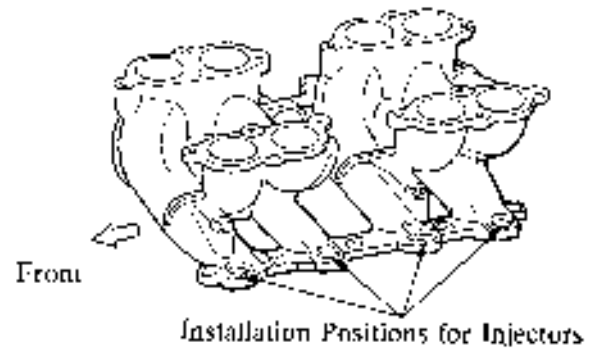

5. Exhaust Manifold

- Both exhaust manifolds are made of stainless steel.
- The exhaust manifolds are covered with heat insulators to protect the surrounding parts from exhaust heat.

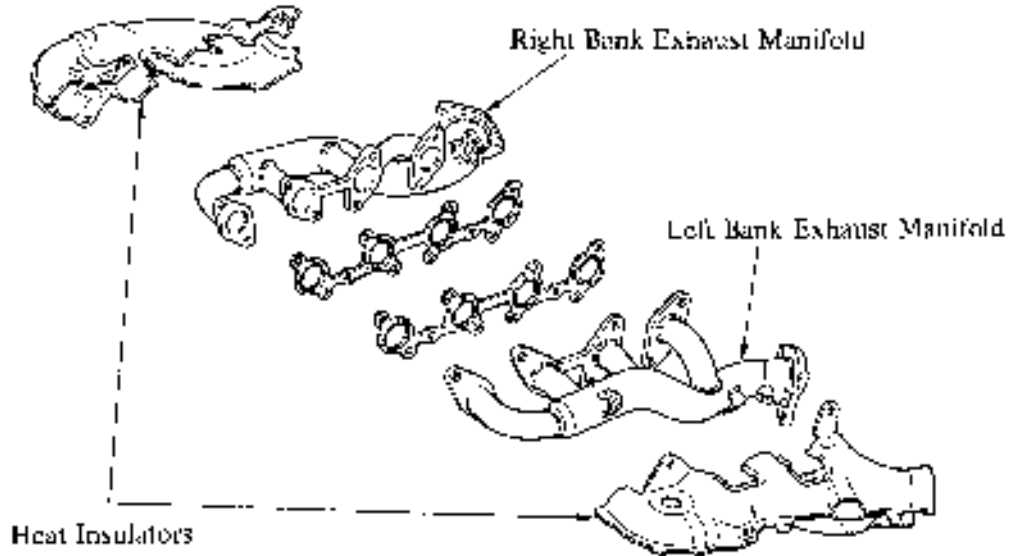

6. Exhaust Pipe

- The stainless steel exhaust pipe consists of three sections; the front, center and tail. The center section is single pipe while the front and tail are dual pipes to reduce exhaust resistance.
- The catalyst converters (start and main) are of the monolithic type three-way catalysts.
- The main catalyst converter is newly developed and has a high performance.
- Large mufflers (main and sub) effectively reduce noise and exhaust pressure from the large capacity engine.

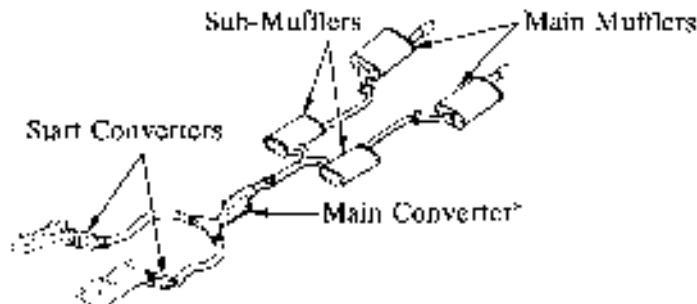

* Applicable only to the California specification vehicles. Refer to page 161 for detail.

● SERPENTINE BELT DRIVE SYSTEM

- The serpentine belt drive system drives accessory components with a single V-ribbed belt. It reduces the overall engine length, weight and number of engine parts.
- An automatic tensioner eliminates the need for tension adjustment.

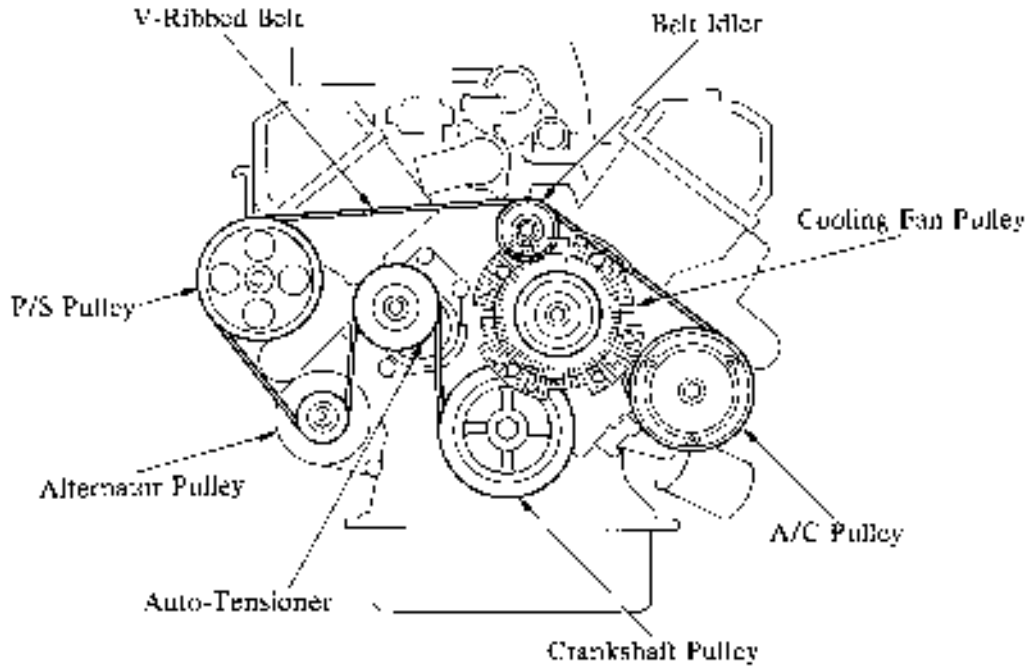

- The arm is pushed by the tension spring in a clockwise rotation direction always centering around “Z”.

The pulley’s center of rotation is bolted to the arm.

For this reason, when the belt stretches with time, the pulley center of rotation rotates to the right in an arc around “Z” with the arm. Thus the belt tension is always maintained appropriately.

NOTICE

- Check the indicator mark. If it is outside the operation range, replace the belt.
- When a new belt is installed, the graduations must be in the area indicated by “A” in the picture.

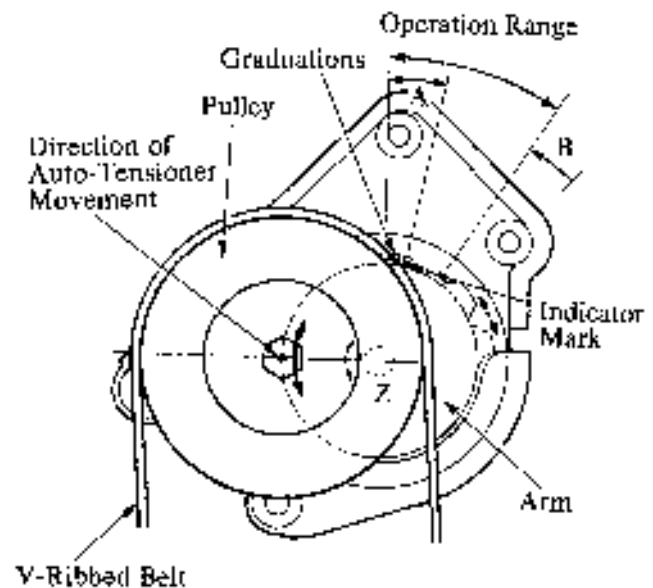

Auto-Tensioner

● ENGINE MOUNTING

1. General

- Liquid-filled compound engine mounts are fitted on both sides of the engine to reduce vibration and noise at all speeds.
- The aluminum engine mounting brackets reduce vibration and noise and minimize the total engine weight.

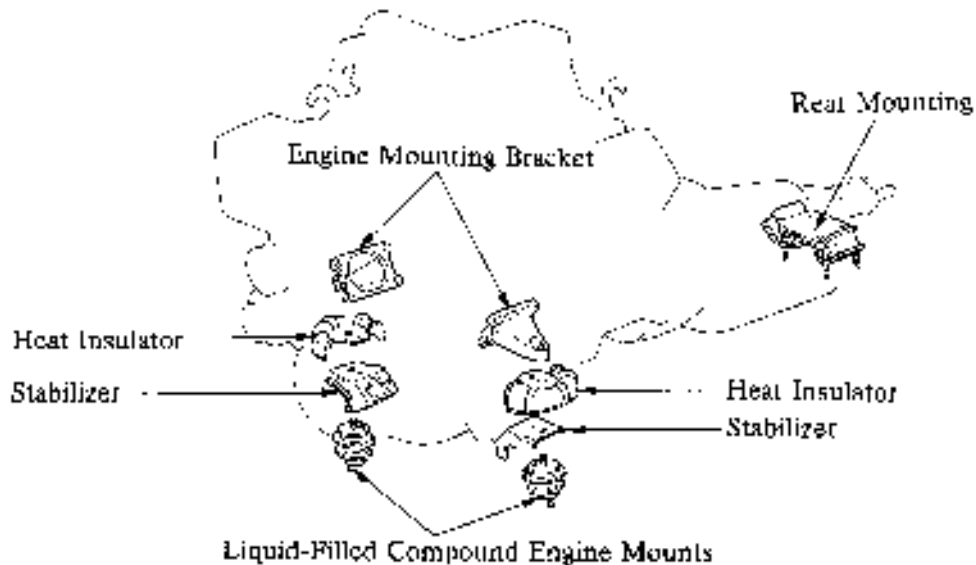

2. Liquid-Filled Compound Engine Mount

The engine mount combines rubber with liquid filled chambers.

The fluid flows between upper and lower chambers through an orifice.

In addition to vibrations being absorbed by the rubber mounting, low frequency vibration is absorbed by the fluid flowing through the orifice. Also, by decreasing the elasticity of the rubber, the dynamic spring constant has been reduced, providing greater noise reduction in the case of high frequency vibrations.

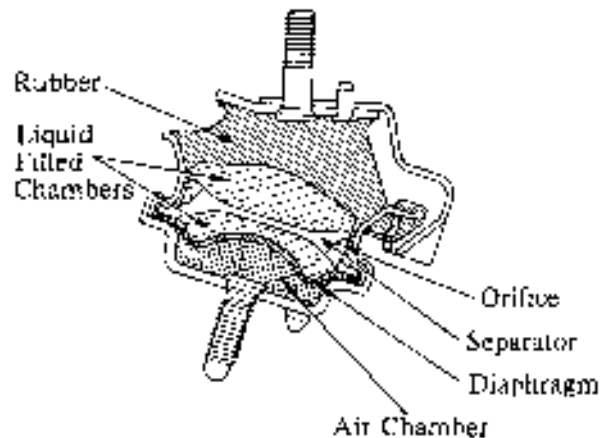

● **STARTING SYSTEM**

1. Starter

- The starter output is 2.0 KW and is located inside the V-bank of the cylinder block.

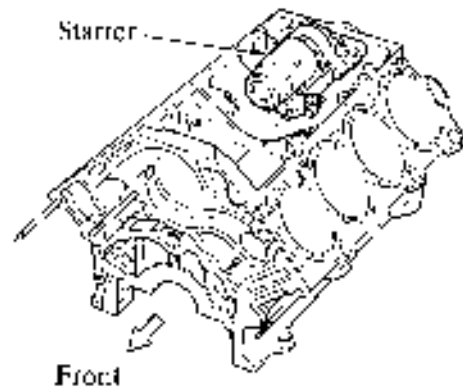
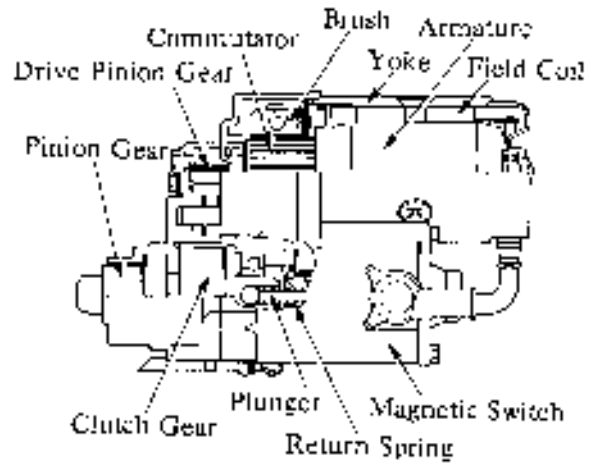

● **CHARGING SYSTEM**

1. Alternator

- The IC regulated alternator has a large output of 1200 watts to produce enough electricity for the electric load.
- The alternator is fitted directly (without brackets) to the cylinder block.

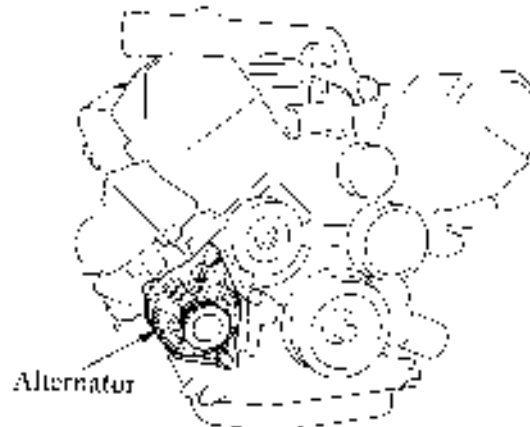
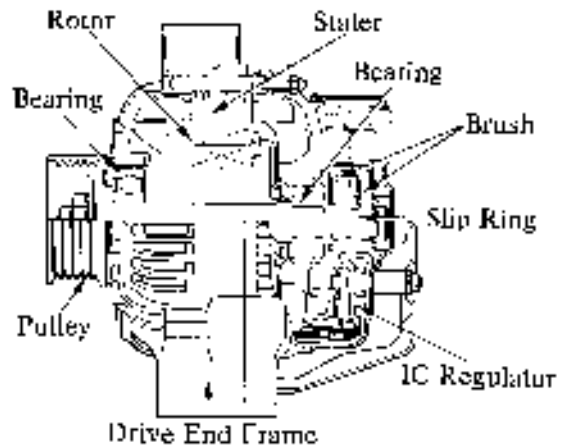

● ENGINE MOUNTING

1. General

Engine control system uses an ECU (Electronic Control Unit) with a built-in microprocessor. Stored inside the ECU is the data for fuel injection duration, ignition timing and idling speed, etc. which are matched with the various engine conditions as well as programs for calculation. The ECU utilizes these data and signals from the various sensors in the vehicle and makes calculations with the stored programs to determine fuel injection duration, ignition timing and idling speed, etc., and outputs control signals to the respective actuators which control operation.

The engine ECU and transmission ECU are integrated into one and the ECU is called the engine and transmission ECU. The engine control system for the 1UZ-FE engine has the following functions:

EFI (Electronic Fuel Injection)

The ECU determines the fuel injection duration according to intake air volume, engine speed, coolant temperature and other signals and sends control signals to the fuel injectors. Also, this fuel injection duration is the basis for deciding the fuel injection timing. The fuel injection system in the 1UZ-FE engine is a four group injection system which injects fuel simultaneously into two cylinders once every two engine revolutions.

ESA (Electronic Spark Advance)

The ECU determines the amount of ignition advance over the initial set timing of the distributor by the intake air volume, engine speed, coolant temperature and other signal and sends control signals to the igniters. Also, based on signals from the knock sensors, the ECU controls the ignition timing at the optimum in accordance with the gasoline's octane value.

ISC (Idle Speed Control)

By means of engine speed signals and coolant temperature signals, the ECU sends control signals to the ISC valve so that the actual idling speed becomes the same as the target idling speed stored in the ECU. Also, while the engine is warming up, the ECU, based on coolant temperature signals, sends controls signals to the ISC valve to control engine speed to fast idle.

EGR (Exhaust Gas Recirculation) CUT CONTROL

The ECU sends signals to the EGR VSV to cut the EGR based on coolant temperature, engine speed, neutral start switch or intake air volume signals. This system maintains drivability at low coolant temperature, under light or heavy load conditions, or at high engine speed, etc.

FUEL PRESSURE CONTROL

The ECU sends signals to the pressure regulator VSV based on coolant temperature, intake air temperature, vehicle speed and engine start signals, and increases the fuel pressure. This system maintains restartability and idling stability when the engine is hot.

FUEL PUMP SPEED CONTROL

The ECU, based on fuel injection duration, sends control signals to the fuel pump control relay to control the fuel pump speed. That is, when the engine requires a large volume of fuel, the fuel pump turns at high speeds and when only a small volume of fuel is required, the pump turns at low speeds.

OXYGEN SENSOR HEATER CONTROL

Based on the intake air volume, engine start and coolant temperature signals, the ECU sends control signals to the oxygen sensor heater. This system maintains the oxygen sensor at the appropriate temperature in order to improve the detecting accuracy of oxygen concentration in the exhaust gas.

AIR CONDITIONER CONTROL

Based on the air conditioner switch signal from the air conditioner ECU, the ECU sends control signals to the magnetic clutch of the air conditioner compressor. This system, the magnetic clutch operation, is delayed for a predetermined period after the air conditioner switch is turned on.

DIAGNOSIS

The ECU is constantly monitoring signals from each sensor. If a malfunction occurs with the signals, the CHECK ENGINE lamp on the combination meter lights up and informs the driver of the malfunction.

The content of the malfunction is stored in code in the ECU and when the TE₁ and E₁ terminals in the check connector or TDCL are connected, the ECU outputs the trouble code by flashing the CHECK ENGINE lamp.

FAIL-SAFE

If the ECU judges from the signals from each sensor that there is a malfunction, it continues the engine operation using its own data or it stops the engine.

2. Construction

The engine control system can be broadly divided into three groups: the ECU, the sensor and the actuators.

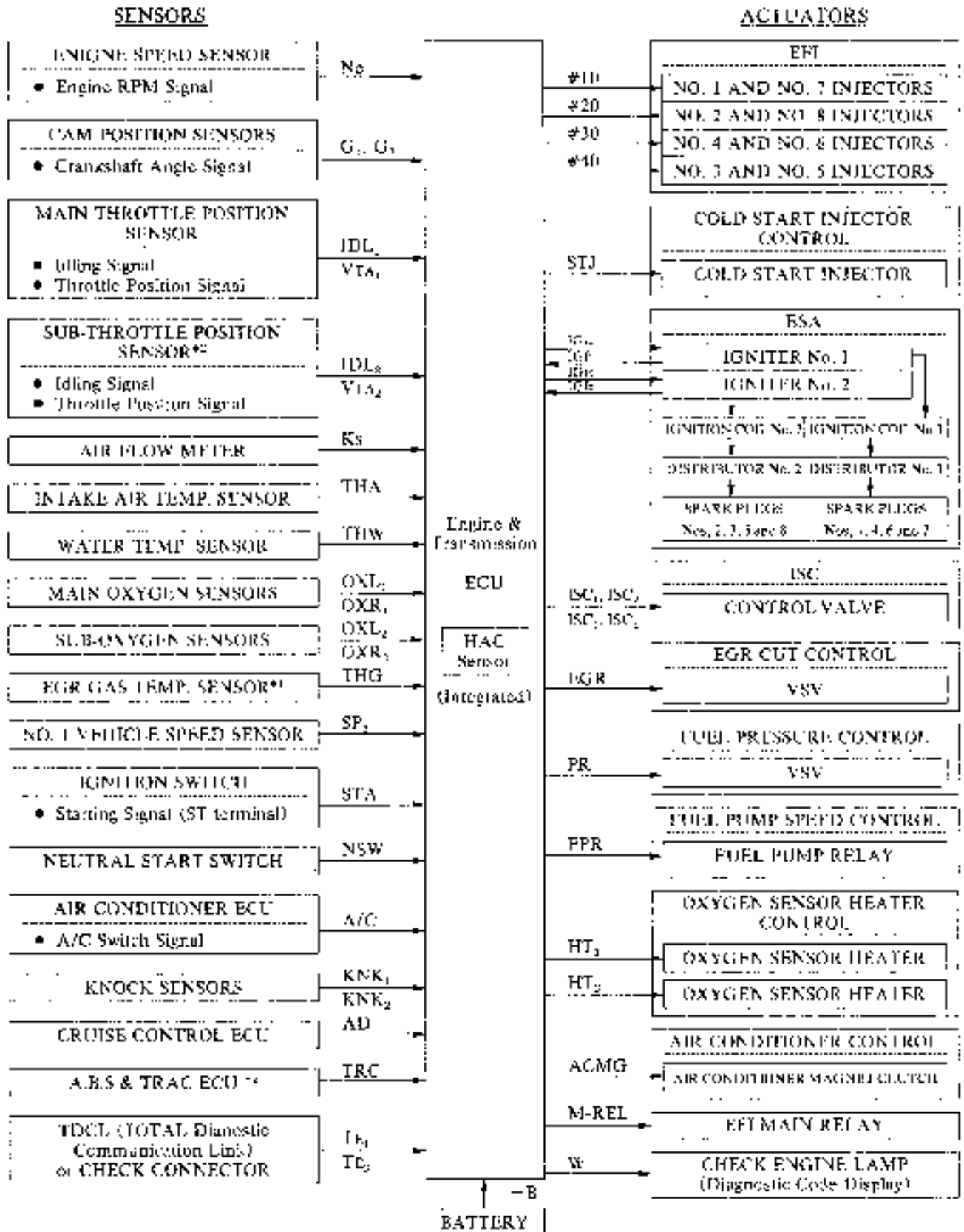

¹ Applicable only to California specification vehicles.

*² Applicable only to vehicles equipped with the optional TRAC (Traction Control) system

3. Summary of Engine Control System

The following list summarizes each system and control composing engine control system of the 1UZ-FE engine and types of the related sensors, ECU and others.

		SENSORS															ECU													
		KS	NS	G	EDW	THA	IDL1	VIA	IDL2	VIA2	SA	IGFWS	SP	OX1	OX2	OX3	THO	KNK	SNK	MSW	IP	TC	RAM	J	TRC	AD	ACC	Start Injery Time Switch		
LPI	Starting Injection Control																													
	Basic Injection Position																													
	Injection Corrections																													
	After-Start Enrichment																													
	Warm-Up Enrichment																													
	Acceleration Enrichment (Hot & Warm-Up)																													
	Power Enrichment																													
	Air-Fuel Ratio Feedback Correction																													
	Voltage Correction																													
	Fuel Cut-Off																													
MSA	Cold Start Injection Control																													
	Starting Ignition Control																													
	Basic Ignition Advance Angle Control																													
	Corrective Ignition Advance Angle Control																													
	Warm-Up Correction																													
	EGR Correction																													
	Knocking Correction																													
	Torque Control Correction																													
	Maximum and Minimum Advance Angle Control																													
	Igniter Control																													
ECU	Initial Set-Up																													
	After Start Control																													
	Warm-Up Control																													
	Feedback Control																													
	Load Speed Change Estimate Control																													
	EGR Cut-Off Control																													
	Fuel Pump Speed Control																													
	Fuel Pressure Control																													
	Oxygen Sensor Heater Control																													
	Air Conditioner Compressor Duty Control																													

*1: Applicable only to California specification vehicles.

*2: Applicable only to vehicles equipped with the optional TRAC (Traction Control) system

4. Engine Control System Diagram

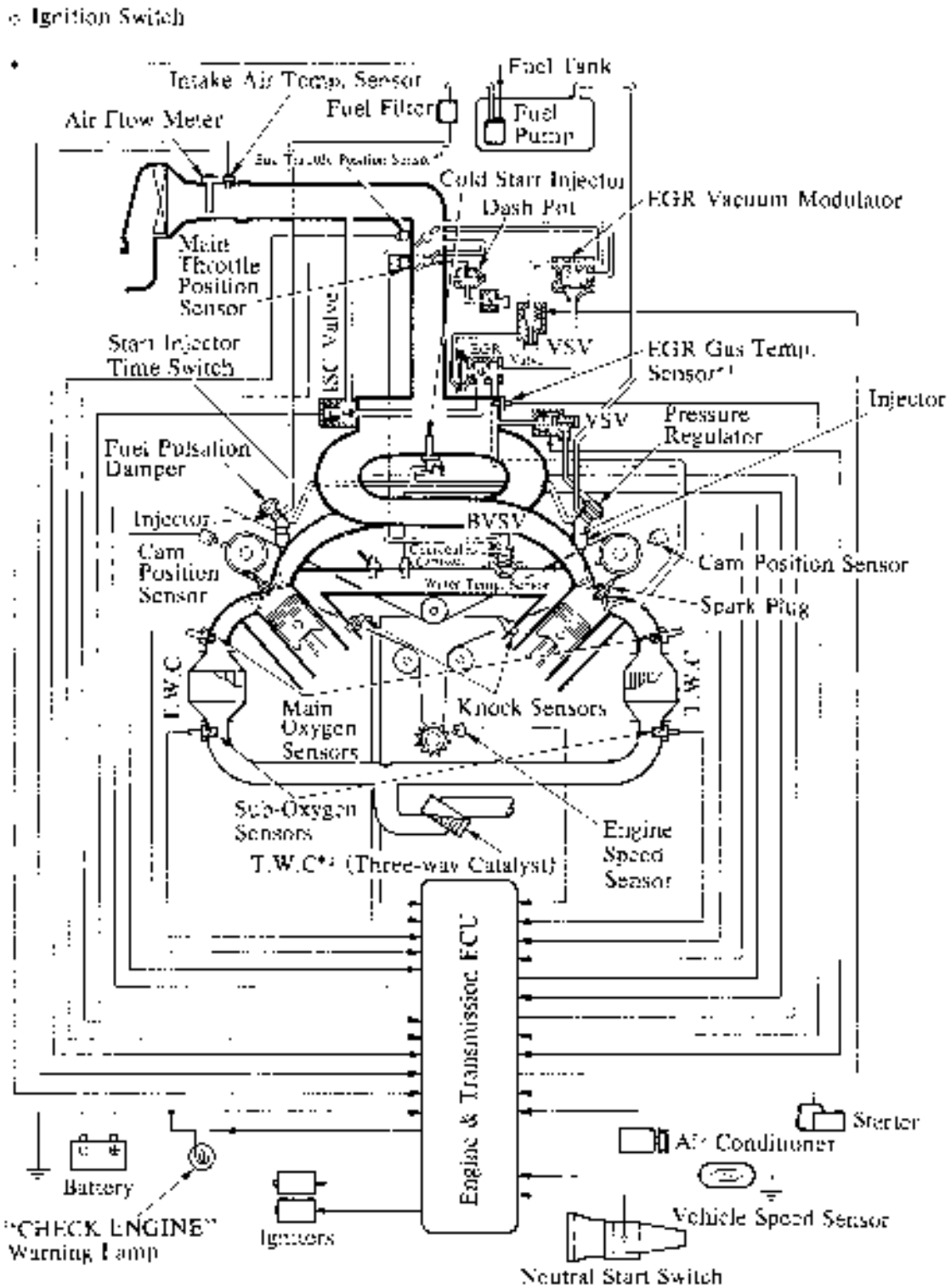

5. Arrangement of Engine Control System Components

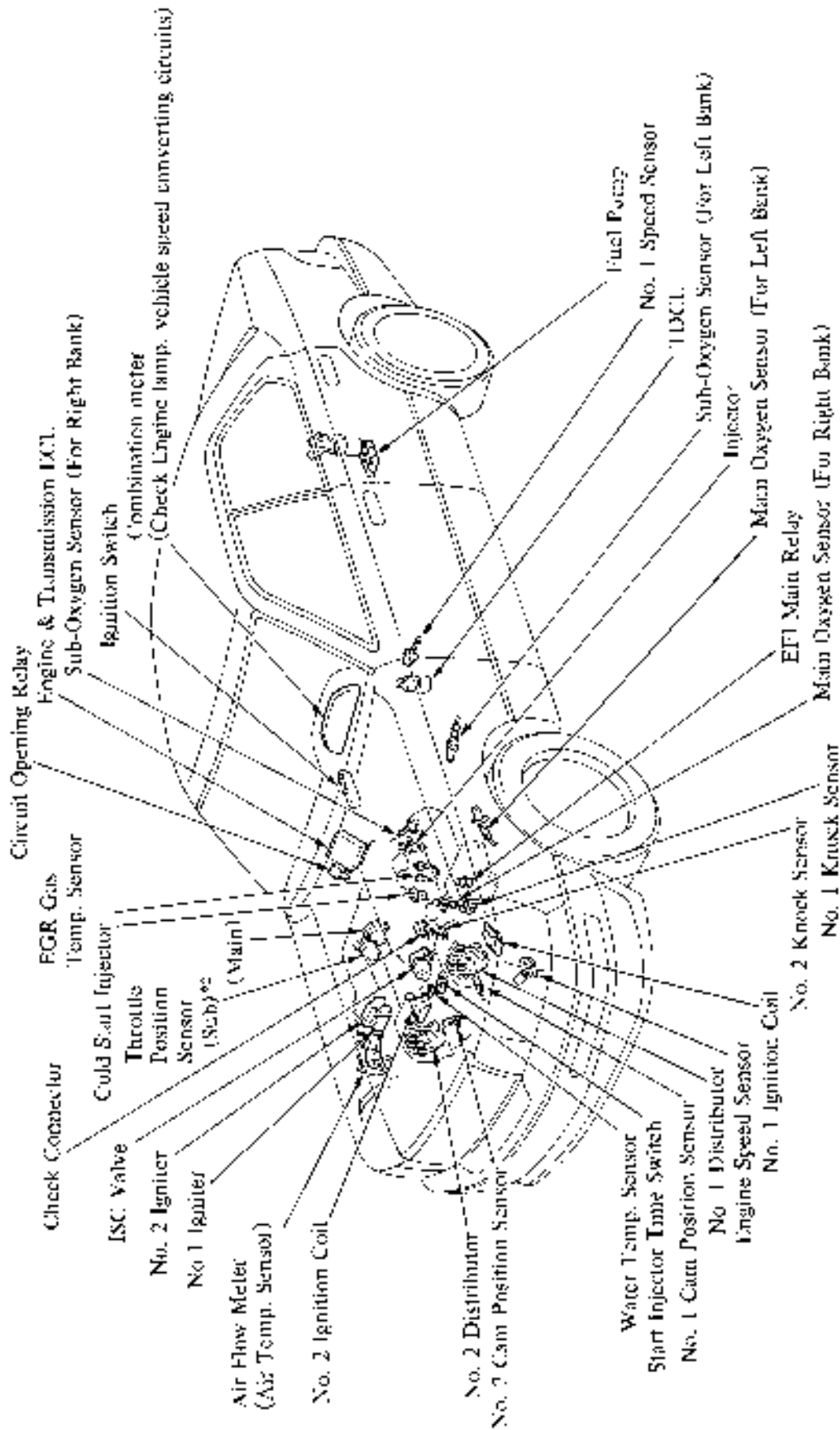

*1 Applicable only to the California specification vehicles
 *2 Applicable only to the vehicles equipped with the optional TRAC (Traction Control System)

6. EFI (Electronic Fuel Injection)

The EFI system consists of the following three major systems:

- 1) Fuel System
- 2) Air Induction System
- 3) Electronic Control System

Fuel System

1) General

Fuel is pumped under pressure by the electric fuel pump from the fuel tank, through the fuel filter, to the injectors and the cold start injector.

The pressure regulator controls the amount of fuel being returned to the fuel tank through the return pipe, thus adjusting the pressure of fuel to the injectors.

The pulsation damper absorbs the minute fluctuations in fuel pressure due to injection of fuel.

The injectors inject fuel into the intake port in accordance with injection duration signals from the ECU.

The cold start injector injects fuel into the air intake chamber when the coolant temperature is low, improving startability in cold weather.

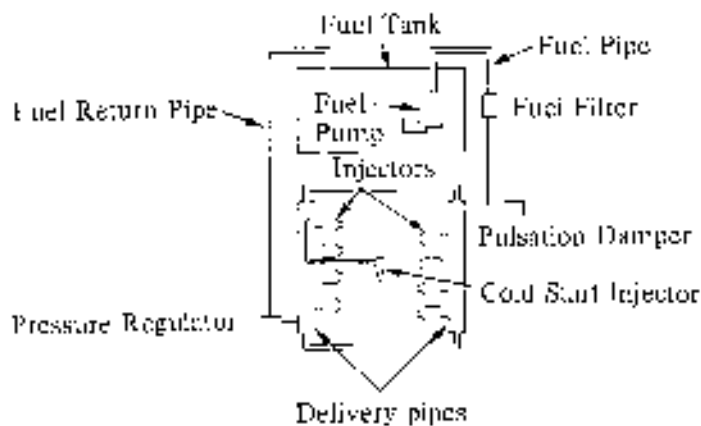
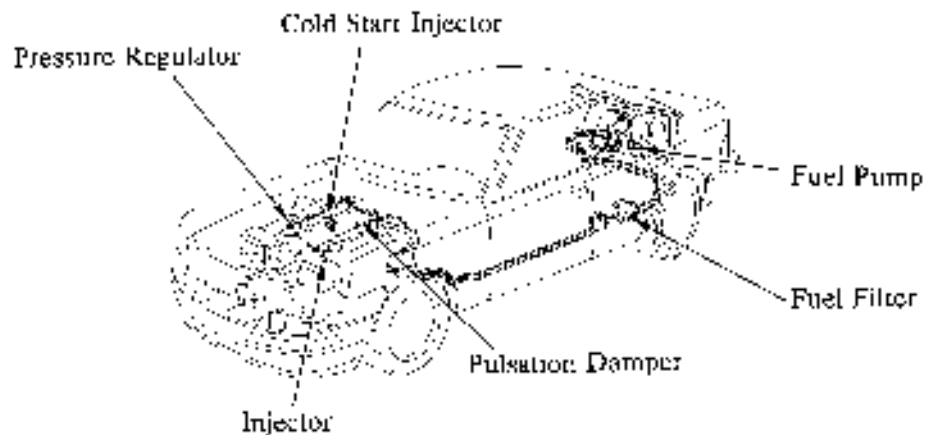

2) Fuel Pump

An in-tank type fuel pump is provided inside the fuel tank.

A turbine pump, with little discharge pulsation of the fuel in the pump, is used.

This pump consists of the motor portion and the pump portion, with a check valve, relief valve and filter also incorporated into the unit.

a. Turbine Pump

The turbine pump consists of the impeller, which is driven by the motor, and the casing and pump cover, which compose the pump unit. When the motor turns, the impeller turn along with it.

Blades on the outer circumference of the impeller pull fuel from the inlet port to the outlet port.

Fuel discharged from the outlet port passes through the motor portion and is discharged from the pump through the check valve.

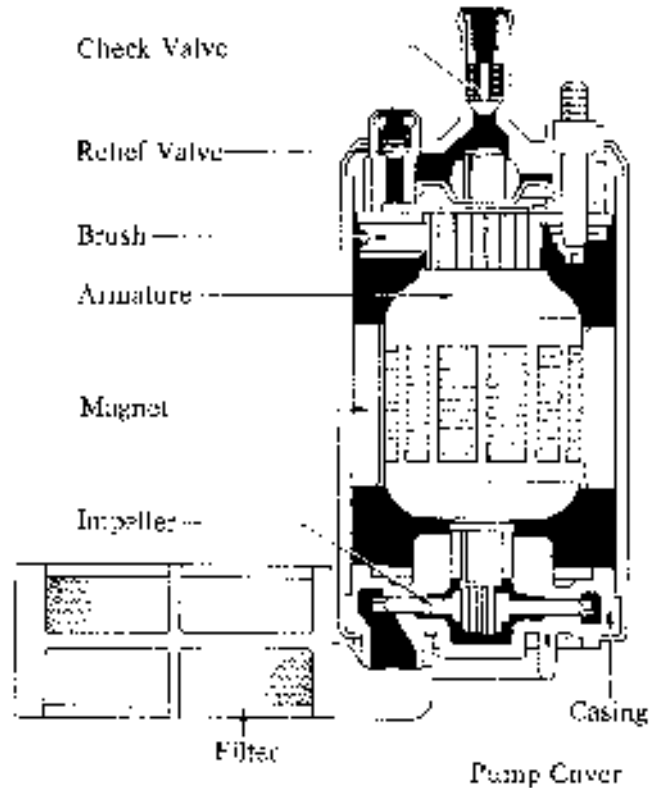

b. Relief Valve

The relief valve open when the discharge side pressure reaches $71.1 \rightarrow 92.3 \text{ lb/in.}^2$ ($5.0 \rightarrow 6.5 \text{ kg/cm}^2$) and the high pressure fuel is returned directly to the fuel tank.

The relief valve prevents the fuel pressure from rising beyond that level.

c. Residual Pressure Check Valve

The check valve closes when the fuel pumps stops.

The residual pressure check valve and pressure regulator both work to maintain residual pressure in the fuel line when the engine is stopped, thus easing restartability.

If there were no residual pressure, vapor lock could occur easily at high temperatures, making it difficult to restart the engine.

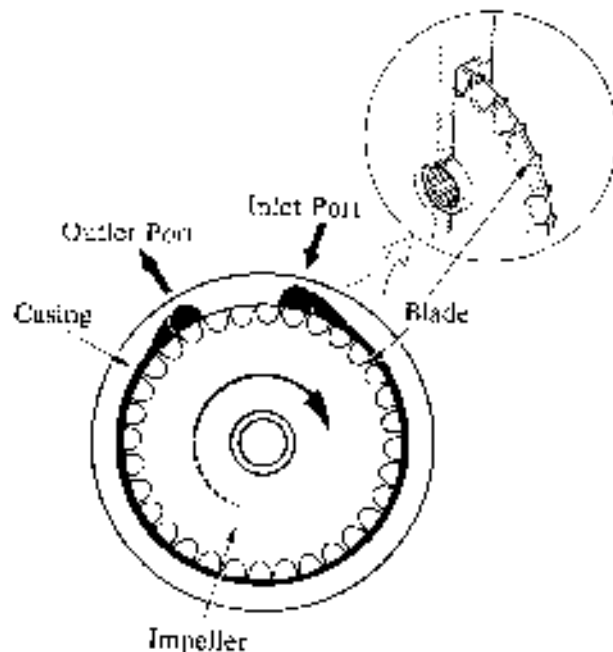

- The 1UZ-FE engine has a fuel pump speed control (ECU controlled) system which regulates the amount of electricity flowing to the fuel pump and thus the amount of fuel delivery according to the engine load. See page 149 for detail.

3) Fuel Filter

The fuel filter filters out dirt and other foreign particles from the fuel. It is installed at the high pressure side of the fuel pump.

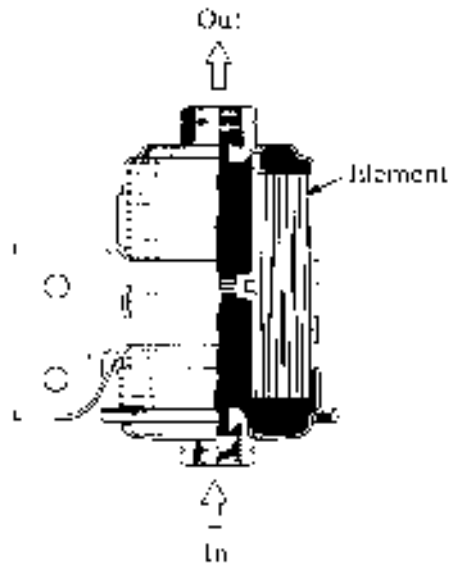

4) Pulsation Damper

Fuel pressure is maintained at 41 lb/in.² (2.9 kg/cm²) in relation to the manifold vacuum, by the pressure regulator. However, there is a slight variation in line pressure due to injection. The pulsation damper acts to absorb this variation by means of a diaphragm.

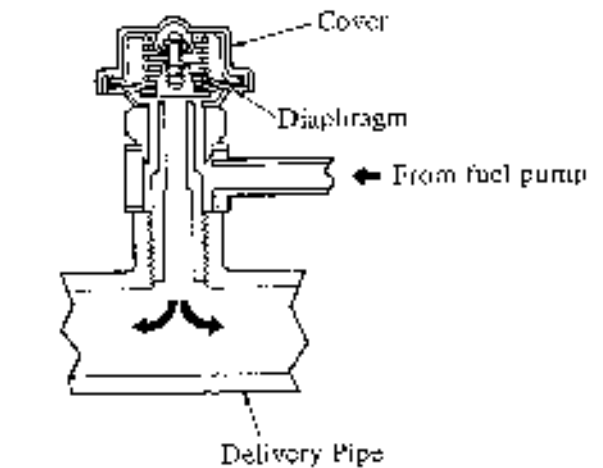

Low Pressure



High Pressure

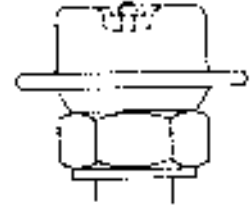

5) Pressure Regulator

a. Function

The pressure regulator regulates the fuel pressure to the injectors. Fuel injection quantity is controlled by the duration of the signal applied to the injectors, so that a constant pressure must be maintained to the injectors. However, as fuel is injected into the intake port and manifold vacuum varies, the fuel injection quantity will vary slightly even if the injection signal and fuel pressure are constant. Therefore, to acquire an accurate injection quantity, the sum of the fuel pressure A and intake manifold vacuum B must be maintained at 41 lb/in.² (2.9 kg/cm²).

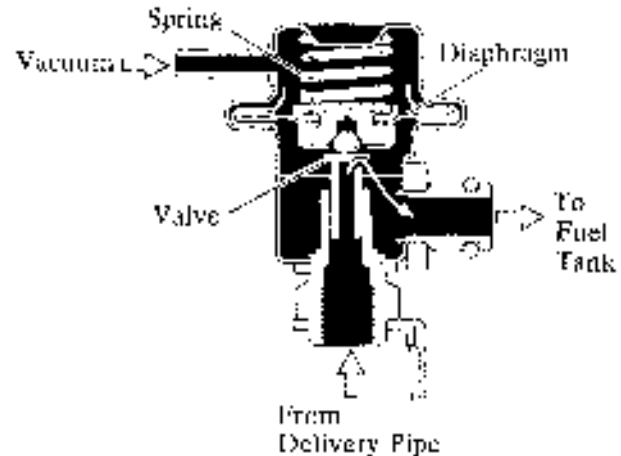

b. Operation

Pressurized fuel from the delivery pipe pushes on the diaphragm, opening the valve. Part of the fuel flows back to the fuel tank through the return pipe. The amount of fuel return depends on the extent of the diaphragm spring tension and the fuel pressure varies according to the return fuel volume.

Intake manifold vacuum is led to the chamber of the diaphragm spring side, weakening the diaphragm spring tension, increasing the volume of return fuel and lowering the fuel pressure. In short, when intake manifold vacuum rises (less pressure), fuel pressure falls only to the extent of the decrease in pressure, so that sum of the fuel pressure A and the intake manifold vacuum B is maintained at a constant.

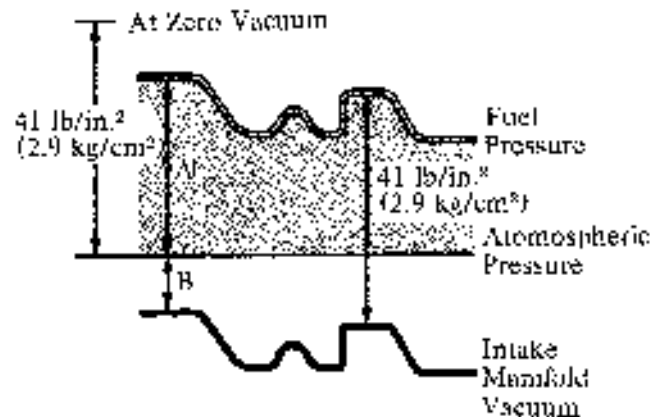

The valve is closed by the spring when the fuel pump stops. As a result, the check valve inside the fuel pump and the valve inside the pressure regulator maintain residual pressure inside the fuel line.

- The 1UZ-FE engine has a fuel pressure control (ECU controlled) system which maintains the fuel pressure at higher levels than normal for a predetermined time when the engine is hot when started, maintaining the engine startability and the idle stability. See page 150 for detail.

6) Fuel Injector

Fuel is injected into the intake port of each cylinder in accordance with injection signals from the ECU.

At the tip of the injector, there are two injection holes.

The light and small plunger permits quick response to signals from the ECU.

When a signal from the ECU is received by the solenoid coil, the plunger is pulled against spring force. Since the valve needle and plunger are a single unit, the valve needle is also pulled from its seat and fuel is injected.

Fuel volume is controlled by the duration of the signal.

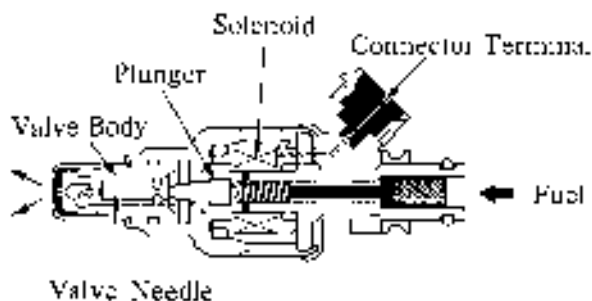

7) Cold Start Injector

The cold start injector injects fuel into the intake air chamber during engine cranking to improve startability.

In starting the engine when the engine coolant temperature is 71.6°F (22°C) or lower, the cold start injector's operation time is controlled by the start injector time switch.

However, starting the engine when engine coolant temperature is 140°F (60°C) or lower, the operation time of the cold start injector is controlled by the ECU.

Thus, the cold start injector is controlled by the start injector time switch and the ECU simultaneously when the coolant temperature is below 71.6°F (22°C).

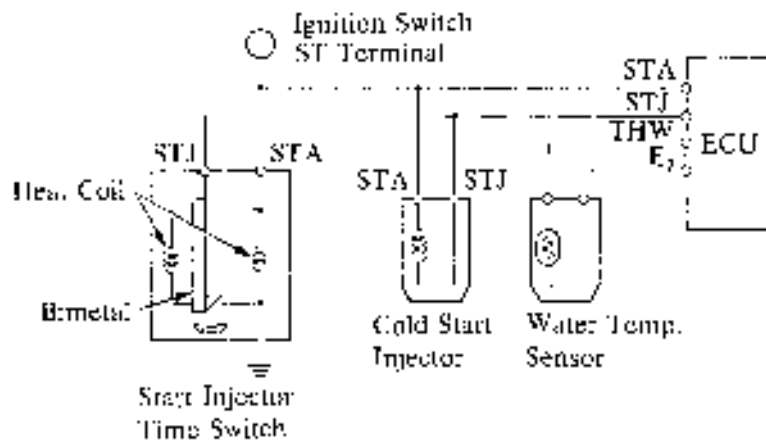
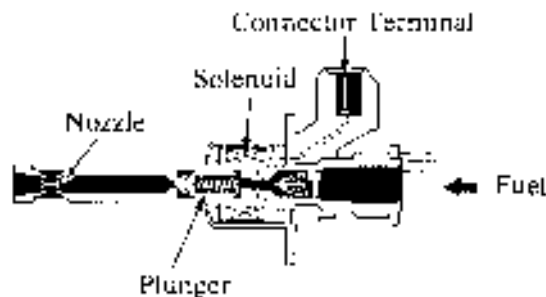

Air Induction System

1) General

Air cleaned by the air cleaner enters the air intake chamber according to the throttle valve opening in the throttle body and the engine speed. An optical Karman–Vortex type air flow meter is provided between the air cleaner and the throttle body to optically detect the frequency of the Karman–Vortex that is generated when the air passes to measure the amount of air being taken into the engine.

A throttle valve in the throttle body controls the air volume.

The air regulated by the throttle valve enters the air intake chamber, is distributed to the intake manifold of each cylinder and enters the combustion chamber.

ISC (Idle Speed Control) valve is also provided on the throttle body and directs the intake air bypassing the throttle body to the air intake chamber. The amount of air bypassing the throttle body is determined by a signal from the ECU to control the idle speed and fast idle speed accordingly.

The air intake chamber prevents pulsation of the intake air to minimize the adverse affection to the air flow meter. This helps to increase accuracy of measurement of the intake air volume. It also prevents intake air interference in cylinders.

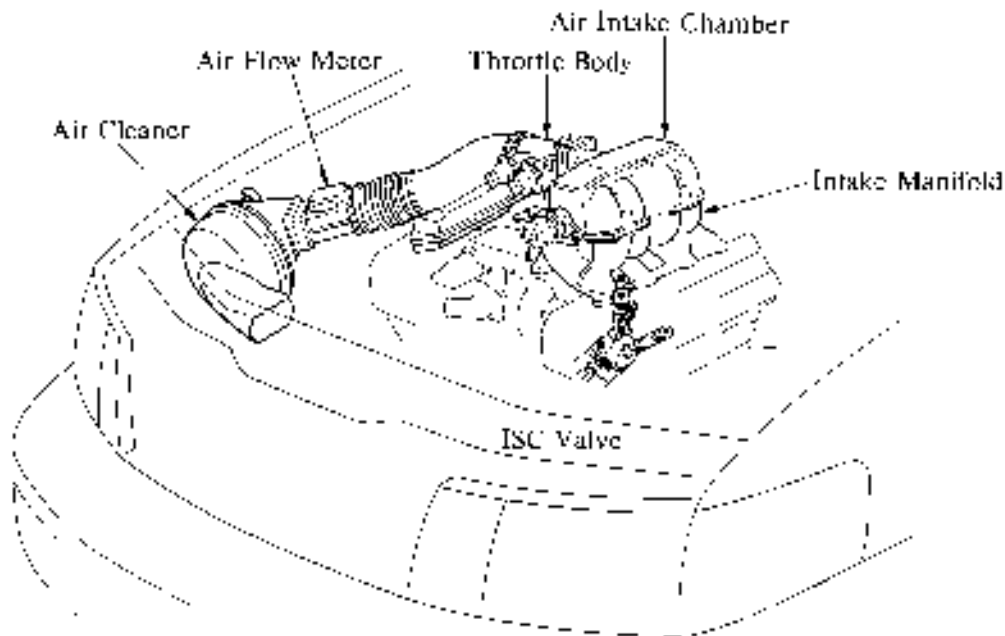
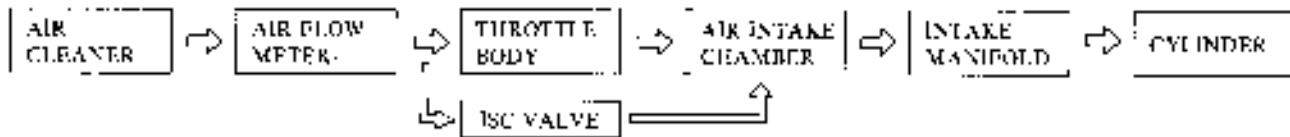

2) Construction and Operation of Main Components

a. Air Flow Meter

• Description

An optical Karman–Vortex type air flow meter is used.

This air flow meter measures the intake air volume electrically, enabling precise detection. It is made compact and lightweight. The simplified construction of the air passage also reduces air intake resistance.

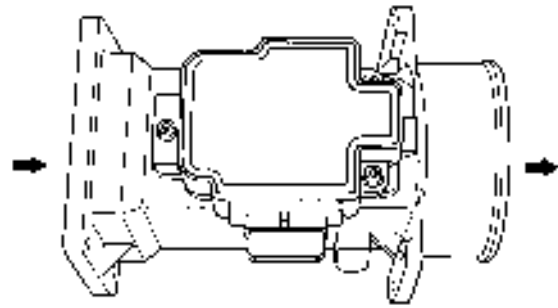

• Principle

Karman–Vortex Street

When a cylindrical object (Vortex generating body) is placed in the path of gaseous current, vortices (called Karman–Vortex) are generated in the wake of the object. If the Karman–Vortex frequency is f , the air velocity V and the diameter of the cylindrical object d , then the following equation can be made:

$$f = \frac{0.2 V}{d}$$

• Construction and Operation

Using the above principle, the air flow meter is fitted with a vortex generator. As air flows past the vortex generator, vortices are generated at a frequency proportional to the velocity of the air flow.

A calculation of the frequency can then determine the amount of air flow.

The vortices are detected by subjecting the surface of thin metal foil (mirror) to the pressure of the vortices and optically detecting the vibrations in the mirror by means of a luminous diode and a photo transistor.

The intake air volume signal (K_s) is the pulse signal. When the intake air volume is low, this signal has a low frequency. When the intake air volume is high, it has a high frequency.

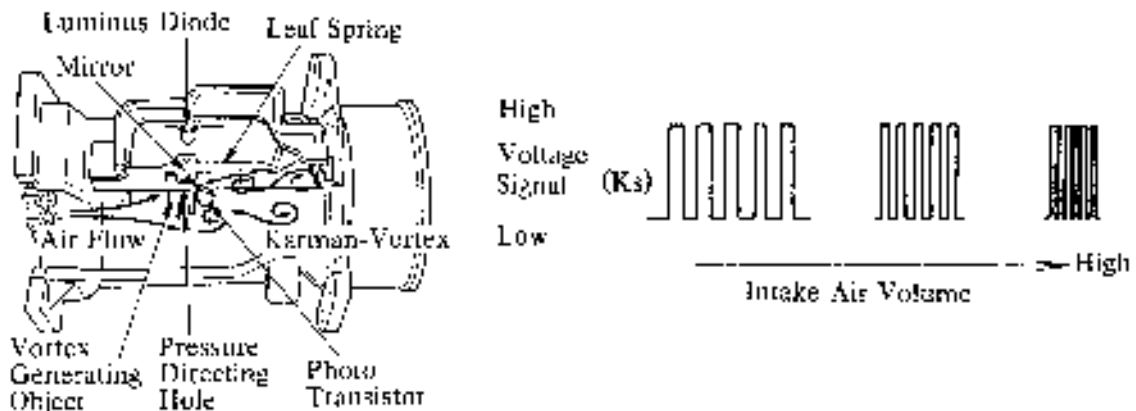

b. Throttle Body

The throttle body contains the throttle valve that regulates the amount of intake air, the throttle position sensor that detects the throttle valve opening, and the dash pot that reduces the closing speed of the throttle valve.

The throttle body has the following features:

- The throttle body contains a throttle valve, sufficiently large in diameter to meet the large engine displacement.
- A linear type throttle position sensor is mounted on the throttle valve shaft.

This sensor detects the throttle valve opening angle, converts it to a voltage and sends it to the engine and transmission ECU.

(Refer to the next page for detail.)

- Engine coolant passes through the throttle body to maintain warmth under cold weather conditions.
- When the optional TRAC (Traction Control) is fitted, a sub-throttle actuator, sub-throttle valve and sub-throttle position sensor are added to the throttle body.

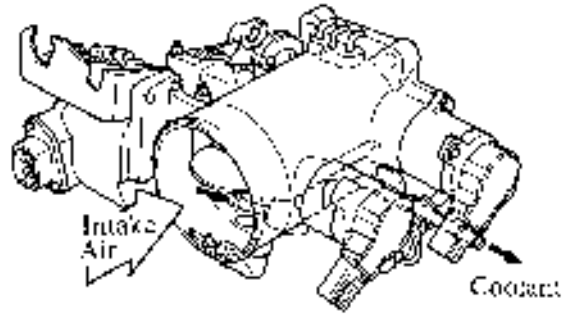

• Throttle Position Sensor

The throttle position sensor is mounted on the throttle body. This sensor converts the throttle opening angle into a voltage and sends it to the ECU as the throttle position signal.

A constant 5V is applied to the Vcc terminal from the ECU. As the contact slides along the resistor in accordance with the throttle valve opening angle, a voltage is applied to the V_{TA} terminal in proportion to this angle.

When the throttle valve is closed completely, the contact for the IDL signal connects between the IDL and E₂ terminals.

Another throttle position sensor for the sub-throttle valve is added to the vehicle with the optional TRAC (Traction Control). It is the same as the main throttle position sensor in construction and operation.

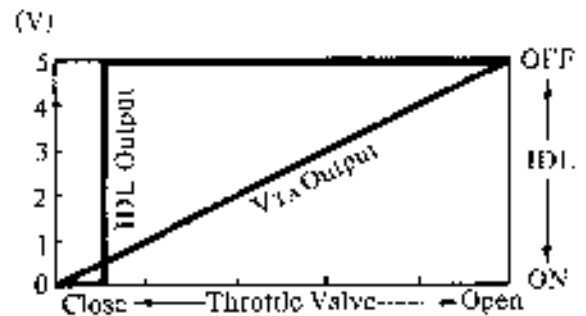
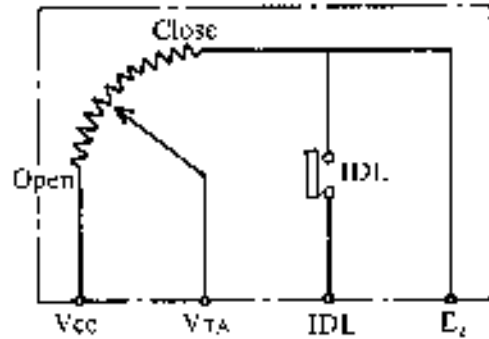
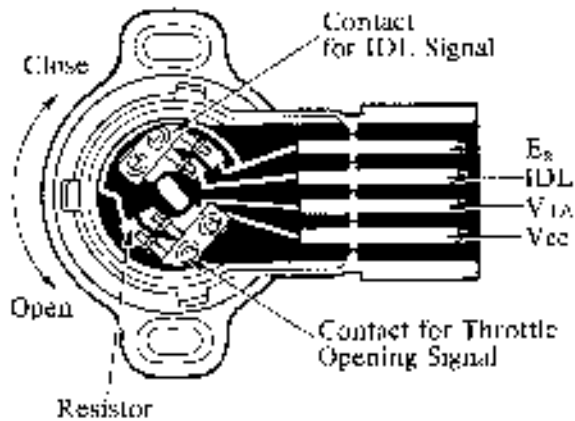

Electronic Control System

1) General

The ECU incorporates a built-in microprocessor. It controls injection duration precisely based on the data stored in its memory and signals from each sensor.

Also, the ECU, based on this injection duration, controls the ignition timing.

Further, the fuel injection system is a four group injection system.

The ECU controls to inject fuel into two cylinders simultaneously once every two engine revolutions.

• Fuel Injection Timing ◀

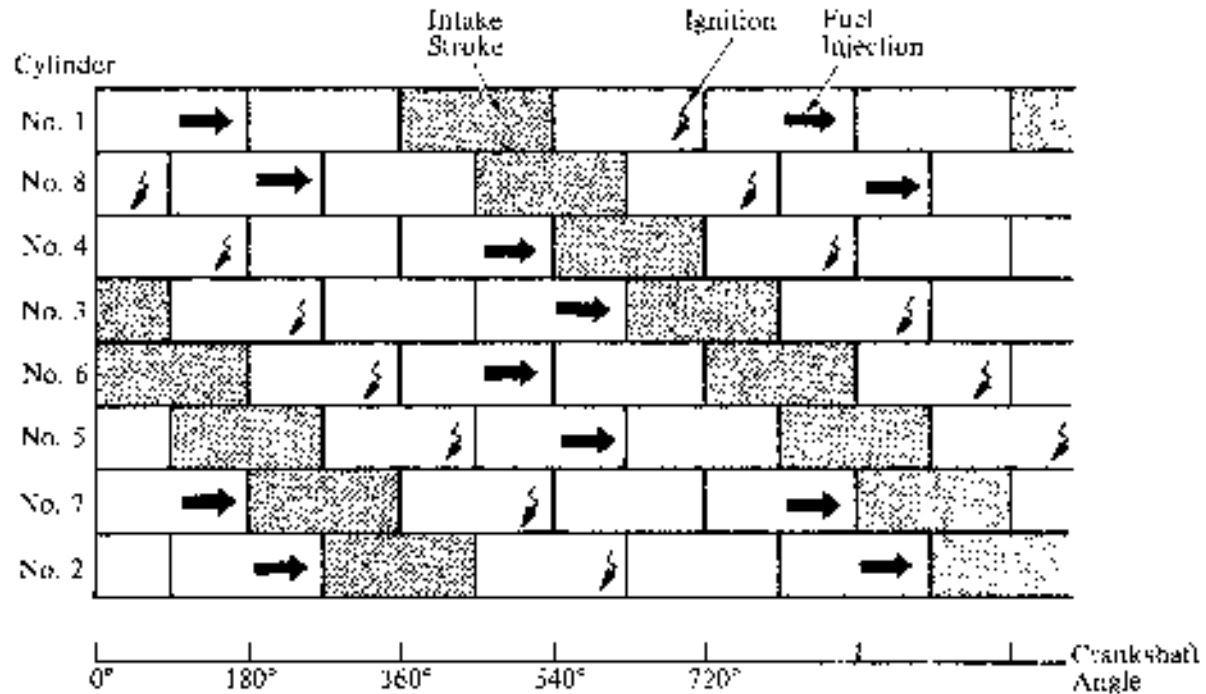

2) Construction and Function of Relevant Sensors

a. Cam Position Sensors and Engine Speed Sensor

• General

Revolution of the G signal plate on the camshaft and Ne signal plate on the crankshaft alters the air gap between the projection of the plate and the G pickup coil (or the Ne pickup coil). The change in the gap creates an electromotive force in the pickup coil. This voltage appears as an alternating output since it reverses its direction periodically as the plate approaches and leaves the pickup coil.

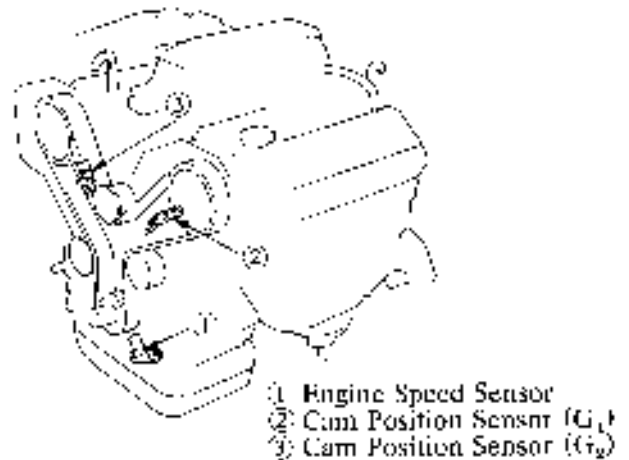

• Cam Position Sensors (G_1 and G_2 signals)

The G_1 signal informs the ECU of the standard crankshaft angle, which is used to determine injection timing and ignition timing in relation to TDC of No. 6 cylinder. G_2 sensor conveys the same information for No. 1 cylinder.

These sensors are made up of (1) signal plate, which is fixed to the camshaft timing pulley and turn once for every two rotations of the crankshaft, and (2) the two sensors (G_1 and G_2 sensors), which are fitted to the distributor housing.

The G_1 , G_2 signal plates are provided with a projection which activates the G_1 and G_2 sensors once for each rotation of the camshaft, generating the wave forms as shown in the chart. From these signals, the ECU detects when the No. 6 and No. 1 pistons are near their TDC.

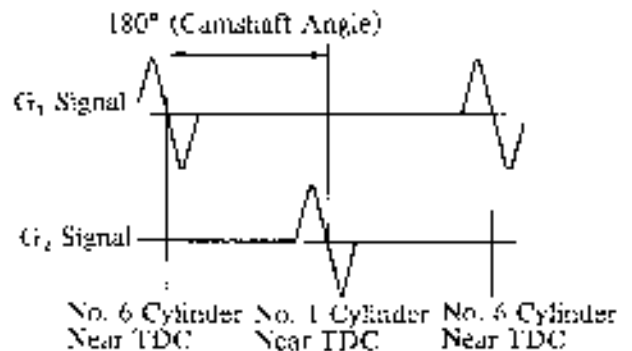
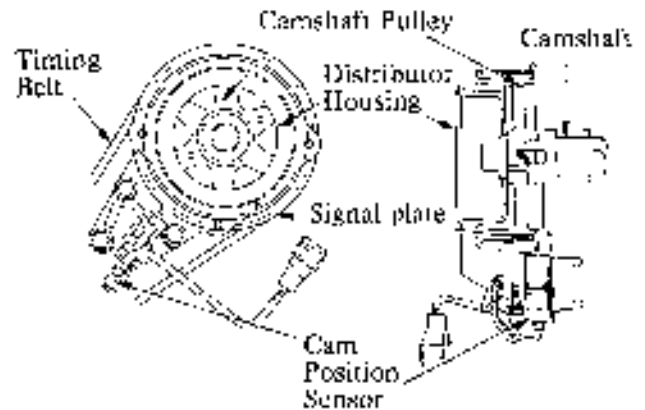

• **Engine Speed Sensor (Ne signal)**

The Ne signal is used by the ECU to detect the actual crankshaft angle and the engine speed. The ECU determines the basic injection duration and basic ignition advance angle by these signals. Ne signals are generated in the Ne sensor by the Ne signal plate like the G₁ and G₂ signals. The only difference is that the signal plate for the Ne signal has 12 teeth. Therefore, 12 Ne signals are generated per engine rotation.

From these signals, the ECU detects the engine speed as well as each 30° change in the engine crankshaft angle.

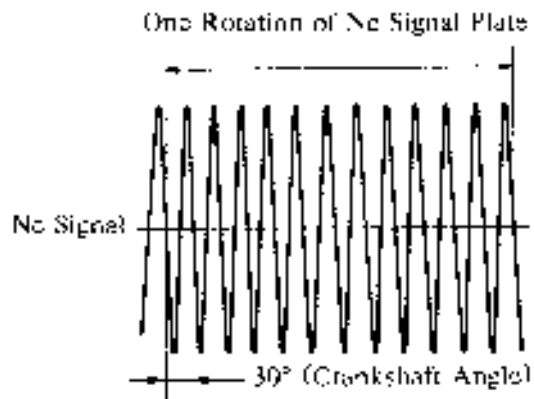
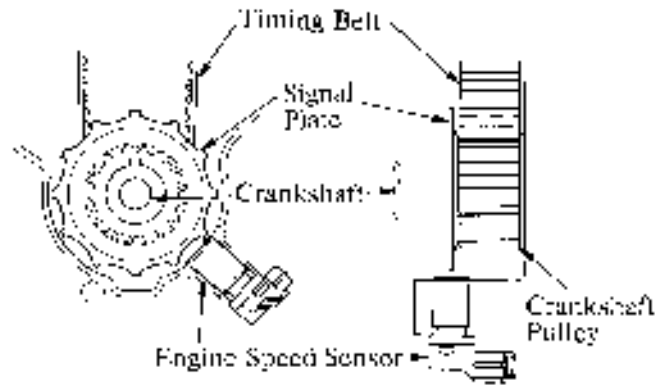

b. Oxygen Sensors

Four oxygen sensors in total are fitted, one each in front of and after the start catalyst converters. The one in front of the catalyst converter is the main oxygen sensor and after the converter is the sub-oxygen sensor. The main and sub-oxygen sensors are identical in construction and function, except for the fact that the main oxygen sensor has a heater.

The O₂ sensor consists of a test tube shaped zirconia element with a thin layer of platinum coated to both the inside and outside. This sensor is fitted to the exhaust manifolds and exhaust pipes on both the left and right sides to sense oxygen concentration (air-fuel ratio) in the exhaust gas. If there is a difference in the oxygen concentration on the two sides of the zirconia element, an electromotive force is generated, or if the temperature of the O₂ sensor becomes high, the platinum acts as a catalyst, causing the oxygen in the exhaust gas to react with the CO. This decreases the oxygen volume in the gas. The zirconia element's electromotive force changes suddenly at the boundary near the ideal air-fuel ratio.

Using these properties, exhaust gas is passed over the outer surface of the O₂ sensor and atmospheric air is introduced into the inside of the sensor. The sensor accurately detects whether the oxygen concentration, that is, the air-fuel ratio, is higher (rich) or lower (lean) than the ideal air-fuel ratio.

If the air-fuel is rich, the zirconia element generates high voltage (approximately 1V). This "rich" signal is sent to the ECU. Conversely, if the air-fuel ratio is lean, the electromotive force of the O₂ sensor is low. The ECU increases or decreases the injection volume in accordance with these signals.

A heater is provided in the sensors which are fitted to the exhaust manifolds. It heats the zirconia element. This heater is controlled by the ECU. When the intake air volume is low (the exhaust gas temperature is low), current flows to the heater, maintaining the sensor accuracy.

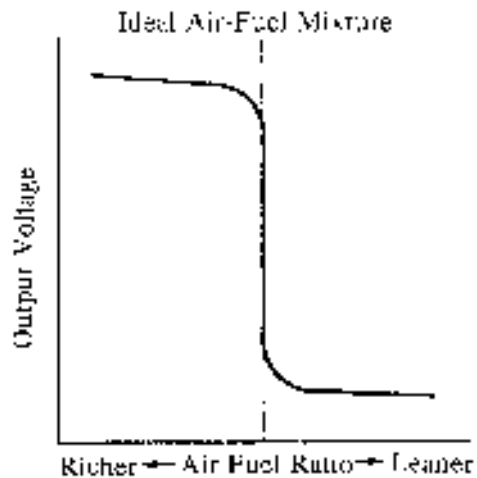
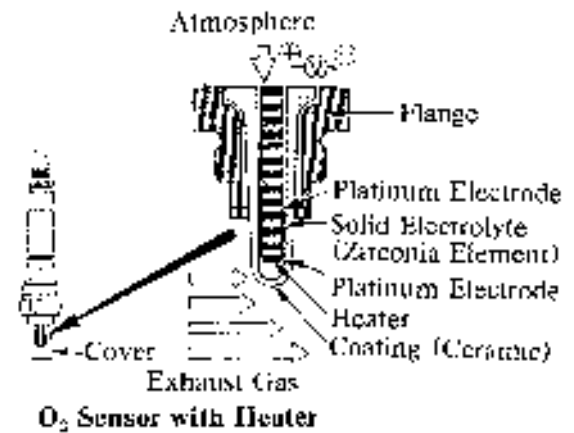
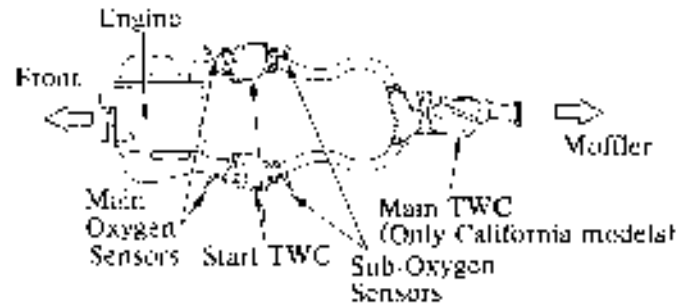

3) Functions of the ECU

a. Determination of Injection Timing

When the ECU receives the G_1 signal from the cam position sensor and then the Ne signal from the engine speed sensor in this order, it determines that the crankshaft angle at No. 6 cylinder is at 5° BTDC position.

When the Ne signal is received immediately after the G_2 signal, it judges that the crankshaft angle at No. 1 cylinder is at 5° BTDC. The ECU accurately calculates the crankshaft angle based on G_1 , G_2 and Ne signals and determines the injection timing accordingly.

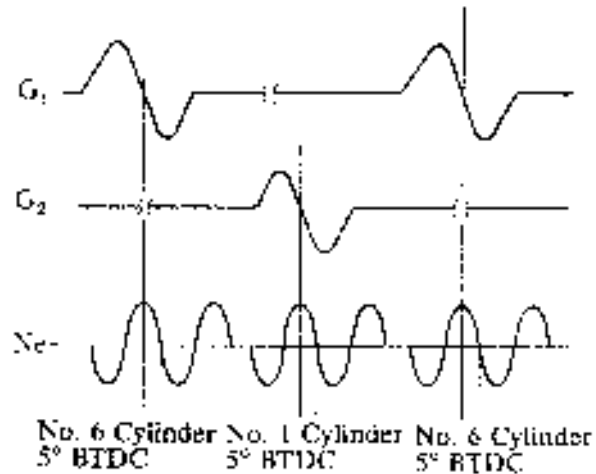

b. Principle of Fuel Injection Duration Control

The fuel injection duration is determined by the basic injection duration which is determined by intake air volume and the engine speed, plus any compensation based on signals from various sensors. During engine starting (cranking), it is determined differently because the amount of intake air is not stable during cranking. Once the engine is started, the ECU determines the duration of injection in the following steps:

Step 1: Determination of Basic Injection Duration

The ECU selects, from the data stored in its memory, an injection duration that is suitable for the intake air volume (detected by the air flow meter) and the engine rpm (detected by the engine speed sensor).

This injection duration is called the “basic injection duration.”

Step 2: Determination of Adjusted Duration of Injection

Under most engine condition, the engine runs smoothly at an air–fuel mixture ratio of approximately 14.7 (this is called the “ideal air–fuel ratio”). However, when the engine is still cold, or when an extra load is applied to the engine, the air–fuel ratio is reduced to below 14.7 (i.e., it becomes richer). The ECU detects these engine conditions by means of the water temp. sensor, throttle position sensor and intake air temp. sensor, etc., and corrects the basic injection duration to optimize it for the existing engine conditions.

Also, even under normal engine conditions, the injection duration is corrected by the signals from the oxygen sensors to keep the air–fuel ratio within a narrow range near 14.7. The corrected time is called the “adjusted injection duration”.

Step 3: Determination of Injection Signal Length

There is a slight delay between the time the ECU sends an injection signal to the injectors and the time the injectors actually open.

This delay becomes longer the more the voltage of the battery drops.

The ECU compensates for this delay by lengthening the injection signal by a period corresponding to the length of the delay.

This corrects the actual injection period so that it corresponds with that calculated by the ECU.

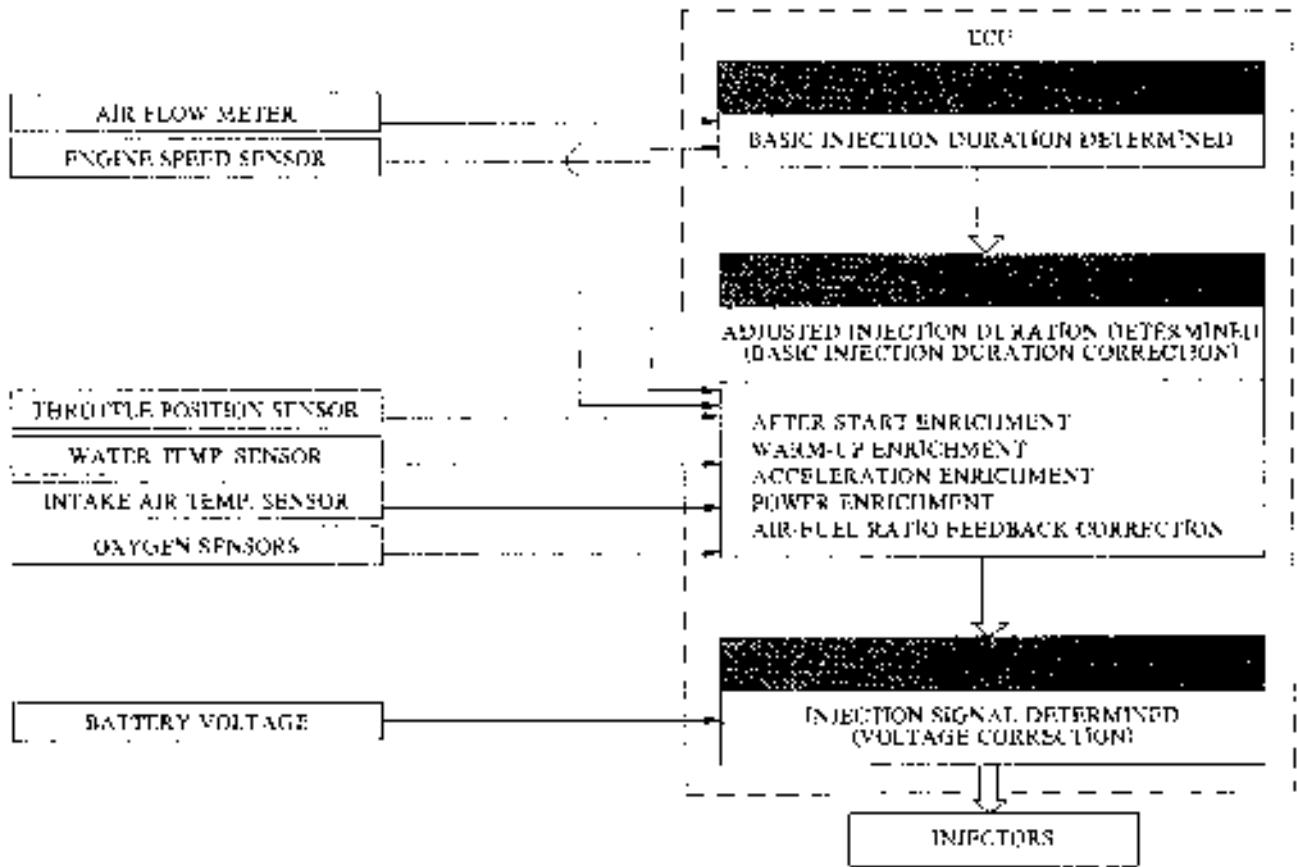

c. Starting Injection Control

During engine starting, it is difficult for the air flow meter to accurately sense the amount of air being taken in due to large fluctuations in rpm.

For this reason, the ECU selects from its memory an injection duration that is suitable for the coolant temperature, regardless of intake air volume or engine rpm. It then adds to this an intake air temperature correction and a voltage correction, to obtain the injection duration.

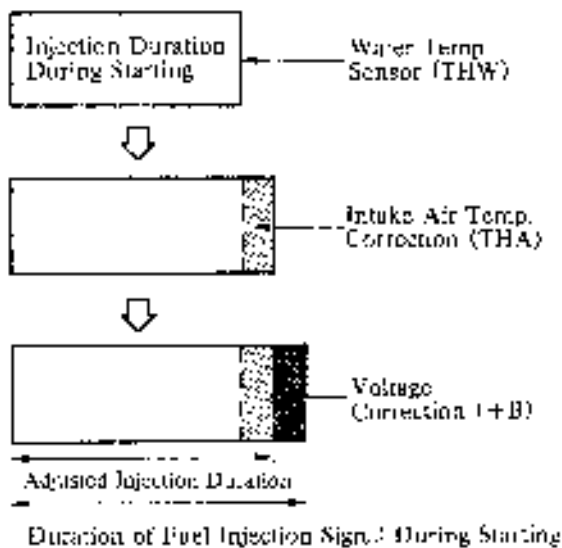

- RELEVANT SIGNALS
- Engine speed (Ne)
 - Coolant temperature (THW)
 - Intake air temperature (THA)
 - Ignition switch (STA)
 - Battery voltage (+B)
 - Throttle position sensor (VTA₁, VTA₂)

- CONDITIONS
- Engine speed below a predetermined level, or STA on.

d. After-Start Injection Control

When the engine is running more or less steadily above a predetermined level rpm, the ECU determines the injection signal duration as explained below:

Injection Signal Duration

= Basic Injection Duration

x Injection Correction Coefficient*

+ Voltage Correction

* Injection correction coefficient is calculated by the sum and product of various correction coefficients.

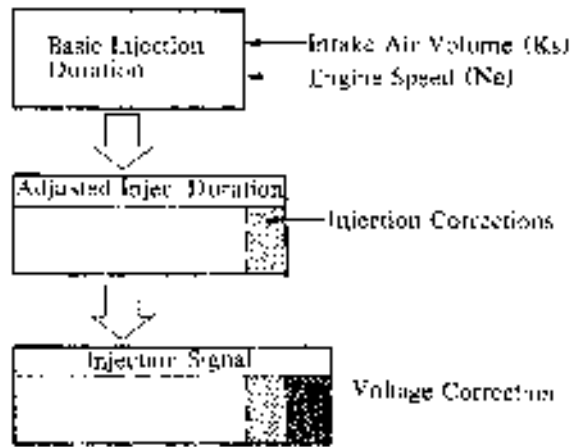

i) Basic Injection Duration

This is the most basic injection duration, and is determined by the volume of air being taken in (Ks signal) and the engine speed (Ne signal). The basic injection duration can be expressed as follows:

$$\text{Basic Injection Duration} = K \frac{\text{Intake Air Volume}^*}{\text{Engine Speed}} \quad \text{where K: Correction Coefficient}$$

* The intake air volume may vary with the air density due to fluctuation of the air temperature and atmospheric pressure. The variation of air density is corrected as follows:

• Intake Air Temperature Correction

The density of the intake air will change depending upon its temperature. For this reason, the ECU must be kept accurately informed of both the intake air volume (by means of the air flow meter) and the intake air temperature (by means of the intake air temp. sensor) so that it can adjust the injection duration to maintain the air-fuel ratio currently required by the engine. For this purpose, the ECU considers 68°F (20°C) to be the “standard temperature” and increases or decreases the amount of fuel injected, depending upon whether intake air temperature falls below or rises above this standard.

RELEVANT SIGNAL
Intake air temperature (THA)

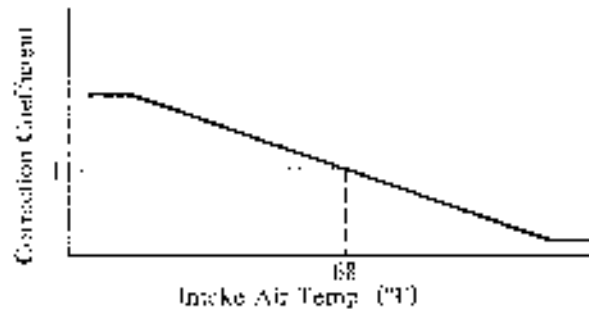

- **High Altitude Compensation**

The density of oxygen in the atmosphere is smaller at high altitudes. If the fuel is injected under the same conditions as sea level, the amount of intake air volume measured by the air flow meter for mixture with the fuel will be insufficient and the air-fuel mixture becomes too rich.

For this reason, the ECU, according to signals from the high altitude compensation sensor, adjusts signals from the air flow meter and determines the corresponding fuel injection volume.

RELEVANT SIGNAL —
High altitude compensation (HAC)

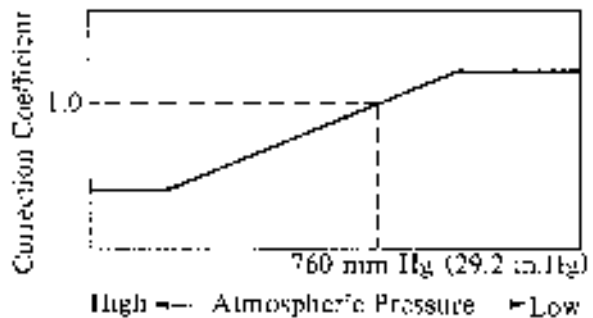

ii) Injection Corrections

The ECU is kept informed of the engine running conditions at each moment by means of signals from various sensors, and makes various corrections in the basic injection duration based on these signals.

- **After-Start Enrichment**

Immediately after starting (engine speed above a predetermined rpm), the ECU causes an extra amount of fuel to be supplied for a certain period to aid in stabilizing engine operation.

The initial correction value is determined by the coolant temperature, and the amount gradually decreases thereafter at a certain constant rate.

RELEVANT SIGNAL —

- Engine speed (Ne)
- Coolant temperature (THW)

CONDITION —
Engine speed above a predetermined rpm

- **Warm-Up Enrichment**

As fuel vaporization is poor when the engine is cold, if a richer fuel mixture is not supplied, the engine will run poorly.

For this reason, when the coolant temperature is low, the water temp. sensor informs the ECU to increase the amount of fuel injected to compensate.

As the coolant warms up, the amount of warm-up enrichment decreases, reaching zero (correction coefficient = 1.0) when the coolant reaches 140°F (60°C).

RELEVANT SIGNAL —

- Engine speed (Ne)
- Coolant temperature (THW)

- **Acceleration Enrichment During Warm-Up**

The ECU causes an extra fuel to be supplied during acceleration when the engine is still warming up in order to aid drivability.

Through calculation of the amount of change in the intake air volume per engine revolution, the ECU detects the engine acceleration or deceleration condition. The correction value is determined according to the coolant temperature and the strength of acceleration or deceleration.

The control is performed separately for each bank.

RELEVANT SIGNALS

- Air flow meter (Ks)
- Engine speed (Ne)
- Coolant temperature (THW)
- Intake air temperature (THA)
- Ignition switch (STA)
- High altitude compensation (HAC)

CONDITIONS

Intake air volume per engine revolution changes (acceleration or deceleration) with coolant temperature below 176°F (80°C).

However, if any of the following occurs, the ECU stops calculating this change and halts the injection of extra fuel:

- Engine speed falls below a predetermined rpm
- Fuel cut-off occurs
- Intake air volume becomes smaller than a certain level

- **Power Enrichment**

When the engine is operating under heavy load conditions, the injection volume is increased in accordance with the engine load in order to ensure good engine operation.

The correction value is determined according to the intake air volume or throttle valve opening angle.

RELEVANT SIGNALS

- Throttle position ($V_{TA1,2}$)
- Air flow meter (Ks)
- Engine speed (Ne)
- Coolant temperature (THW)
- Intake air temperature (THA)
- High altitude compensation (HAC)

CONDITIONS

Throttle valve opening angle above 60° or intake air volume larger than a certain level.

• Air-Fuel Ratio Feedback Correction

The ECU corrects the ignition duration based on the signals from the main oxygen sensors to keep the air-fuel ratio within a narrow range near the ideal air-fuel ratio. (Closed loop operation)

Further, in order to prevent overheating of the catalyst and assure drivability under the following conditions, the air-fuel ratio feedback operation does not work: (Open loop operation)

- During engine starting
- During traction control
- During after-start enrichment
- Fuel cut-off occurs
- Coolant temperature below a predetermined level

The ECU compares the voltage of the signals sent from the main oxygen sensors with a predetermined voltage.

As a result, if the voltage of the signal is higher, the air-fuel ratio is judged to be richer than the ideal air-fuel ratio and the amount of fuel injected is reduced at a constant rate. If the voltage of the signal is lower, it is judged that the air-fuel ratio is leaner than the ideal, so the amount of fuel injected is increased.

In addition, the ECU corrects the skip amount of “rich” or “lean” mixture based upon signals from the two sub-oxygen sensors. This implements a more accurate feedback correction.

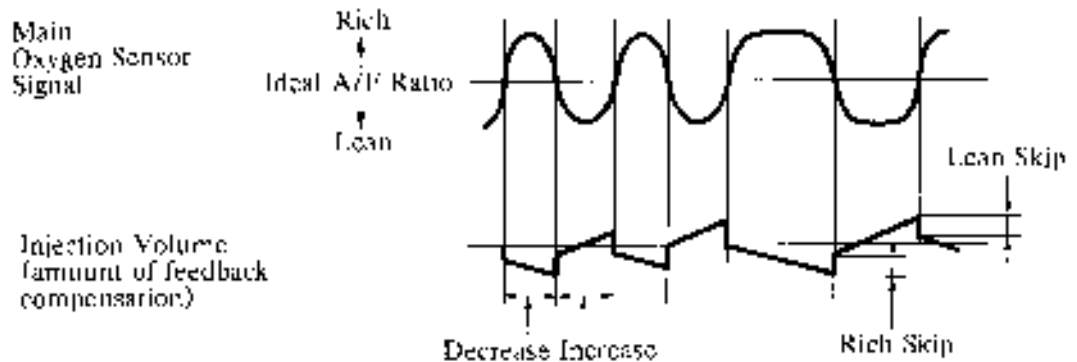

The control is performed separately for each bank.

iii) Voltage Correction

There is a slight delay between the time the ECU sends an injection signal to the injectors actually open. This delay becomes longer the more the voltage of the battery drops.

This means that the length of time that the injector valves remain open would become shorter than that calculated by the ECU, causing the actual air-fuel ratio to become higher (i.e., leaner) than that required by the engine, if this were not prevented by voltage correction.

In voltage correction, the ECU compensates for this delay by lengthening the injection signal by a period corresponding to the length of the delay. This corrects the actual injection period so that it corresponds with that calculated by the ECU.

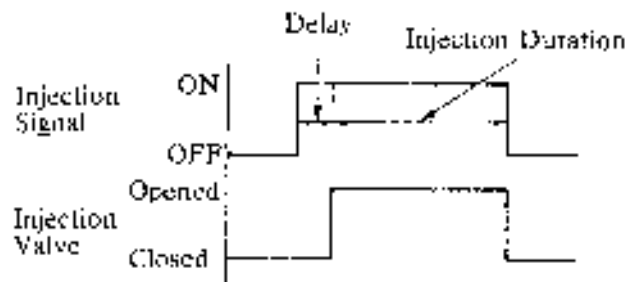

RELEVANT SIGNALS

Battery voltage (+B)

e. Fuel Cut-Off

• Fuel Cut-Off During Deceleration

During deceleration from a high engine speed with the throttle valve completely closed, the ECU halts injection of fuel in order to improve fuel economy and emission.

When the engine speed falls below a certain rpm or throttle valve is opened, fuel injection is resumed. These fuel cut-off and fuel injection resumption speeds are high when the coolant temperature is low.

RELEVANT SIGNALS

- Throttle position (IDL₁)
- Engine speed (Ne)
- Coolant temperature (THW)

CONDITION

IDL contacts are closed with engine speed above fuel cut-off speed.

CONDITIONS FOR RESUMPTION OF FUEL INJECTION

Engine speed drops below fuel injection resumption speed, or IDL contacts are open.

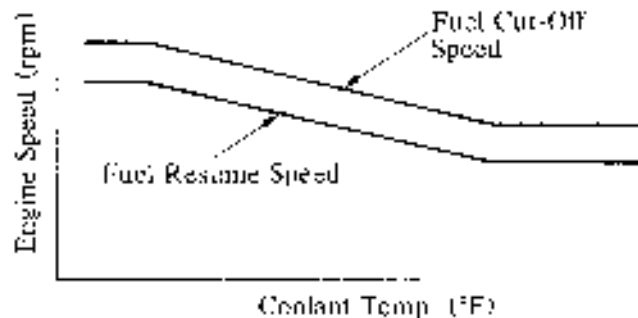

• Fuel Cut-Off Due to High Engine Speed

To prevent engine over-run, fuel injection is halted if the engine speed rises above 6500 rpm. Fuel injection is resumed when the engine speed falls below this level.

f. Cold Start Injector Control

To improve startability when the engine is cold, the injection duration of the cold start injector is controlled not only by the start injector time switch but by the ECU in accordance with the coolant temperature. Once the engine has been started, current to the cold start injector is cut off and injection is terminated.

RELEVANT SIGNALS

- Coolant temperature (THW)
- Ignition switch (STA, IGSW)
- Engine speed (Ne)

CONDITION

The engine is cranking and the coolant temperature is below 140°F (60°C).

7. ESA (Electronic Spark Advance)

General

In order to maximize engine output efficiency, the air-fuel mixture must be ignited when the maximum combustion pressure occurs; that is, at about 10° after TDC. However, the time from ignition of the air-fuel mixture to the maximum combustion pressure varies depending on the engine speed and the intake air volume. Ignition must occur earlier when the engine speed is higher. In the conventional system, the timing is advanced by the governor advancer. When the intake air volume per engine revolution is small (high vacuum), ignition must also be advanced, and this is achieved by the vacuum advancer in the conventional system.

Actually, optimum ignition timing is affected by a number of other factors, such as the shape of the combustion chamber and the temperature inside the combustion chamber, etc., in addition to the engine speed and the intake air volume. Therefore, the governor and vacuum advance do not provide ideal ignition timing for the engine.

With the ESA (Electronic Spark Advance) system, the engine is provided with nearly ideal ignition timing characteristics.

The ECU determines ignition timing from its internal memory, which contains optimum ignition timing data for each engine condition, based on signals detected by various sensors, and then sends signals to the igniter.

Since the ESA always ensures optimum ignition timing, both fuel efficiency and engine power output are maintained at optimum levels.

• Vacuum Advancing ◀

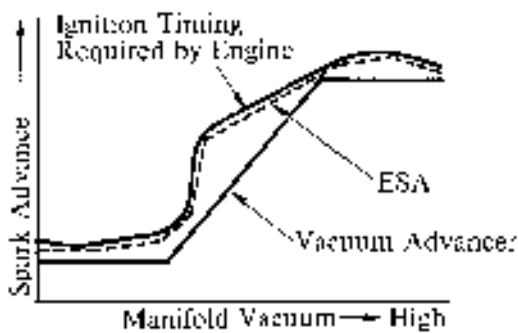

• Governor Advancing ◀

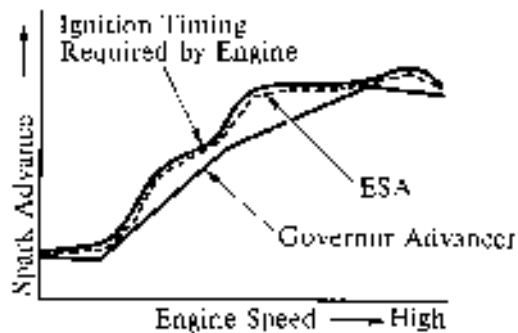

• ESA ◀

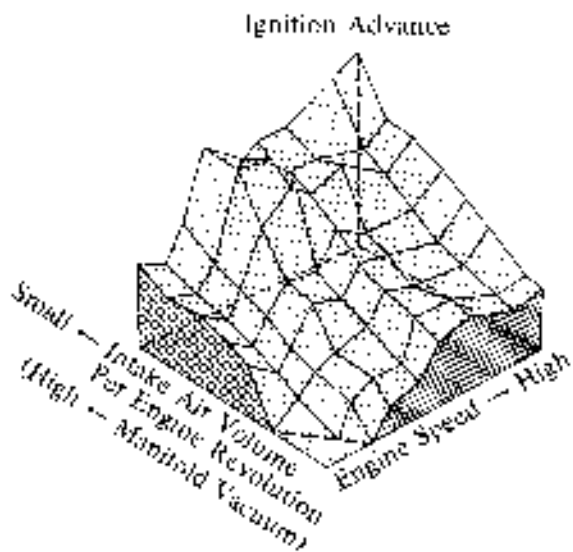

• Conventional ◀

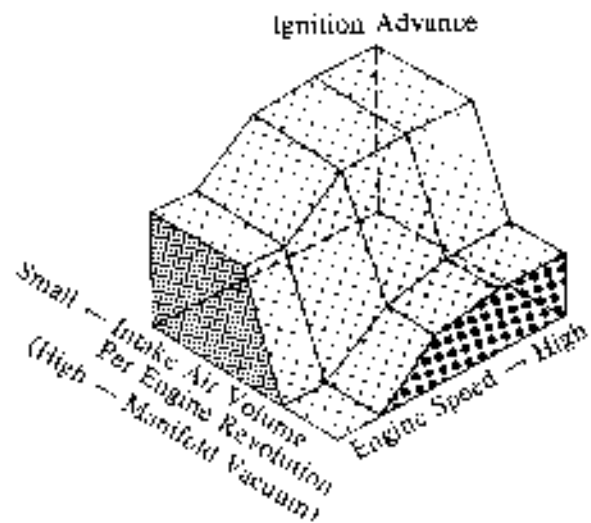

Ignition Circuit

1) Principle of Ignition

The ignition timing is determined by the ECU based on signals (G_1 , G_2 , Ne) from sensors. When it is determined, the ECU sends an IGT signal to the igniter at a predetermined timing (30° crankshaft angle) before ignition. The transistor inside the igniter is turned on by this signal and primary current is supplied from the battery via the ignition switch to the ignition coil. When the crankshaft position reaches the ignition timing, the ECU stops supplying the IGT signal. The transistor inside the igniter is turned off and the primary current to the ignition coil is cut off as a result. At this time, the secondary voltage is induced in the ignition coil. The secondary voltage is distributed and causes sparks from the spark plug. The counter-electromotive force that is generated when the primary current is shut off causes an ignition confirmation signal (IGf), which is sent to the igniter.

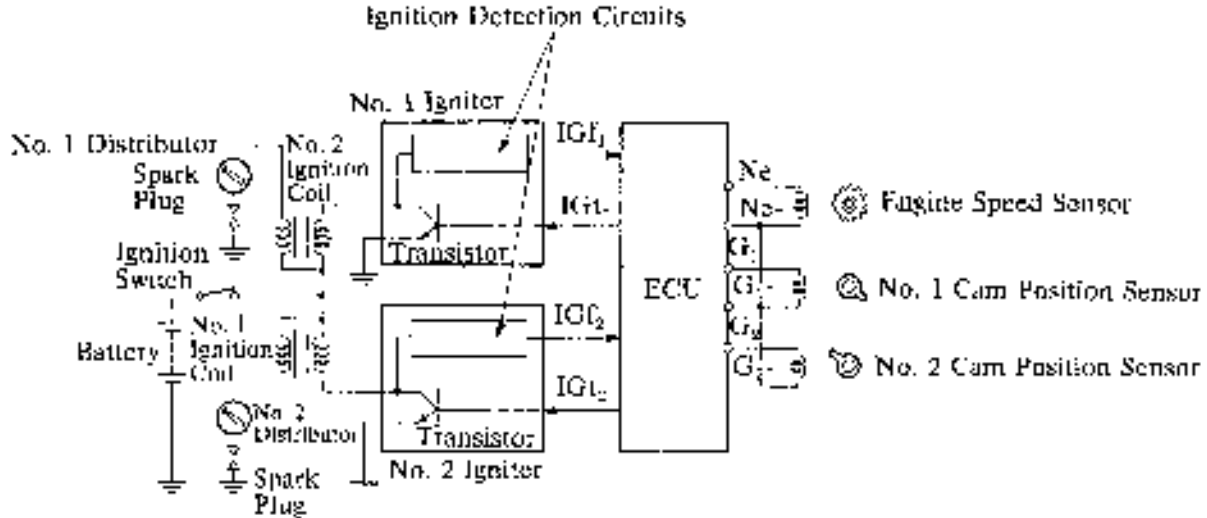

NOTE: Two igniters are used in the engine, one each for four cylinders. No. 1 igniter ignites cylinders 1, 4, 6 and 7 and No. 2 igniter ignites cylinders 2, 3, 5 and 8.

2) Layout of Components

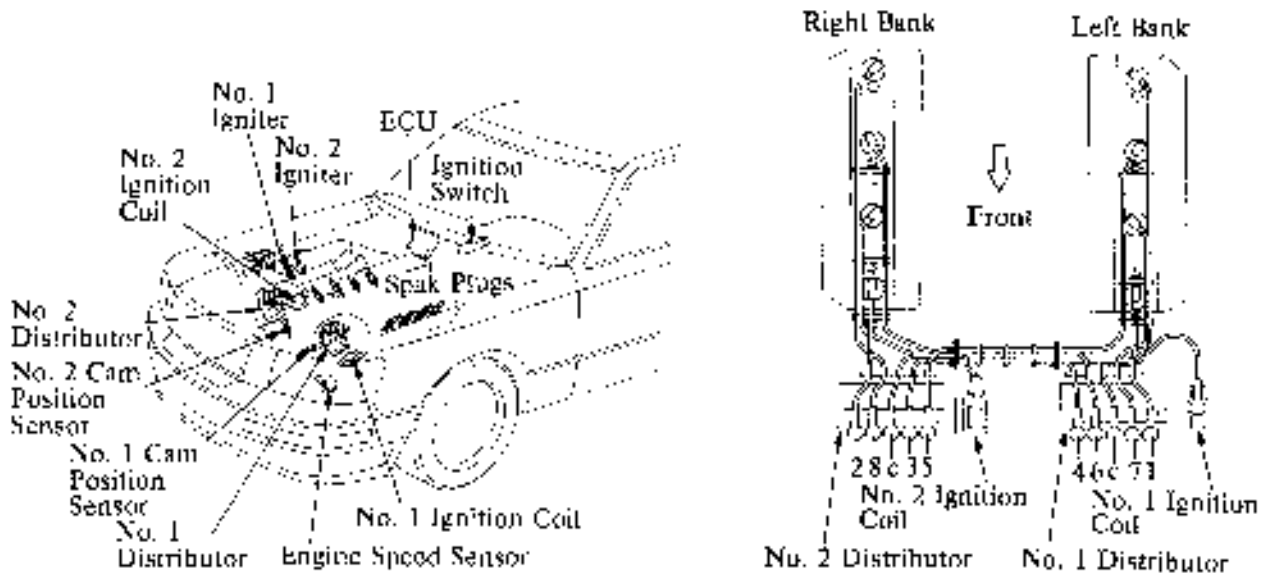

Construction and Function of Relevant Sensor

Knock Sensor

The knock sensor is provided on the left and right banks of the cylinder block. A piezoelectric ceramic element is incorporated into the sensor.

If knocking develops in the engine, this piezoelectric element, by resonating with the knocking vibration, generates a voltage which corresponds with the knocking strength and sends a signal to the ECU.

The ECU uses this signal to retard the ignition timing to prevent the knocking.

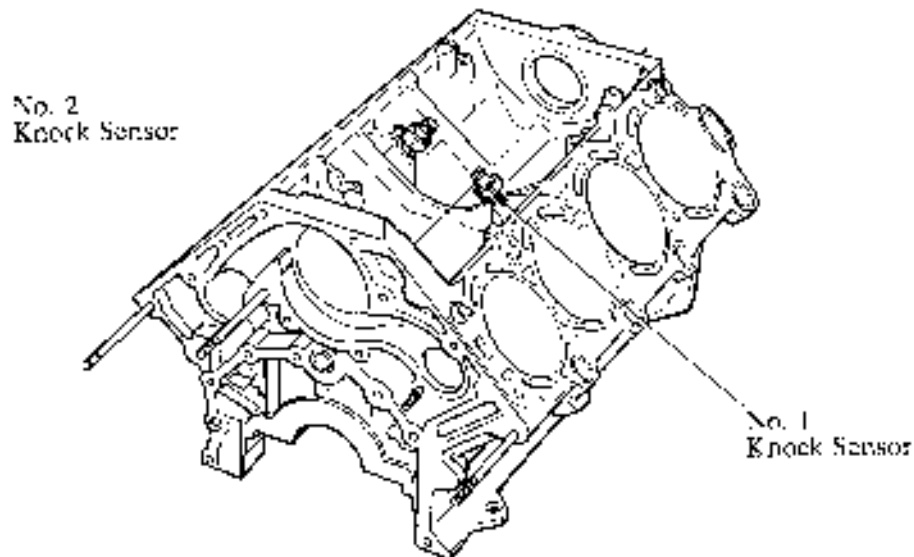
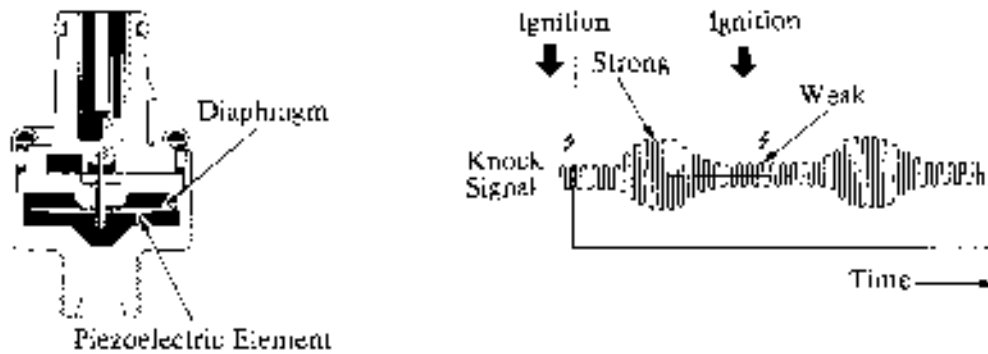

—REFERENCE—

Excessive knocking may damage the engine.

However, the engine operation in a marginal knocking condition is the most advantageous to the engine output and fuel economy.

Function of ECU

1) The function of the ECU in the ESA control is divided into the following three items:

a. Judging Crankshaft Angle

In order to control the ignition timing, it is necessary for the ECU to know where compression top dead center is. In this engine, the ECU judges that the crankshaft has reached 5° BTDC of the compression cycle when it receives the first Ne signal following a G₁ (or G₂) signal.

Therefore, the ECU calculates the ignition timing, and advances or retards the timing accordingly, using 5° BTDC as a reference point.

If the ignition timing is set to 10° BTDC with terminals TE₁ and E₁ shorted, the crankshaft angle will be 10° BTDC at the time of the next Ne signal after the G₁ (or G₂) signal.

This is known as the initial ignition timing.

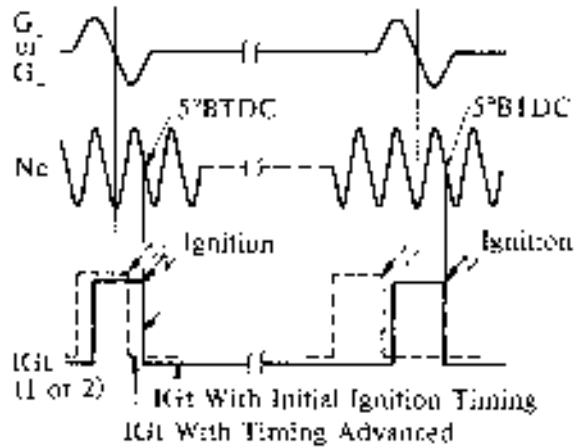

b. Calculating Ignition Timing

The ECU selects the basic ignition advance angle from the values stored in its memory based on the intake air volume and engine speed, then adds corrections based on signals from each sensor to determine the actual ignition timing.

$$\begin{aligned} \text{Ignition Timing} = & \text{Initial Ignition Timing} \\ & + \text{Basic Ignition Advance Angle} \\ & + \text{Corrective Ignition Advance (or Retard) Angle} \end{aligned}$$

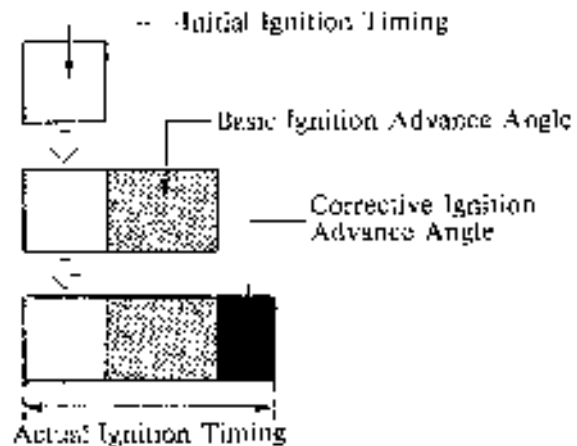

c. Igniter Control

The ECU sends an ignition timing signal (IGt_{1,2}) to the igniter based on signals from each sensor so as to achieve the optimum ignition timing. This ignition timing signal goes on just before the ignition timing calculated in the ECU, then the ignition timing signal goes off. The spark plug fires at the point when this signal goes off.

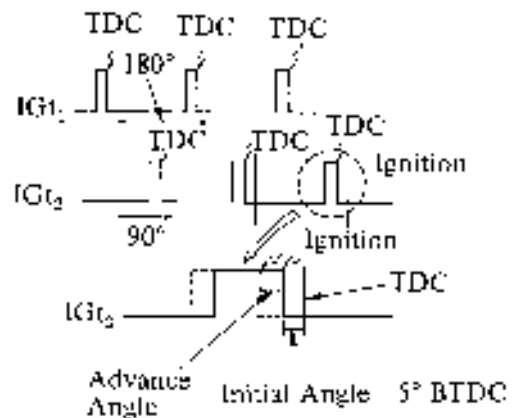

2) Ignition Timing Control

Ignition timing control consists of two basic elements: 1) Ignition control during starting (while the engine is cranking, ignition occurs at a certain fixed crankshaft angle, regardless of engine operating conditions); and 2) After-start ignition control, in which various corrections (made by the ECU based on signals from the relevant sensors) are added to the basic advance angle, which is determined by the intake air volume signal and the engine speed signal during normal operation.

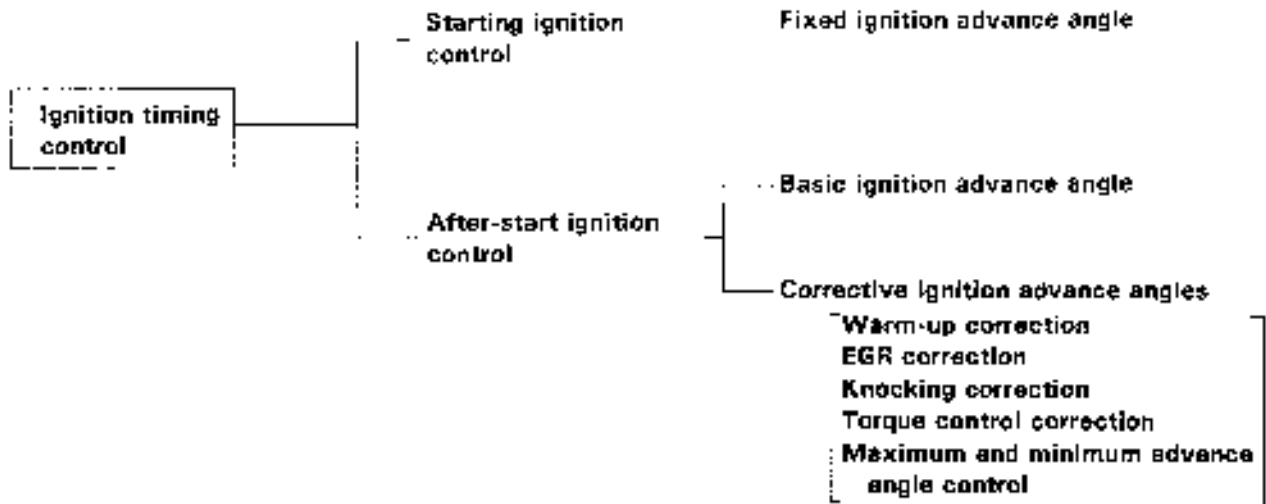

a. Starting Ignition Control

Since the engine speed is still below a specified rpm and unstable during and immediately after starting, the ECU cannot accurately determine the correct ignition timing. For this reason, the ignition timing is fixed at the initial ignition timing of 5° BTDC until engine operation is stabilized.

<p>RELEVANT SIGNALS</p> <ul style="list-style-type: none"> • Engine speed (Ne) • Ignition switch (STA)
<p>CONDITIONS</p> <p>Engine speed below specified rpm, or STA on.</p>

NOTE: At engine adjustment time, etc., with the vehicle stopped, confirm the ignition timing by connecting the TE1 and E1 terminals in the check connector or TDCL with the throttle valve fully closed.

Under the above conditions, ignition advance should not be occurring and the ignition timing should be the initial ignition timing (10° BTDC).

b. After-Start Ignition Control

i) Basic Ignition Advance Angle Control

This corresponds to the vacuum advance and governor advance angles in conventional type ignition system. The memory in the ECU contains optimum advance angle data for the intake air volume and the engine speed. The ECU selects the basic ignition advance angle from memory according to the engine speed signals from the engine speed sensor and the intake air volume signals from the air flow meter.

• **IDL Contacts Open (OFF)**

When the IDL contacts open, the ECU determines the basic ignition advance angle based upon data stored in the memory. This data can be shown in the form of a table, as shown in the chart.

<p>RELEVANT SIGNALS</p> <ul style="list-style-type: none"> • Air flow meter (Ks) • Engine speed (Ne) • Throttle position (IDL₁) • Intake air temperature (THA) • High altitude compensation (HAC)

• **Basic Ignition Advance Angle Data**

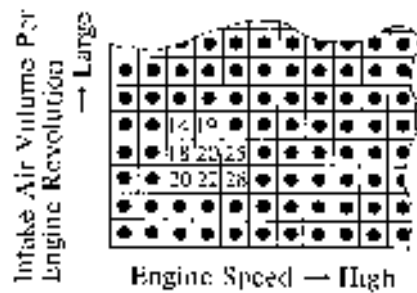

—REFERENCE—

Since the capacity of the ECU's memory is limited, it cannot hold all possible advance angle data. For this reason, the ECU selects the value that is the closest to the required value for each particular combination of engine speed and intake air volume. It then carries out proportional calculations to find the optimum ignition timing for the given engine speed and the intake air volume.

• **IDL Contacts Closed (ON)**

When the IDL contacts close, the ignition timing is advanced as shown, in accordance with the engine speed, whether the air conditioner is on or off, and whether neutral start switch is on or off.

<p>RELEVANT SIGNALS</p> <ul style="list-style-type: none"> • Throttle position (IDL₁) • A/C switch (A/C) • Engine speed (Ne) • Neutral start switch (NSW) • Vehicle speed (SP₁)
--

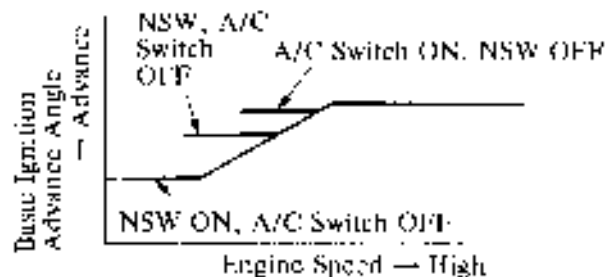

ii) Corrective Ignition Advance Angle Control**• Warm-Up Correction**

When the coolant temperature is low, the ignition timing is advanced according to it to improve drivability.

RELEVANT SIGNALS

- Coolant temperature (THW)
- Intake air volume (Ks)
- Engine speed (Ne)
- Intake air temperature (THA)
- High altitude compensation (HAC)

• EGR Correction

When the EGR is operating and the IDL contacts are turned off, the ignition timing is advanced according to the amount of intake air and the engine rpm to improve drivability.

RELEVANT SIGNALS

- Intake air volume (Ks)
- Engine speed (Ne)
- Intake air temperature (THA)
- Throttle position (IDL₁, V_{TA1}, V_{TA2})
- High altitude compensation (HAC)
- Coolant temperature (THW)
- Neutral start switch (NSW)
- Traction control (TRC)*

* Models with optional TRAC system

- **Knocking Correction**

The ignition timing at which engine knocking occurs differs according to the fuel octane value. The ECU controls the ignition timing at the optimum timing to correspond to the fuel octane value.

If engine knocking occurs, the knock sensor converts the vibration from the knocking into voltage signals and sends them to the ECU. The ECU judges whether the knocking strength is at one of three levels; strong, medium or weak, according to the strength of the knock signals and changes the corrective ignition retard angle. That is, if knocking is strong, the ignition timing is retarded a lot, and if it is weak, it is retarded a little.

When engine knocking stops, the ECU stops retarding the ignition timing and advances it by fixed angles a little at a time.

If ignition timing advance continues and engine knocking recurs, ignition timing is again retarded.

The ECU feeds back signals from the knock sensor to correct ignition timing as shown below.

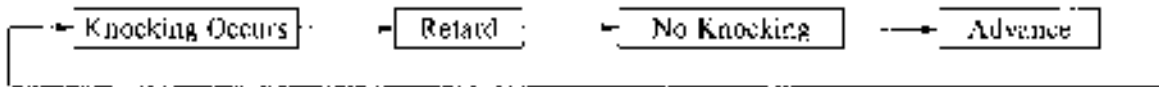

- * The knocking is judged for each cylinder at the time of ignition. But knocking correction is performed for all cylinders at one time.

RELEVANT SIGNALS

- Engine speed (Ne)
- Intake air volume (Ks)
- Coolant temperature (THW)
- Engine knocking (KNK₁) (KNK₂)

CONDITIONS

- Intake air volume per engine revolution is larger than a certain level.
- Ignition timing is not retarded at coolant temperature below 140°F (60°C).

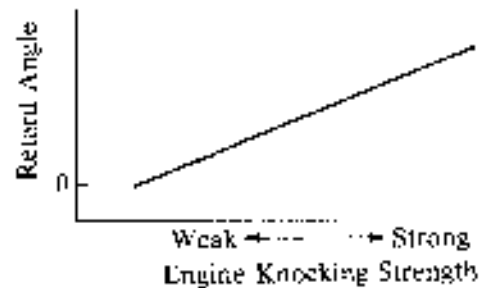

• Torque Control Correction

Each clutch and brake of the planetary gear unit in the transmission generates shock more or less during shifting. In the 1UZ-FE engine of the Lexus, this shock is minimized by momentarily retarding the ignition timing when gears are shifted up or down in the automatic transmission.

When the ECU judges a gear shift timing according to signals from various sensors, it activates the shift control solenoid valves to perform gear shifting. When the gear shifting starts, the ECU retards the engine ignition timing to reduce the engine torque.

As a result, engagement force of the clutches and brakes of the planetary gear unit is weakened and the gear shift change is performed smoothly.

RELEVANT SIGNALS

- Vehicle speed (SP₂)
- OD direct clutch speed (Nco)
- Throttle position (V_{TA})
- Gear shift position (S₁, S₂)
- Coolant temperature (THW)
- Battery voltage (+B)

iii) Maximum and Minimum Advance Angle Control

If the actual ignition timing (initial ignition timing + basic ignition advance angle + corrective ignition advance or retard angle) becomes abnormal, the engine will be adversely affected. To prevent this, the ECU controls the actual ignition timing so that the sum of the basic ignition and corrective ignition advance or retard angle cannot be greater or less than certain values.

Maximum advance angle: 55° BTDC

Minimum advance angle: 4° BTDC

3) Igniter Control

a. During Engine Starting and Immediately After Starting

During engine starting and immediately after starting, the ECU begins sending the IGt_{1, 2} signal to the igniter at 30° crankshaft angle before the initial ignition timing angle (5° BTDC).

CONDITION

- STA on or engine speed below 400 rpm.

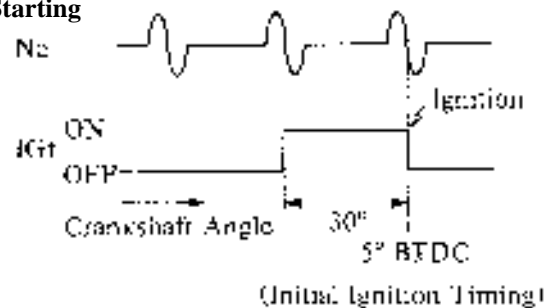

NOTE: The ignition timing is fixed at 10° BTDC when the IDL is on and the T_{E1} and E₁ terminals in the check connector or TDCL are connected.

b. During Engine Running

During engine running, the ECU begins sending the IGt_{1, 2} signal to the igniter at 30° crank angle before the ignition point that it has just calculated.

CONDITION

- Engine speed above 400 rpm.

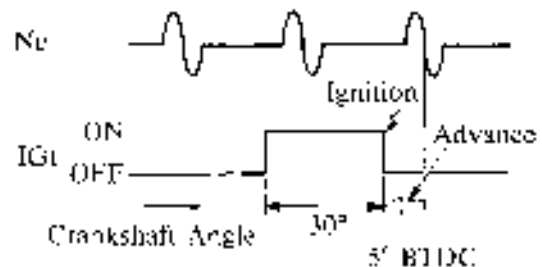

8. ISC (Idle Speed Control)

General

The step motor type ISC valve is used, which controls the idle speed at a target speed based on the signals from the ECU by adjusting the volume of air by passing the throttle valve. Also, when the engine is cold, the ISC valve is opened widely corresponding to the coolant temperature and the engine speed is increased, causing fast idle.

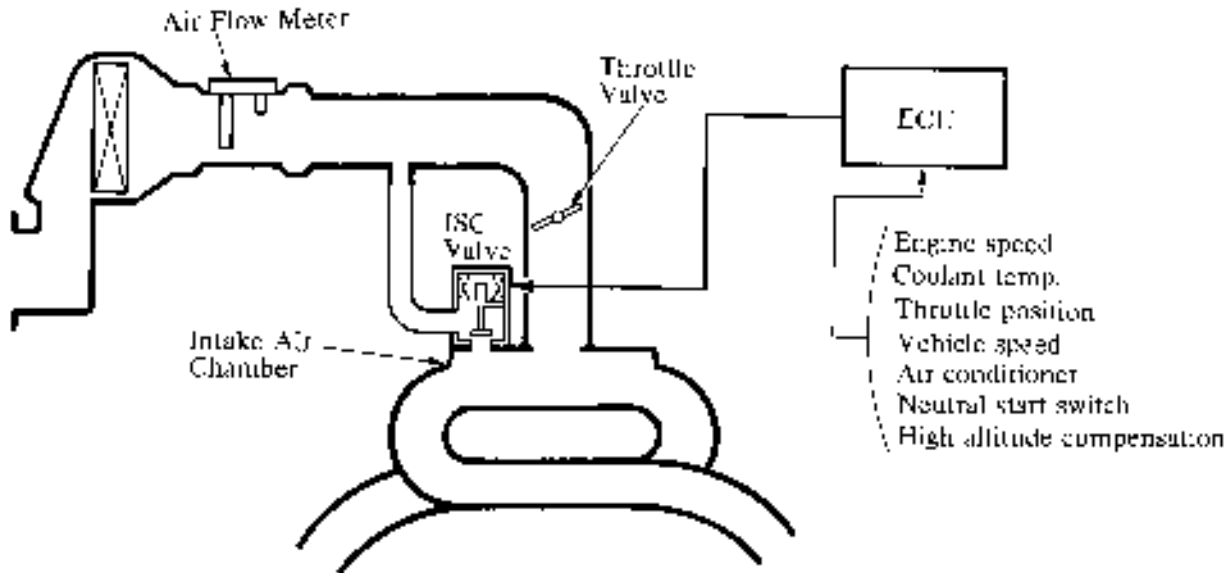

System Diagram

This type of ISC valve is connected to the ECU as shown in the following diagram. Target speeds for each coolant temperature, air conditioner operating state and neutral start switch signal are stored in the ECU's memory.

When the ECU judges from the throttle valve opening angle and vehicle speed signals that the engine is idling, it switches on Tr₁ to Tr₄ in order, in accordance with the output of those signals, sending current to the ISC valve coil, until the target speed is reached.

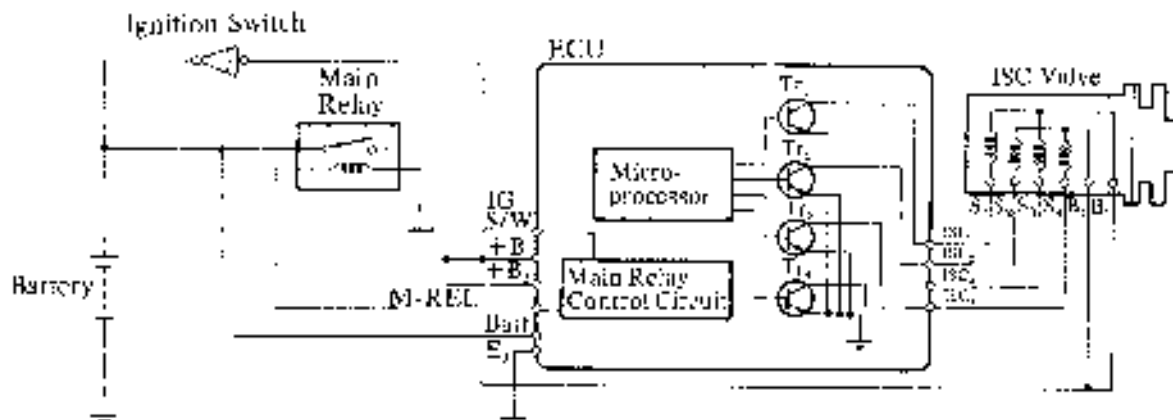

ISC Valve

The ISC valve is provided on the intake air chamber and intake air bypassing the throttle valve is directed to the ISC valve through a hose.

A step motor is built into the ISC valve. It consists of four coils, the magnetic rotor, valve shaft and valve.

When current flows to the coils due to signals from the ECU, the rotor turns and moves the valve shaft forward or backward, changing the clearance between the valve and the valve seat. In this way the intake air volume bypassing the throttle valve is regulated, controlling the engine speed.

There are 125 possible positions to which the valve can be opened.

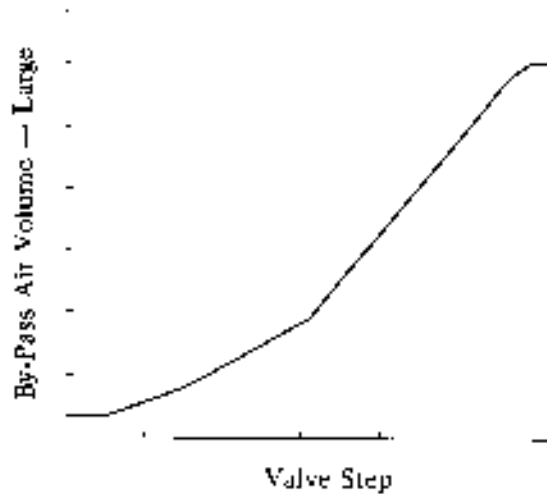
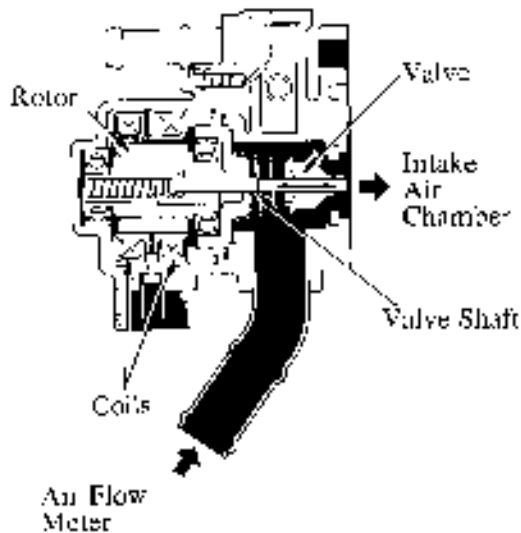

- Rotor—Constructed of a 16-pole permanent magnet.
- Stator—Two sets of 16-pole cores, each of which is staggered by half a pitch in relation to the other; two coils are wound around each core, each coil being wound in opposing directions.

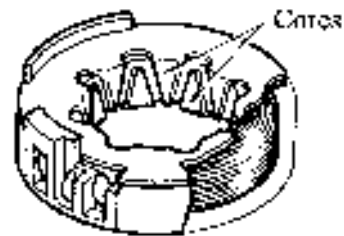

Movement of Valve

The valve shaft is screwed into the rotor. It is prevented from turning by means of a stopper plate so it moves in and out as the rotor rotates. This causes the distance between the valve and valve seat to decrease or increase, thus regulating the amount of air allowed through the bypass.

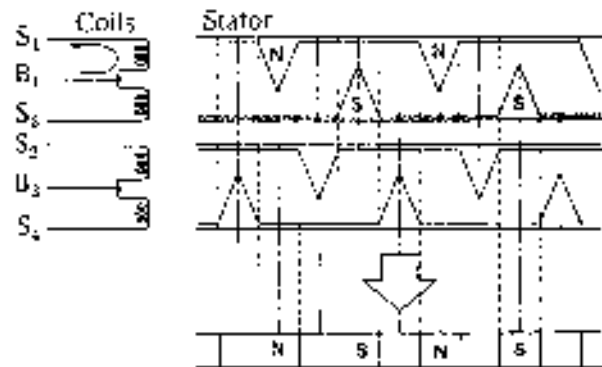

Rotation of Rotor

The direction of rotation of the motor is reversed by changing the order in which current is allowed to pass through the four coils. The rotor rotates about 11° (1/32 of a revolution) each time electric current passes through the coils.

When the rotor rotates one step, the positional relationship shown in the figure develops, and the stator coil is excited. Since the N poles tend to be attracted to the S poles in the stator and rotor, and since like poles in the stator and rotor tend to repel each other, the rotor moves one step.

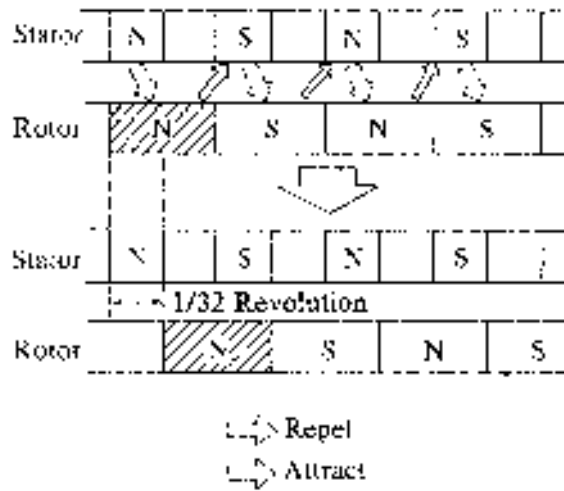

Function of ECU

1) Initial Set-Up

When the engine is stopped, the ISC valve is fully opened to the 125th step to improve startability when the engine is restarted.

RELEVANT SIGNAL	_____
• Engine speed (Ne)	

• Main Relay (ISC Valve Initial Set-Up) Control

The supply of power to the ECU and ISC valve must be continued, even after the ignition switch is turned off, in order to allow the ISC valve to be set-up (fully opened) for the next engine start-up.

Current to Main Relay	Conditions
ON	Ignition switch on
OFF	Ignition switch off, ISC valve set-up complete

Therefore, the ECU outputs 12V from the M-REL terminal until the ISC valve is set-up in order to keep the main relay on. Once set-up is complete, it cuts off the flow of current to the main relay coil.

2) After-Start Control

If the engine is started and the ISC valve were kept fully open, the engine speed will rise too high. Therefore, immediately after the engine is started, the ISC valve is adjusted to a position which corresponds to the coolant temperature. This makes the engine speed drop.

RELEVANT SIGNALS

- Engine speed (Ne)
- Coolant temperature (THW)
- Ignition switch (STA)
- Battery voltage (IGSW)
- Intake air temperature (THA)
- High altitude compensation (HAC)
- Neutral start switch (NSW)
- Air conditioner (A/C)

CONDITIONS

When the engine speed rises to a certain level. (The lower the coolant temperature, the higher this level becomes.)

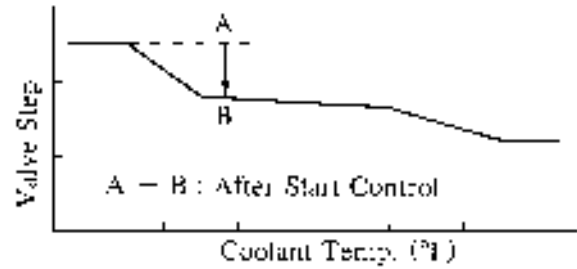

3) Warm-Up (Fast-Idle) Control

As the coolant warms up, ISC valve continues to gradually close from B to C.

When the coolant temperature reaches 158°F (70°C), fast-idle control by the ISC valve ends.

RELEVANT SIGNALS

- Engine speed (Ne)
- Coolant temperature (THW)
- Intake air temperature (THA)
- High altitude compensation (HAC)

CONDITIONS

Engine speed above 300 rpm.

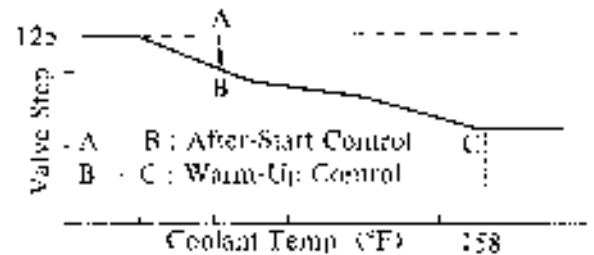

4) Feedback Control

If there is a difference between the actual engine speed and the target speed stored in the memory of the ECU, then the ECU sends a signal to the ISC valve and increases or decreases the volume of the air bypass so that the actual engine speed will match the target speed.

The target speeds differ depending on engine conditions such as neutral start switch on or off, and air conditioner switch on or off.

RELEVANT SIGNALS

- Throttle position (IDL₁)
- Vehicle speed (SP₁)
- Engine speed (Ne)
- Coolant temperature (THW)
- Intake air temperature (THA)
- Air conditioner (A/C)
- Neutral start switch (NSW)

CONDITIONS

IDL contacts close, vehicle speed is below a certain speed, engine speed is above 300 rpm and coolant temperature above 163.4°F (73°C).

• Target Idling Speed ◀

Air Conditioner Switch	Neutral Start Switch	Engine Speed
ON	ON	900 rpm
	OFF	750 rpm
OFF	ON	650 rpm
	OFF	580 rpm

5) Engine Speed Change Estimate Control

Immediately after the air conditioner switch or automatic transmission shift position is changed, the engine load also changes.

To prevent the engine speed from changing the ECU sends signals to the ISC valve to open or close it to a fixed amount before changes in the engine speed occur.

RELEVANT SIGNALS

- Engine speed (Ne)
- Air conditioner (A/C)
- Neutral start switch (NSW)
- Coolant temperature (THW)
- Vehicle speed (SP₁)

CONDITIONS

When air conditioner switch or neutral start switch is turned on or off with engine speed above 300 rpm.

9. EGR (Exhaust Gas Recirculation) Cut-Off Control

This system actuates the VSV (Vacuum Switching Valve) to cut the intake manifold vacuum acting on the EGR valve and thus shut off the EGR to maintain drivability.

1) Purpose of the EGR System

The EGR system is designed to recirculate the exhaust gas, properly controlled according to the driving condition, back into the intake air–fuel mixture. It helps to slow down combustion in the cylinder and thus lower the combustion temperature which, in turn, reduces the amount of NOx emission. The amount of EGR is regulated by the EGR vacuum modulator according to the engine load.

2) Operation of the EGR System

The exhaust gas pressure increases in proportion to the amount of intake air. As the throttle valve opens more and the amount of intake air increases, a higher exhaust gas pressure applies to the constant pressure chamber of the EGR valve. It pushes the diaphragm of the EGR vacuum modulator upward to narrow the “E” passage. Since intake vacuum acts then on E and R ports of the throttle body, the vacuum regulated by the “E” passage determined by the EGR vacuum modulator acts on the EGR vacuum chamber via the VSV. It opens the EGR valve which, in turn, leads exhaust gas into the intake air chamber. This also causes the gas pressure inside the constant pressure chamber to go down which, in turn, lowers the EGR vacuum modulator diaphragm.

The EGR valve is now under less vacuum and the valve moves until the vacuum balances with the spring tension. The amount of EGR gas is regulated as a result. As explained above, the EGR system controls the amount of EGR properly according to the exhaust gas pressure and the intake vacuum.

● EGR Operating (VSV OFF) ◀

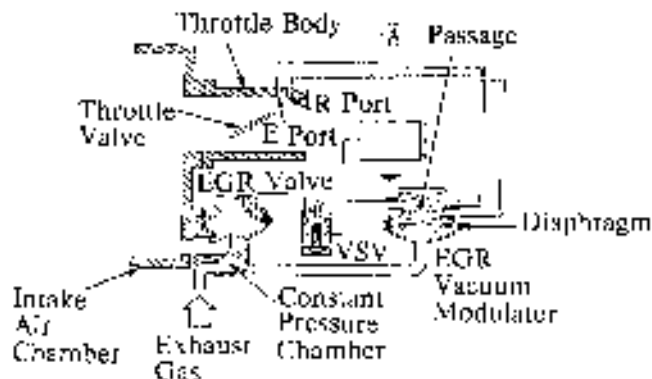

● EGR Cut-Off (VSV ON) ◀

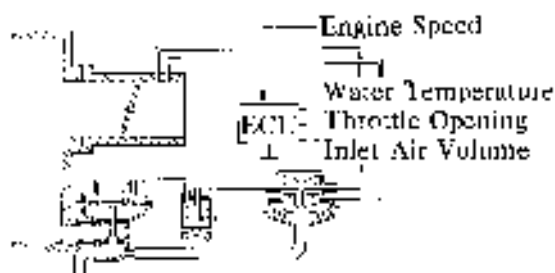

3) EGR Cut-Off Operation

When the VSV is turned on by a signal from the ECU, atmospheric air is led to the EGR valve, the EGR valve closes and shuts off the exhaust gas. This operation (EGR cut-off) is implemented when the following conditions exist:

- 1) Coolant temperature below 134.6°F (57°C)
- 2) During deceleration (throttle valve closed)
- 3) Light engine load (amount of intake air very small)
- 4) Engine speed over 4000 rpm
- 5) Engine racing (neutral start switch turned on)

10. Fuel Pump Speed Control

This control system increases the fuel pump output by switching the fuel pump speed to high if a large amount of fuel is required by the engine. In normal operations where the engine speeds are low, the fuel pump rotates at low speed to reduce unnecessary consumption of electric power and to maintain fuel pump durability.

Operation

1) During Engine Idling or Cruising

The ECU is constantly calculating the fuel injection duration per fixed period of time. When the engine is idling, or under normal driving conditions, that is, when the fuel injection duration per fixed period of time is shorter than the reference value, the ECU turns on the fuel pump control relay coil. When the control relay coil is turned on, the point contacts side B and the current to the fuel pump flows through a resistor, causing the fuel pump to run at low speed.

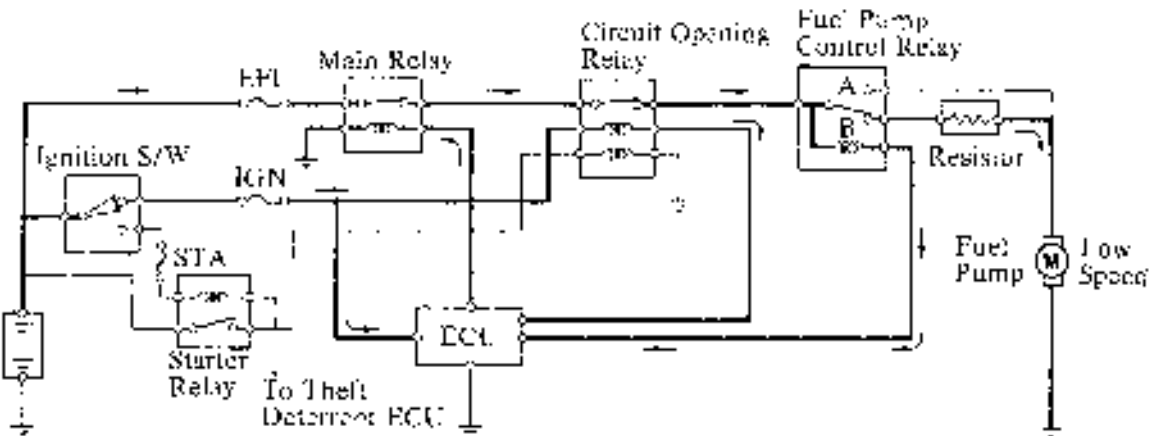

2) During High Engine Speed and High Load Operation

When the engine is operated at high speeds or under heavy loads, the fuel pump control relay coil is turned off. The point contacts with side A and the current to the fuel pump flows directly to the pump without passing through a resistor, causing the fuel pump to run at high speed.

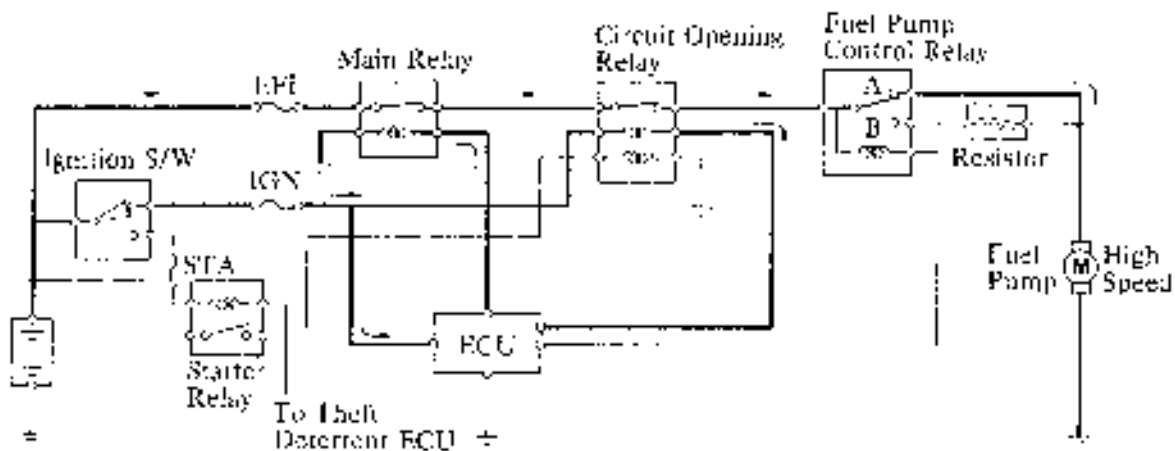

11. Fuel Pressure Control

When starting engine at high temperature, the ECU turns on a VSV to draw atmospheric pressure into the diaphragm chamber of the pressure regulator. Thereby, the fuel pressure is increased to prevent fuel vapor lock in order to help engine start.

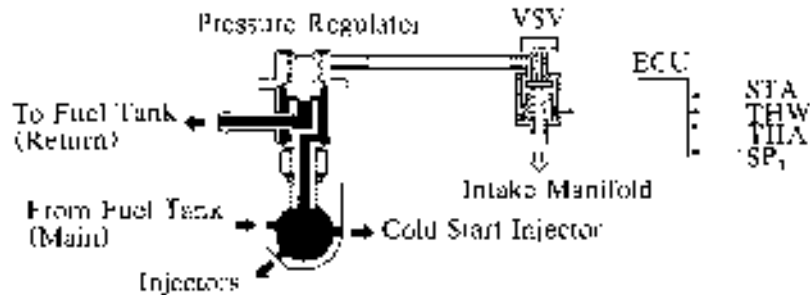

Operation

When the coolant temperature is 185°F (85°C) or higher and the intake air temperature is above a predetermined level, if the engine is cranked, the ECU turns on the VSV. As the VSV goes on, atmospheric air is introduced into the diaphragm chamber of the pressure regulator and the fuel pressure becomes higher by the amount of the intake manifold vacuum than the fuel pressure under normal engine operating conditions.

Even after the engine is started, the VSV remains on for about 100 seconds.

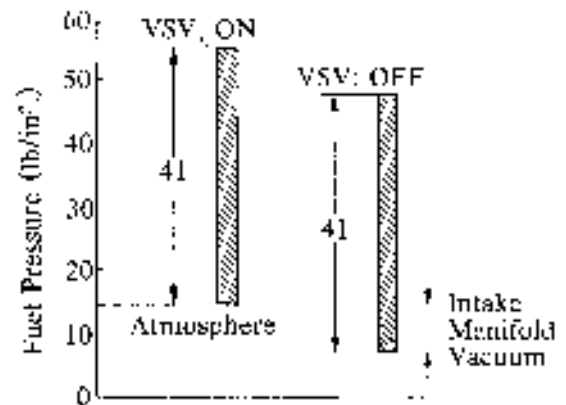

12. Oxygen Sensor Heater Control

The ECU controls the operation of the oxygen sensor heater according to intake air volume and engine speed. When the engine load is small and the exhaust gas temperature is low, the heater is operated to maintain sensor efficiency. Also, when the engine load becomes large and exhaust gas temperature becomes high, heater operation is stopped to prevent deterioration of the sensor.

This system controls both left and right banks simultaneously.

RELEVANT SIGNALS

- Coolant temperature (THW)
- Engine speed (Ne)
- Intake air volume (Ks)
- Intake air temperature (THA)
- Battery voltage (+B)
- High altitude compensation (HAC)

13. Air Conditioner Compressor Delay Control

When the air conditioner compressor is operated during idling, engine load fluctuates and the engine rpm drops momentarily. The delay control is designed to prevent the engine rpm drop.

Operation

When the ECU detects a signal (A/C) from the air conditioner ECU that the air conditioner switch is turned on, the ECU output a magnet clutch signal (ACMG) to the magnet clutch relay and turns it on.

The compressor magnetic clutch operation is delayed about 0.5 seconds after the air conditioner switch is turned on. During this time, the ECU opens ISC (Idle Speed Control) valve to offset the drop in the engine rpm due to the operation of the air conditioner compressor. This prevents the idle speed from dropping.

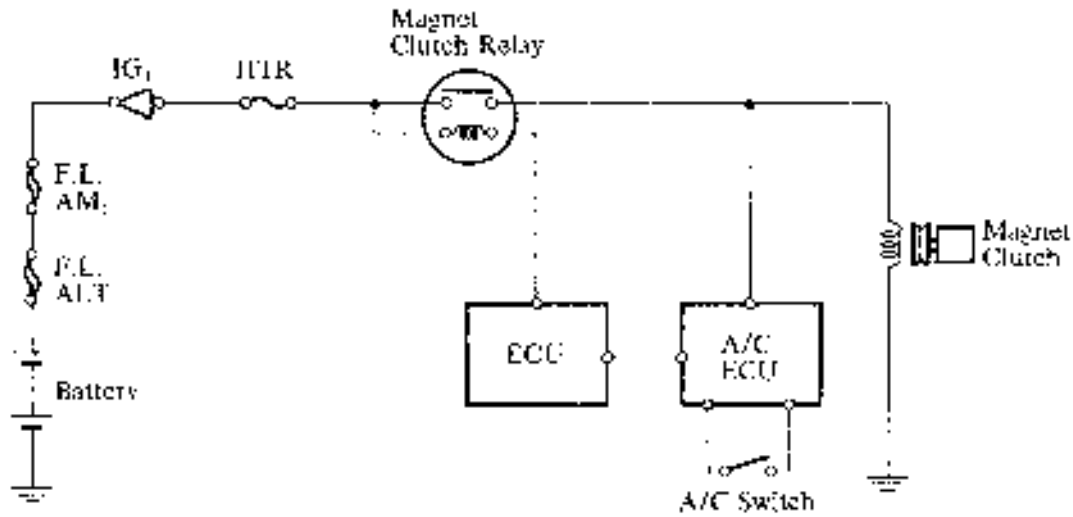

14. Diagnosis

General

The ECU contains a built-in self-diagnostic system. The ECU, which is constantly monitoring all sensors, and lights the "CHECK ENGINE" lamp when it detects a problem in the sensors or their circuitry. At the same time, the ECU registers the system containing the malfunction into its memory. This information is retained in memory even after the ignition switch is turned off, even after the malfunction has been corrected. When the vehicle is brought into the workshop for service because of the problem in the system, the contents of the memory may be checked to identify the malfunction.

After the problem is repaired, the diagnostic system is cleared by removing the EFI fuse for more than 10 seconds.

The contents of the diagnostic memory can be checked by connecting terminals in the check connector or in the TDCL and counting the number of times the CHECK ENGINE lamp blinks.

This self-diagnostic system has two types of malfunction detection mode; normal mode and test mode.

In the normal mode, it detects a malfunction if a problem, shown in the diagnostic items on page 154, occurs in the sensors or circuitry a specified number of times or continues for more than a specified period of time. The ECU lights the "CHECK ENGINE" lamp.

In the test mode, it has a more sensitive detection accuracy than the normal mode and detects a malfunction even if it occurs only once.

Thereby, it detects a poor contact between terminals of the connector or momentary disconnection of the wire, which is difficult to detect in the normal mode. The diagnostic items in the test mode are also shown on page 154.

“CHECK ENGINE” Lamp

1) Operation

- When the ignition switch is turned from OFF to ON, the “CHECK ENGINE” lamp goes on. After the engine is started, the lamp goes out. This is to inform the driver that the “CHECK ENGINE” lamp circuitry is operating normally.

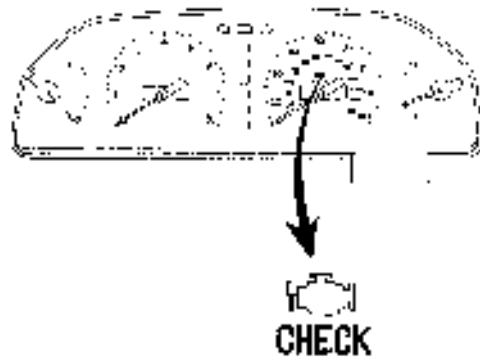

- The lamp lights immediately if a problem occurs in engine control system while the engine is operating (both in normal mode and test mode).
- If the problem is corrected, the lamp goes out five seconds after the problem has been corrected in the normal mode.
In the test mode, the lamp is kept lit until the ignition switch is turned off or T_{E1} and E₁ terminals are disconnected.
- In the normal mode, if the problem no longer exists at the time of repair (for example, if it is an intermittent problem), the “CHECK ENGINE” lamp will not light, even if the malfunction has been recorded in the memory of the ECU.

Diagnostic Mode and Output of “CHECK ENGINE” Lamp

The diagnostic mode (normal or test) and the output of the “CHECK ENGINE” lamp can be selected by changing the connections of the T_{E1}, T_{E2} and E₁ terminals in the TDCL (Total Diagnostic Communication Link) or check connector as shown in the table below.

T _{E1} and E ₁ Terminals	T _{E2} and E ₁ Terminals	Diagnostic Mode	Output of “CHECK ENGINE” Lamp
Open	Open	Normal	Warning to driver of malfunction.
	Connected	Normal	Output of diagnostic results (content of malfunction) in normal mode, indicated by number of times lamp blinks.
Connected	Open	Test	Warning to technician of malfunction.
	Connected	Test	Output of diagnostic results (content of malfunction) in test mode, indicated by number of times lamp blinks.

Diagnostic Procedure

1) Normal Mode

The diagnostic codes are displayed, by the procedure listed below, in order from the smallest to the largest code with the number of times the lamp blinks indicating the code number.

- ➡ Turn the ignition switch ON.
- ② Connect terminals T_{E1} and E₁.
- ③ IDL contacts ON (throttle valve fully closed).

• **TDCL** ◀

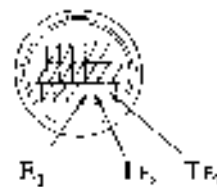

• **Check Connector** ◀

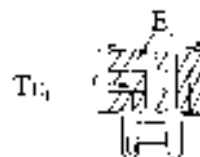

* Terminal T_{E2} is not provided in the check connector.

2) Test Mode

- ➡ First, connect terminals T_{E2} and E₁, then turn the ignition switch on to begin the diagnosis in the test mode.
- ② Start the engine.
- ③ Simulate the conditions of the malfunction described by the customer.
- ④ When a malfunction occurs and the “CHECK ENGINE” lamp lights up, terminals T_{E1} and E₁ should be connected for outputting the malfunction code. Lighting up of the “CHECK ENGINE” lamp and retention of the malfunction in the ECU memory continues until T_{E2} and E₁ terminals are disconnected or the ignition switch is turned to OFF.
- ⑤ End the test mode by disconnecting the terminals T_{E2} and E₁ or turn the ignition switch OFF.

NOTE: The test mode will not start if terminals T_{E2} and E₁ are connected after the ignition switch is turned on or terminals T_{E1} and E₁ are connected before the ignition switch is turned on.

Diagnostic Code Display

In both normal and test modes, the diagnostic results are displayed in two-digit codes.

1) Normal

The “CHECK ENGINE” lamp will blink about two times per second as shown in the chart.

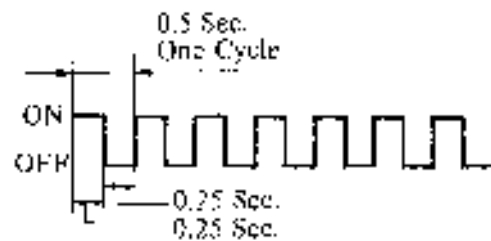

2) Malfunction

The appropriate diagnostic code(s) will be displayed.

In this case, codes 13 and 32 are indicated.

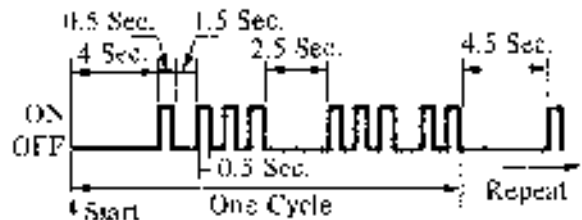

NOTE: If two or more malfunctions are present at the same time, the lowest-numbered diagnostic code will be displayed first.

Diagnostic Items

Code No.	Item	“CHECK ENGINE” Lamp*1		Diagnosis	Trouble Area	Memory*2
		Normal Mode	Test Mode			
12	RPM Signal	ON	N.A.	No “Ne” or “G” signal to ECU within 2 seconds after engine is cranked.	<ul style="list-style-type: none"> • Ne, G sensor circuit • Starter signal circuit • Ne, G sensor • ECU 	○
13	RPM Signal	ON	ON	<ul style="list-style-type: none"> • No “Ne” signal to ECU when the engine speed is above 1000 rpm. • The phase of the G₁ or G₂ signal and the Ne signal is shifted more than the standard value. 	<ul style="list-style-type: none"> • Ne sensor circuit • Ne sensor • ECU 	○
14*6	Ignition No. 1 Signal	ON	N.A.	No “IGf ₁ ” signal to ECU 8–11 times in succession.	<ul style="list-style-type: none"> • Igniter circuit • Igniter • ECU 	○
15*6	Ignition No. 2 Signal	ON	N.A.	No “IGf ₂ ” signal to ECU 8–11 times in succession.	<ul style="list-style-type: none"> • Igniter circuit • Igniter • ECU 	○
16	ECT Control Signal	ON	N.A.	ECT control program faulty.	<ul style="list-style-type: none"> • ECU 	X
17	Cam Position Sensor No. 1 Signal	N.A.	OFF	Open circuit in G ₁ sensor signal (G ₁).	<ul style="list-style-type: none"> • G₁ sensor circuit • G₁ sensor • ECU 	X
18	Cam Position Sensor No. 2 Signal	N.A.	OFF	Open circuit in G ₂ sensor signal (G ₂).	<ul style="list-style-type: none"> • G₂ sensor circuit • G₂ sensor • ECU 	X
21	Main Oxygen Sensor Signal (for left bank)	ON	ON	During air–fuel ratio feedback correction, output voltage of main oxygen sensor remains between 0.35V and 0.7V continuously for a certain period (OXL ₁).	<ul style="list-style-type: none"> • Main oxygen sensor circuit • Main oxygen sensor 	○
				Open circuit in oxygen sensor heater signal (HT ₁).	<ul style="list-style-type: none"> • Oxygen sensor heater circuit • Oxygen sensor heater • ECU 	○
22	Water Temp. Sensor Signal	ON	ON	Open or short circuit in water temp. sensor signal (THW).	<ul style="list-style-type: none"> • Water temp. sensor circuit • Water temp. sensor • ECU 	○
24	Intake Air Temp. Signal	ON*3	ON	Open or short circuit in intake air temp. sensor signal (THA).	<ul style="list-style-type: none"> • Intake air temp. sensor circuit • Intake air temp. sensor • ECU 	○
25*4	Air–Fuel Ratio Lean Malfunction	ON	ON	<ul style="list-style-type: none"> • When air–fuel ratio feedback correction value continues at the upper (lean) limit for a certain period of time or adaptive control value is not renewed for a certain period of time. • When air–fuel ratio feedback compensation value or adaptive control value feedback frequency is abnormally high during idle switch on and feedback condition. • When the difference of air–fuel ratio feedback compensation value between right and left banks is more than a certain percentage. 	<ul style="list-style-type: none"> • Injector circuit • Injector • Ignition system • Fuel line pressure • Oxygen sensor circuit • Oxygen sensor • Air flow meter • Water temp. sensor • ECU 	○
26*4	Air–Fuel Ratio Rich Malfunction				<ul style="list-style-type: none"> • Injector circuit • Injector • Fuel line pressure • Cold start injector • Air flow meter • Water temp. sensor • ECU 	
27	Sub–Oxygen Sensor Signal (for left bank)	ON	ON	Open circuit in sub–oxygen sensor signal (OXL ₂).	<ul style="list-style-type: none"> • Sub–oxygen sensor circuit • Sub–oxygen sensor • ECU 	○

Code No.	Item	“CHECK ENGINE” Lamp*1		Diagnosis	Trouble Area	Memory*2
		Normal Mode	Test Mode			
28	Main Oxygen Sensor Signal (for right bank)	ON	ON	During air–fuel ratio feedback correction, output voltage of main oxygen sensor remains between 0.35V and 0.7V continuously for a certain period (OXR ₁).	<ul style="list-style-type: none"> ● Main oxygen sensor circuit ● Main oxygen sensor 	○
				Open circuit in oxygen sensor heater signal (HT ₂).	<ul style="list-style-type: none"> ● Oxygen sensor heater circuit ● Oxygen sensor heater ● ECU 	○
29	Sub-Oxygen Sensor Signal (for right bank)	ON	ON	Open circuit in sub–oxygen sensor signal (OXR ₂).	<ul style="list-style-type: none"> ● Sub–oxygen sensor circuit ● Sub–oxygen sensor ● ECU 	○
31	Air Flow Meter Signal	ON	ON	No “Ks” signal to ECU when the engine speed is above 300 rpm.	<ul style="list-style-type: none"> ● Air flow meter circuit ● Air flow meter ● ECU 	○
35	HAC Sensor Signal	ON	ON	Open circuit in altitude HAC sensor signal.	<ul style="list-style-type: none"> ● ECU 	○
41	Throttle Position Sensor Signal	ON*3	ON	Open or short circuit in throttle position sensor signal (VTA ₁).	<ul style="list-style-type: none"> ● Throttle position sensor circuit ● Throttle position sensor ● ECU 	○
43	Starter Signal	N.A.	OFF	No “STA” signal to ECU until engine speed reaches 400 rpm with vehicle not moving.	<ul style="list-style-type: none"> ● Starter signal circuit ● Ignition switch, main relay circuit ● ECU 	X
47	Sub-Throttle Position Sensor Signal	ON*3	ON	Open or short circuit in throttle position sensor signal (VTA ₂).	<ul style="list-style-type: none"> ● Sub–throttle position sensor ● Sub–throttle position sensor circuit ● ECU 	○
52	Knock Sensor Signal 1	ON	N.A.	Open or short circuit in knock sensor signal (KNK ₁).	<ul style="list-style-type: none"> ● Knock sensor circuit ● Knock sensor ● ECU 	○
53	Knock Control Signal	ON	N.A.	Knock control program faulty.	<ul style="list-style-type: none"> ● ECU 	X
55	Knock Sensor Signal 2	ON	N.A.	Open or short circuit in knock sensor signal (KNK ₂).	<ul style="list-style-type: none"> ● Knock sensor circuit ● Knock sensor ● ECU 	○
71*5	EGR System Malfunction	ON	ON	EGR gas temp. below a predetermined level during EGR operation.	<ul style="list-style-type: none"> ● EGR system components ● EGR gas temp. sensor circuit ● EGR gas temp. sensor ● ECU 	○
51	Switch Condition Signal	N.A.	OFF	No “IDL” signal or No “NSW” signal or “A/C” signal to ECU during diagnosis check for test mode.	<ul style="list-style-type: none"> ● A/C amplifier ● A/C switch circuit ● Neutral start switch circuit ● Neutral start switch ● Throttle position sensor circuit ● Throttle position sensor ● Accelerator pedal and cable ● ECU 	X

*1: ON in the diagnostic mode column indicates that the “CHECK ENGINE” lamp will light up when a diagnosis is conducted and a malfunction is detected. OFF indicates that the lamp will not light even if a malfunction is detected during a diagnosis. N.A. indicates that diagnosis is not performed for that item.

*2: ○ mark in the memory column indicates that the code for a malfunction is stored in the ECU memory if that malfunction occurs once. X mark indicates that the code is not stored in the memory even if that malfunction occurs. For this reason, lamp indication of the malfunction code is limited to those times when the diagnostic results are output in accordance with the normal or test mode procedures.

*3: In the normal mode, when a malfunction occurs in code Nos. 24, 41 and 47, the “CHECK ENGINE” lamp will light up only in California specification vehicles.

*4: If the circuit of the main oxygen sensor is open or shorted in California specification vehicles, only code No. 25 is stored in the ECU memory. If malfunctions occur with items other than the main oxygen sensor, code Nos. 25 and 26 are stored simultaneously in memory for all items.

*5: Code No. 71 is used only for California specification vehicles.

*6: If diagnostic code “14” is displayed, check No. 1 igniter connected with harness wrapped with yellow tape. If diagnostic code “15” is displayed, check No. 2 igniter connected with harness not wrapped with yellow tape.

15. Fail-Safe

Fail-Safe Function

When a malfunction is detected by any of the sensors, there is a possibility of an engine or other malfunction occurring if the ECU were to continue to control the engine control system in the normal way. To prevent such a problem, the fail-safe function of the ECU either relies on the data stored in memory to allow the engine control system to continue operating, or stops the engine if a hazard is anticipated.

The following table describes the problems which can occur when trouble occurs in the various circuits, and the responses of the fail-safe function:

Circuit with Abnormal Signals	Necessity of Fail-Safe Function	Fail-Safe Function
Ignition Confirmation Signal (IGf _{1,2}) Circuit	If trouble occurs in the ignition system and ignition cannot take place (the ignition confirmation signal (IGf _{1,2}) is not input to the ECU), the catalyst could overheat due to misfiring.	Fuel injection is stopped.
<ul style="list-style-type: none"> Water Temp. Sensor Signal (THW) Circuit Intake Air Temp. Sensor Signal (THA) Circuit 	If an open or short circuit occurs in the water temperature or intake air temperature signal circuit, the ECU senses that the temperature is below -58°F (-50°C) or higher than 274.2°F (139°C). This results in the air-fuel ratio becoming too rich or too lean, which leads to engine stall or rough engine running.	Fixed values (standard values) are used, standard values are 176°F (80°C) for coolant temperature and 68°F (20°C) for intake air temperature.
Transmission Control Signal	If trouble occurs in the transmission control program in the ECU, transmission does not operate properly.	Torque control correction by the ESA is prohibited.
Air Flow Meter Signal (Ks) Circuit	If an open or short circuit occurs in the air flow meter signal circuit, it becomes impossible to detect the intake air volume and calculation if the basic injection duration cannot be done. This results in engine stalling or inability to start the engine.	Fixed (standard) values determined by the STA signal and IDL contacts conditions are used for the fuel injection duration and the ignition timing (10° BTDC), making engine operation possible.
High Altitude Compensation Sensor Signal (HAC) Circuit	If an open or short circuit occurs in the HAC sensor signal circuit, the atmospheric pressure corrective value is either the maximum or the minimum value. This causes the engine to run rough or reduces drivability.	A fixed value of 760 mmHg is used.
Main and Sub-Throttle Position Sensor Signal (VTA _{1,2}) Circuit	When an open or short circuit occurs in the throttle position sensor signal circuit, the ECU detects the throttle valve as being either fully open or fully closed to prevent engine stall.	A fixed value of 0° throttle valve opening angle is used.
<ul style="list-style-type: none"> Knock Sensor Signal (KNK_{1,2}) Circuit Knock Control System 	If an open or short circuit occurs in the knock signal circuit, or if trouble occurs in the knock control system inside the ECU, whether knocking occurs or not, ignition timing retard control will not be carried out by the knock control system, which could lead to damage to the engine.	The corrective retard angle value is set to the maximum value.

Back-Up Function

If there is trouble with the program in the ECU and the ignition signals (IGt) are not output, the ECU controls fuel injection and ignition timing at predetermined levels as a back-up function to make it possible to continue to operate the vehicle.

Furthermore, the injection duration is calculated from the starting signal (STA) and the throttle position signal (IDL). Also, the ignition timing is fixed at the initial ignition timing, 5° BTDC, without relation to the engine speed.

NOTE: If the engine is controlled by the back-up function, the “CHECK ENGINE” lamp lights up to warn the driver of the malfunction but the diagnostic code is not output.

● EMISSION CONTROL SYSTEM**1. System Purpose**

System	Abbreviation	Purpose
Positive crankcase ventilation	PCV	Reduces HC by eliminating blow-by gas
Exhaust gas recirculation	EGR	Reduces NO _x
Three-way catalyst	TWC	Reduces HC, CO and NO _x
Evaporative emission control	EVAP	Reduces evaporative HC
Air-fuel ratio feedback control	A/F	Reduces HC, CO and NO _x
Electronic fuel injection	EFI	Regulates all engine conditions for reduction of exhaust emissions.
High altitude compensator	HAC	Reduces HC and CO

2. Component Layout and Schematic Drawing

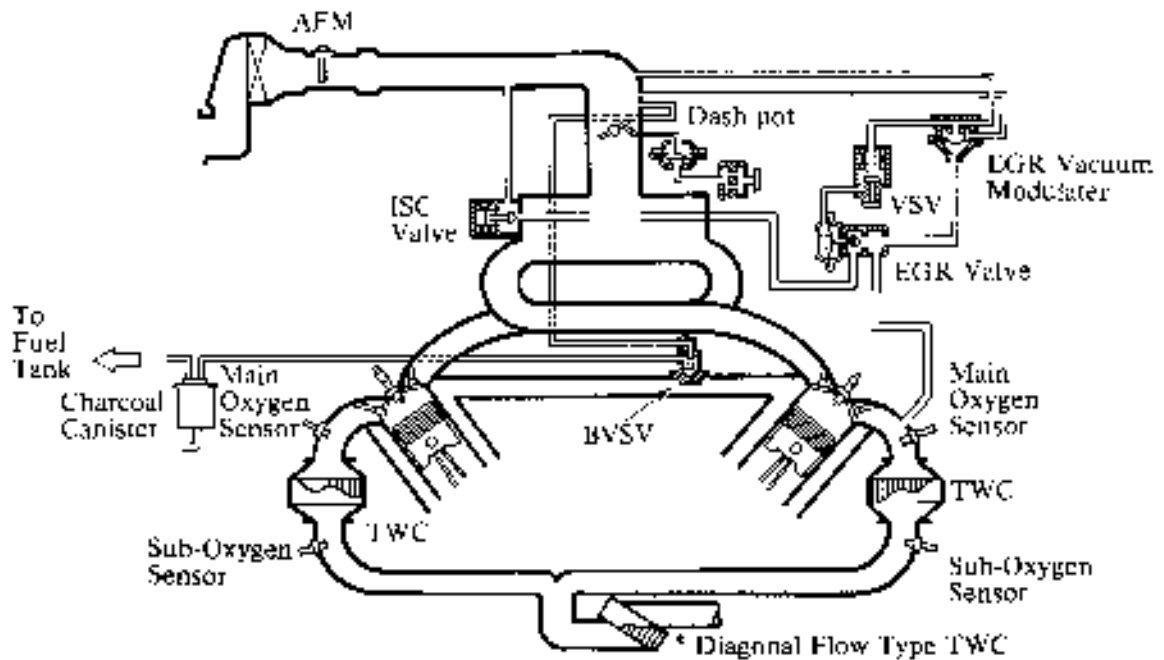
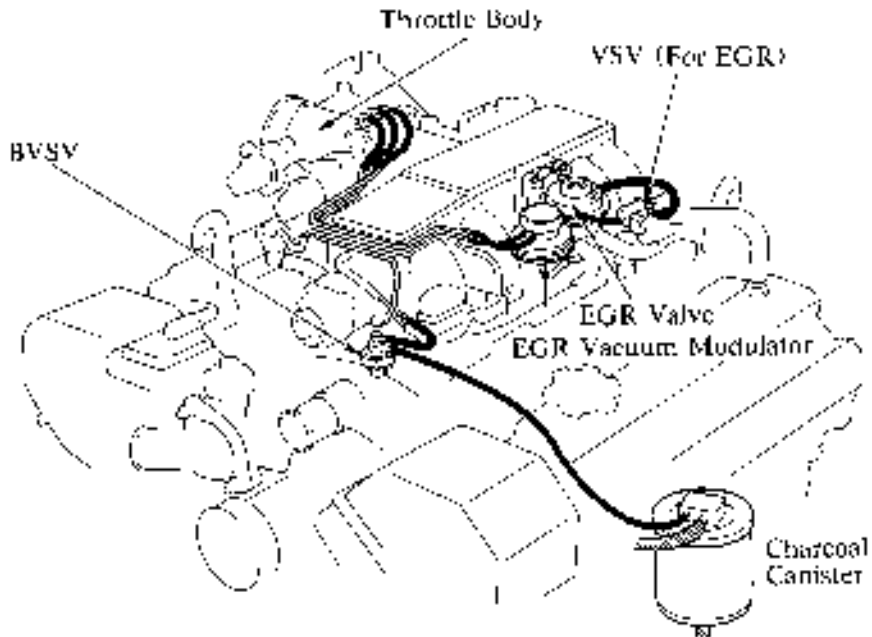

* Applicable only to the California specification vehicles.

3. Diagonal Flow Type Three-Way Catalyst (TWC)

A new type of high-performance catalyst converter developed by improving the shape and container construction is used.

It has monolithic catalysts and is diagonally arranged in relation to the flow of exhaust gas reducing the length and the exhaust resistance with wider cross section area.

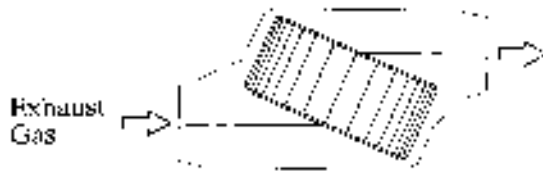

Diagonal Flow Type TWC

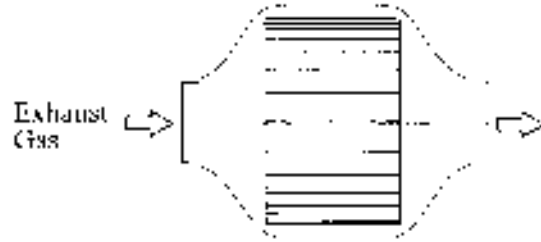

Conventional Type TWC

● 1UZ-FE ENGINE

1. General

The 1UZ-FE engine of the '93 LS400 differs from the '92 LS400 in the following areas:

System	Outline
Cooling System	A newly-developed aluminum radiator is lighter in weight.
Intake System	Throttle body is made both compact and light (together with the throttle position sensor and IAC* [ISC] valve).
Fuel System	<ul style="list-style-type: none"> • Fuel injectors are made more compact and light (total length shortened from 78.1 mm to 71 mm [3.07 in. —2.80 in.]). • Cold start injector has been discontinued.
Engine Control System	Refer to 2. Engine Control System table below.
Emission Control System	<ul style="list-style-type: none"> • EGR and EVAP systems are controlled by ECM [engine ECU]. • Secondary Air Injection system adopted for California-spec vehicles only.

* IAC (Idle Air Control)

2. Engine Control System

General

The following table shows the comparison of the engine control system of the '93 LS400's 1UZ-FE engine to that of the '92 LS400:

System	Outline	'93 LS400	'92 LS400
MFI* ¹ [EFI] See Page 29	<ul style="list-style-type: none"> • An L-type MFI [EFI] system directly detects the intake air volume with an optical Karman-Vortex type volume air flow meter. • The fuel injection system is a 4-group type and injects to 2 cylinders each. 	○	○
	When starting the engine, the fuel injection system sprays fuel into all cylinders at the same time.	○	—
Cold Start Injector Control	The injection duration of the cold start injector is controlled by the start injector time switch and ECM* ² [ECU].	—	○
ESA	Ignition timing is determined by the ECM* ² [ECU] based on signals from various sensors.	○	○
IAC* ³ [ISC]	A step motor type IAC [ISC] system controls the fast idle and idle speeds.	○	○

*¹: MFI (Multiport Fuel Injection)

*²: ECM (Engine Control Module)

*³: IAC (Idle Air Control)

System	Outline		'93 LS400	'92 LS400
Fuel Pump Control	Under light engine loads, pump speed is low to reduce electric power loss.	Uses a fuel pump relay and a fuel pump resistor.	—	○
		Uses fuel pump ECU (same as '92 SC400)	○	—
Fuel Pressure Control	In hot engine condition, the fuel pressure is increased to improve restartability.		○	○
Oxygen Sensor Heater Control	Maintain the temperature of the oxygen sensor at an appropriate level to increase accuracy of detection of the oxygen concentration in the exhaust gas.		○	○
Air Conditioning Cut-Off Control	By controlling the air conditioning compressor in accordance with the throttle valve opening angle and the vehicle speed, drivability is maintained.		○	○
EGR Control	Cuts off EGR according to the engine condition.		—	○
	Drives the EGR valve with step motor, controlling the EGR volume in accordance with the engine conditions. (same as '92 SC400)		○	—
Evaporative Emission Control	Controls the purge flow of evaporative emissions (HC) in the charcoal canister in accordance with engine conditions.	Controlled by TVV* ⁵ [BVSV] and VCV	—	○
		Controlled by ECM (same as '92 SC400)	○	—
Secondary Air Injection Control * ⁴ See Page 30	After starting a cold engine, an electric air pump delivers secondary air to the exhaust system to decrease emissions.		○	—
Diagnosis See Page 32	When the ECM detects a malfunction, the ECM diagnoses and memorizes the failed section.		○	○
Fail-Safe See Page 32	When the ECM detects a malfunction, the ECM stops or controls the engine according to the data already stored in memory.		○	○

*⁴ California specification vehicles only

*⁵ TVV (Thermal Vacuum Valve)

Construction

The configuration of the engine control system in the '93 LS400 is as shown in the following chart. Shaded portions differ from the '92 LS400.

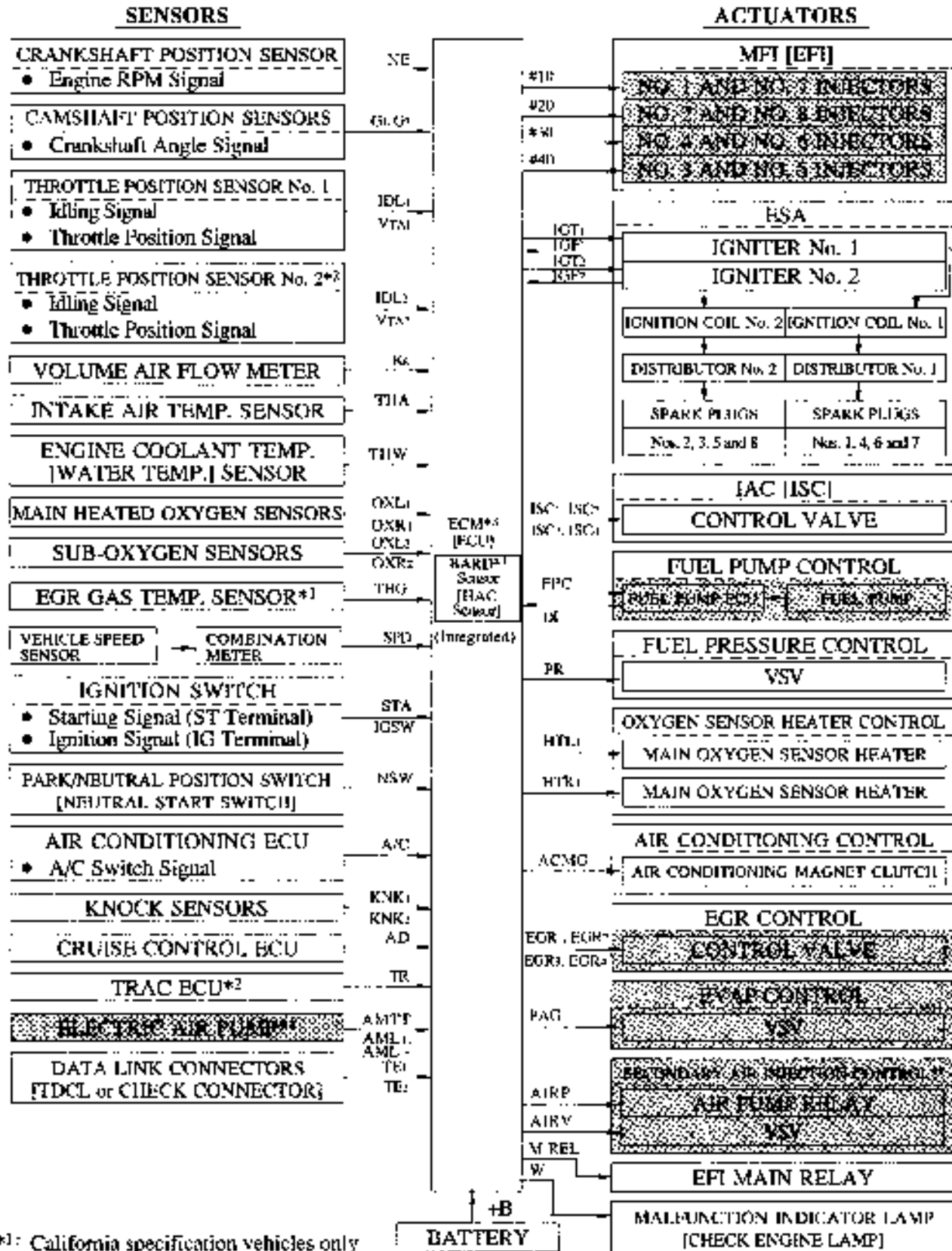

*1: California specification vehicles only

*2: Vehicles equipped with the optional TRAC (Traction Control) system

*3: ECM (Engine Control Module)

*4: BARO (Barometric Pressure)

MFI [EFI]

Along with the discontinuing of the cold start injector in the 1UZ-FE engine of the '93 LS400, the fuel injection system has been modified as follows, in the starting mode:

1UZ-FE Engine	'93 LS400	'92 LS400
Engine Condition		
Engine starting *1	Simultaneous injection to all cylinders (every 180°)	4-Group Type *2
Other than starting	4-Group Type	4-Group Type

*1 Engine speed below a predetermined.

*2 The cold start injector will also operate in accordance with the coolant temperature.

● **Fuel Injection Timing** ◀

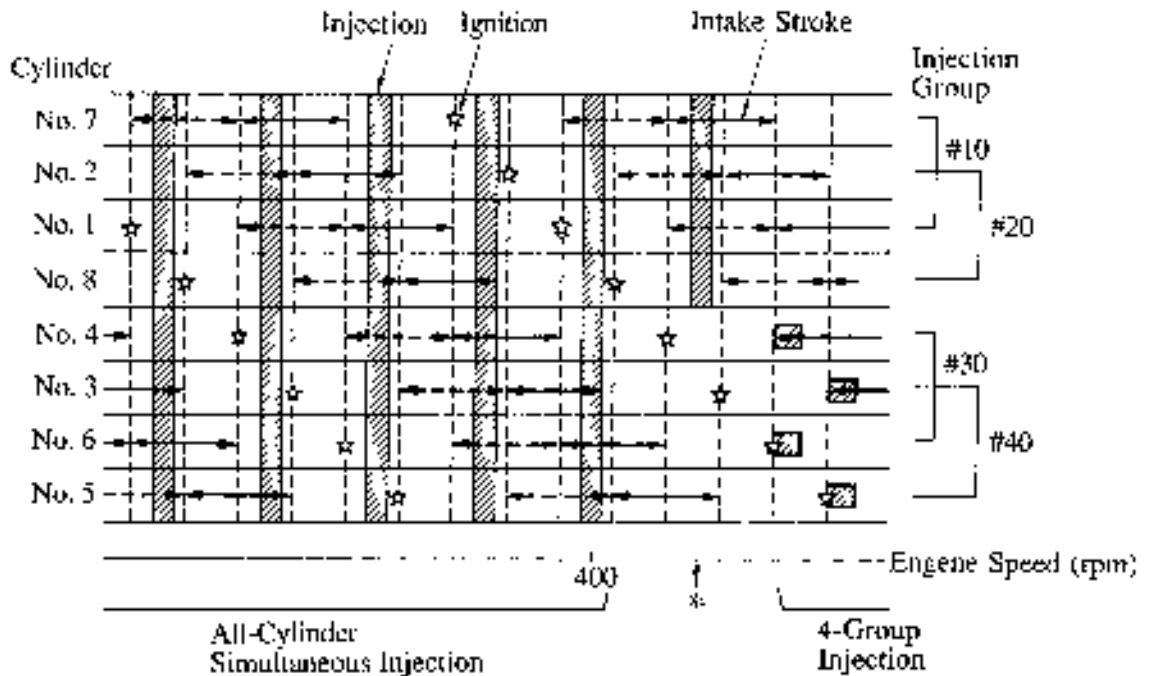

*: After #10, 20 (or #30, 40) group injection has been performed, the injection pattern will change from all-cylinders to 4-group injection.

Secondary Air Injection System (California specification vehicles only)

1) General

The Secondary Air Injection is part of the emission control system. It uses an electric air pump controlled by the ECM [engine ECU] to deliver air to the exhaust system. This will reduce through oxidation the CO and HC emitted by engine exhaust. Besides the ECM and air pump, this system is comprised of the VSV (Vacuum Switching Valve), ASV (Air Switching Valve), check valves, etc.

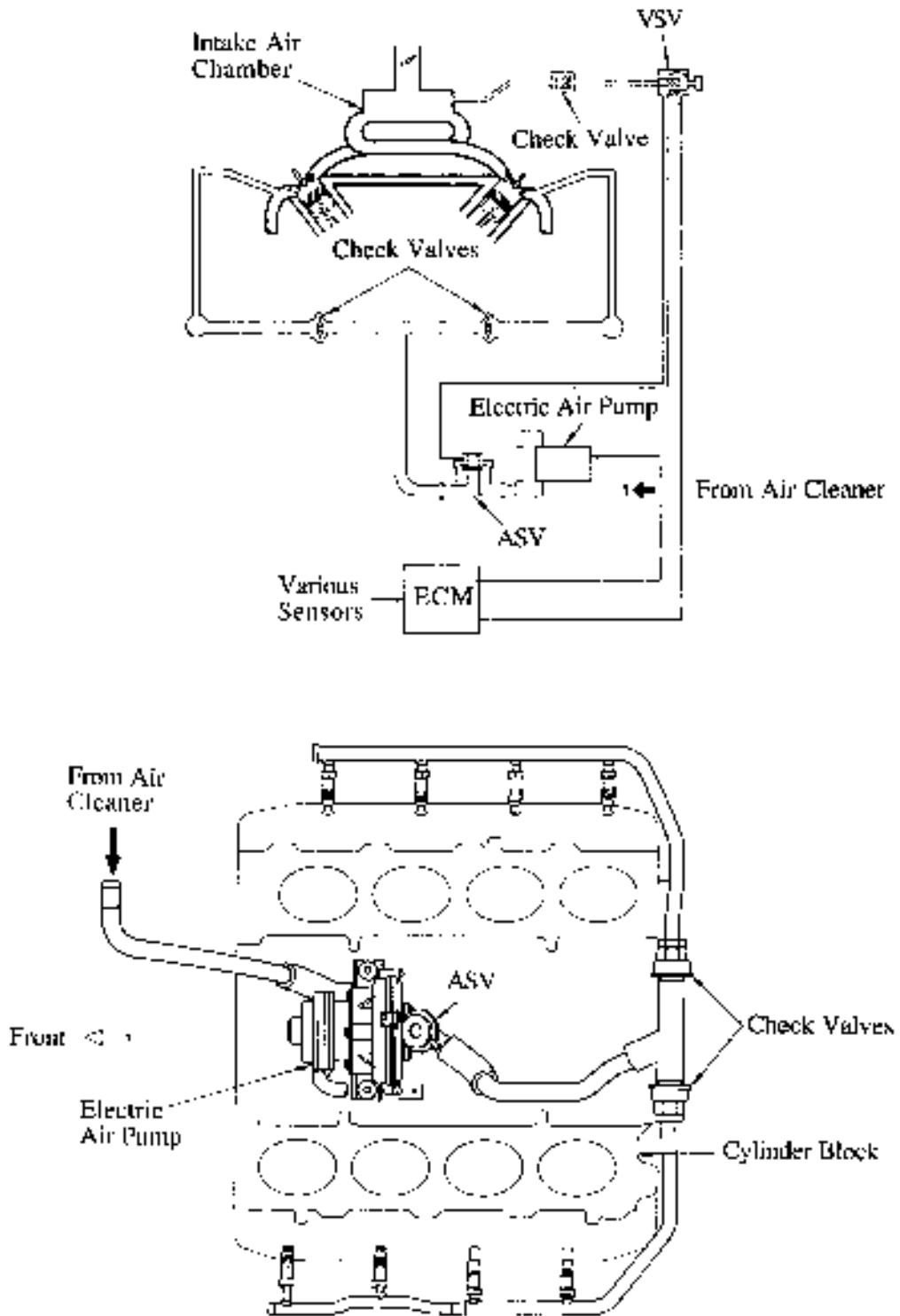

2) Construction

a. Electric Air Pump

The air pump is located on the v-bank of the cylinder block. It is a light and compact electric (DC motor) air pump which is controlled by the ECM [engine ECU].

The pressurized air from this pump is sprayed into the exhaust port after first passing through the ASV built in the pump. Provided that the VSV is on, the ASV will remain open by way of the stored intake manifold pressure.

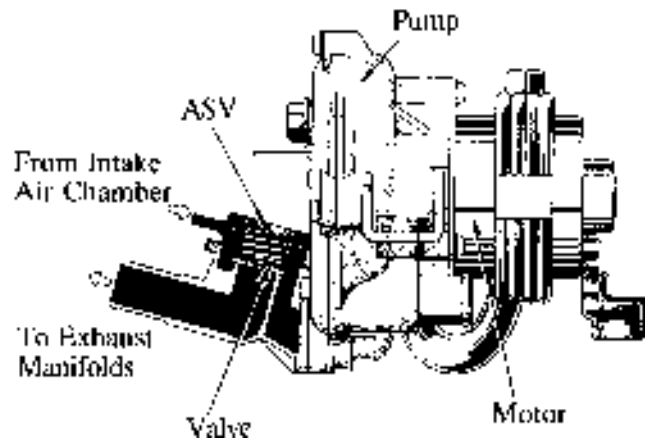

Electric Air Pump

3) Operation

After starting a cold engine, the ECM engages the air pump relay to run the air pump. At the same time, it engages the VSV. Therefore, the ASV opens under intake manifold pressure, allowing the secondary air injection to take place.

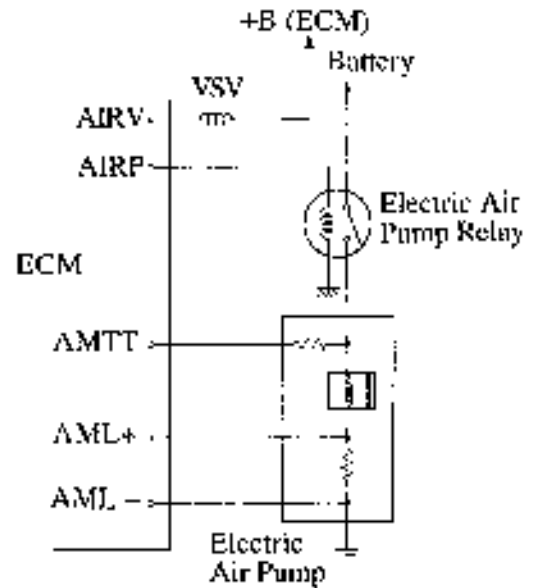

RELEVANT SIGNALS

- Engine speed (NE)
- Coolant temperature (THW)
- Volume Air flow meter (Ks)
- Intake air temperature (THA)
- Barometric pressure (HAC)

Diagnosis

The diagnostic system of the '93 LS400 has the following diagnostic trouble codes in addition to those in the '92 LS400. Code numbers 17 and 18 have been discontinued.

• Additional Diagnostic Trouble Codes ◀

Code No.	Item	Malfunction Indicator Lamp *1		Diagnosis	Memory *2
		Normal Mode	Test Mode		
42	Vehicle Speed Sensor Signal	OFF	ON	All conditions below are detected continuously for 8 sec. or more. (a) Vehicle speed signal: 0 km/h (mph) (b) Engine speed: 2800 rpm or more (c) Park/Neutral position switch [Neutral start switch]: OFF (d) Stop light switch : OFF	○
48*3	Secondary Air Injection System Malfunction	N.A.	N.A.	Open or short in VSV circuit of air switching valve for 5 sec. or more.	○
78	Fuel Pump Control Signal	OFF	ON	(1) Open or short in fuel pump circuit for 1 sec. or more with engine speed 1000 rpm or less. (2) Open in input circuit of fuel pump ECU (FPC) with engine speed 1000 rpm or less. (3) Open or short in diagnostic signal line (DI) of fuel pump ECU with engine speed 1000 rpm or less.	○

*1 : "ON" displayed in the diagnosis mode column indicates that the Malfunction Indicator Lamp [CHECK Engine Lamp] is lighted up when a malfunction is detected. "OFF" indicates that the "CHECK" does not light up during malfunction diagnosis, even if a malfunction is detected. "N.A." indicates that the item is not included in malfunction diagnosis.

*2 : "○" in the memory column indicates that a diagnostic trouble code is recorded in the ECM [engine ECU] memory when a malfunction occurs. "x" indicates that a diagnostic trouble code is not recorded in the ECM memory even if a malfunction occurs.

Accordingly, output of diagnostic results in normal or test mode is performed with the IG switch ON.

*3 : Only for California specification vehicles.

Fail-Safe

In addition to the '92 LS400 fail-safe functions, the '93 LS400 has added the electric air pump to the list of abnormal conditions to be detected.

1) In case of a malfunction in the electric air pump:

When the ECM [engine ECU] detects a problem in the electric air pump by way of the monitor terminals AMTT and AML+, it will disengage the air pump relay and VSV to stop the secondary air injection.

3. Emission Control System

General

The following is a comparison chart of the 1UZ-FE engine emission control system used in the '93 and '92 LS400 models:

System	Abbreviation	'93 LS400	'92 LS400
Positive crankcase ventilation	PCV	○	○
Evaporative emission control	EVAP	○*1	○
Exhaust gas recirculation	EGR	○*1	○
Three-way catalytic converter	TWC	○	○
Secondary air injection	AIR	○*1,*2	—
Multipoint fuel injection [Electronic fuel injection]	MFI [EFI]	○	○

*1 Controlled by ECM [engine ECU]. See page 26.

*2 California specification vehicles only.

Component Layout and Schematic Drawing

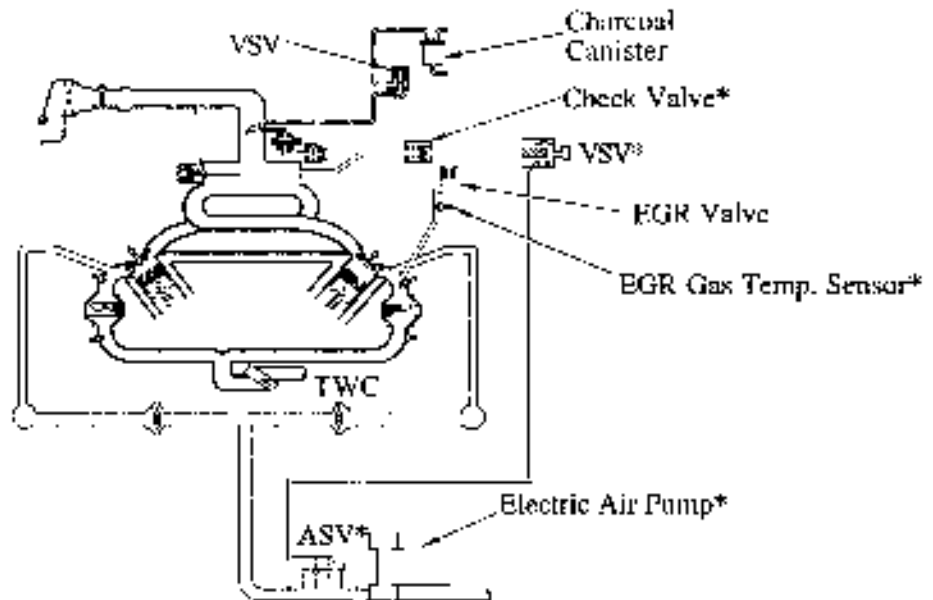
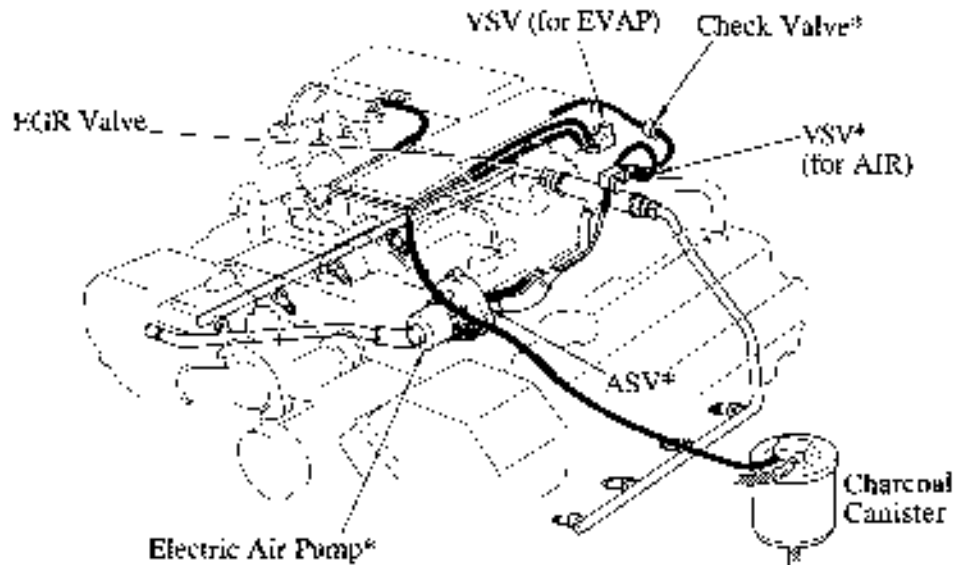

* California specification vehicles only.

● LS400

Item	Area	U.S.A.	Canada		
Body Type		4-Door Sedan	4-Door Sedan		
Vehicle Grade		—	—		
Model Code		UCF10L-AEPGKA	UCF10L-AEPGKK		
Major Dimensions & Vehicle Weights	Overall	Length mm (in.)	4995 (198.7)	←	
		Width mm (in.)	1830 (72.0)	←	
		Height mm (in.)	1415 (55.7)	←	
	Wheel Base	mm (in.)	2815 (110.8)	←	
	Thread	Front mm (in.)	1565 (61.6)	←	
		Rear mm (in.)	1565 (61.6)	←	
	Effective Head Room	Front mm (in.)	980 (38.6), 955 (37.6)*2	←	
		Rear mm (in.)	935 (36.8), 907 (35.6)*2	←	
	Effective Leg Room	Front mm (in.)	1113 (48.8)	←	
		Rear mm (in.)	872 (34.3)	←	
	Shoulder Room	Front mm (in.)	1451 (57.1)	←	
		Rear mm (in.)	1430 (56.3)	←	
	Overhang	Front mm (in.)	925 (36.4)	←	
		Rear mm (in.)	1255 (49.4)	←	
	Min. Running Ground Clearance	mm (in.)	160 (6.3)	←	
	Angle of Approach	degrees	17, 18 *1	17	
	Angle of Departure	degrees	16, 15*1	16	
	Curb Weight	Front kg (lb)	950 (2095)	970 (2140)	
		Rear kg (lb)	800 (1765)	810 (1785)	
		Total kg (lb)	1750 (3860)	1780 (3925)	
Gross Vehicle Weight	Front kg (lb)	1075 (2370)	←		
	Rear kg (lb)	1165 (2570)	←		
	Total kg (lb)	2240 (4940)	←		
Fuel Tank Capacity	L (U.S. gal, imp. gal)	85 (22.5, 18.7)	←		
Luggage Compartment Capacity	m ³ (cu.ft)	0.380 (13.42)	←		
Performance	Max. Speed	km/h (mph)	240 (149)	←	
	Max. Cruising Speed	km/h (mph)	215 (134)	←	
	Acceleration	0 to 100 km/h sec.	7.9	←	
		0 to 400 m sec.	15.8	←	
	Max. Permissible Speed	1st Gear km/h (mph)	82 (48)	←	
		2nd Gear km/h (mph)	130 (80)	←	
		3rd Gear km/h (mph)	—	—	
		4th Gear km/h (mph)	—	—	
Turning Diameter (Outside Front)	Wall to Wall m (ft.)	12.0 (39.4)	←		
	Curb to Curb m (ft.)	11.0 (36.1)	←		
Engine	Engine Type		1UZ-FE	←	
	Valve Mechanism		32-Valve, DOHC	←	
	Bore x Stroke	mm (in.)	87.5 x 82.5 (3.44 x 3.25)	←	
	Displacement	cm ³ (cu.in.)	3969 (242.2)	←	
	Compression		10.0: 1	←	
	Carburetor Type		MFI [EFI]	←	
	Research Octane No.	RON	96	←	
Max Output (SAE-NET)	kW/rpm (HP @ rpm)	186/5600 (250 @ 5600)	←		
Max Torque (SAE-NET)	N·m/rpm (lb-ft @ rpm)	353/4400 (260 @ 4400)	←		
Engine Electrical	Battery Capacity (20HR)	Voltage & Amp. hr.	12-64	←	
	Generator Output	Watts	1200	←	
	Starter Output	kW	2.0	←	
Chassis	Clutch Type		—	←	
	Transmission Type		A341E	←	
	Transmission Gear Ratio	In First		2.531	←
		In Second		1.531	←
		In Third		1.000	←
		In Fourth		0.705	←
		In Fifth		—	—
		In Reverse		1.880	←
	Differential Gear Ratio		3.615	←	
	Differential Gear Size	in.	8"	←	
	Brake Type	Front		Ventilated Disc	←
		Rear		Ventilated Disc	←
	Parking Brake Type		Duo Servo	←	
	Brake Booster Type and Size	in.	Tandem 8" + 9"	←	
	Proportioning Valve Type		P & B Valve	←	
Suspension Type	Front		Double Wishbone	←	
	Rear		Double Wishbone	←	
Stabilizer Bar	Front		STD	←	
	Rear		STD	←	
Steering Gear Type		Rack & Pinion	←		
Steering Gear Ratio (Overall)		18. : 1	←		
Power Steering Type		Integral Type	←		

*1: With Air Suspension, *2: With Moon Roof

ENGINE

1UZ-FE ENGINE

● DESCRIPTION

The 1UZ-FE engine in the '95 LS400 is a V8, 4.0-liter, 32-valve DOHC engine. Its construction and operation are basically the same as those of the previous models. However, improvements made to the various areas of the engine result in a lightweight and low-friction engine which provides both high power output and low fuel consumption as well as reduced noise and vibration for an even quieter operation. The diagnosis system of this engine conforms to the OBD-II requirements.

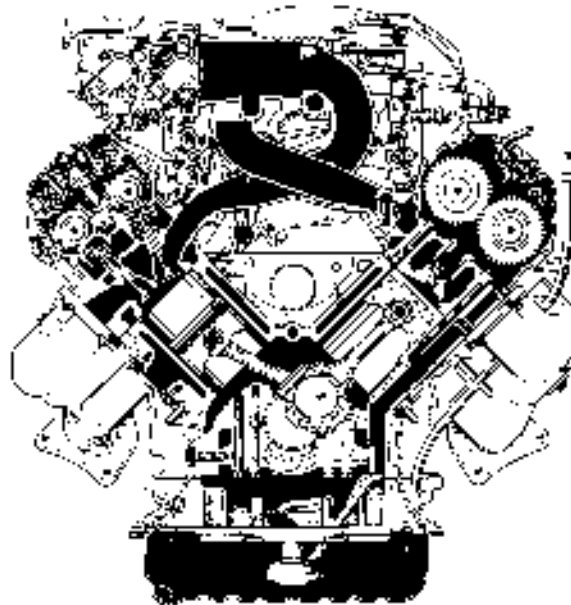
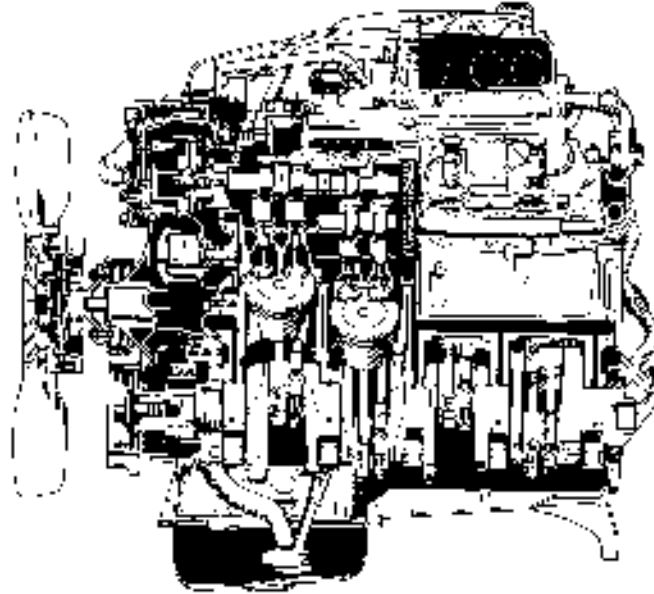

● ENGINE SPECIFICATIONS AND PERFORMANCE CURVE

1UZ-FE Engine		New	Previous	
Item				
No. of Cyls. & Arrangement		8-Cylinder, V Type	←	
Valve Mechanism		32-Valve DOHC, Belt & Gear Drive	←	
Combustion Chamber		Pentroof Type	←	
Manifolds		Cross-Flow	←	
Fuel System		SFI* ¹ [EFI]	MFI* ² [EFI]	
Displacement	cm ³ (cu. in.)	3969 (242.1)	←	
Bore x Stroke	mm (in.)	87.5 x 82.5 (3.44 x 3.25)	←	
Compression Ratio		10.4 : 1	10.0 : 1	
Max. Output [SAE-NET]		194 kW @ 5300 rpm (260 HP @ 5300 rpm)	186 kW @ 5600 rpm (250 HP @ 5600 rpm)	
Max. Torque [SAE-NET]		366 N·m @ 4500 rpm (270 ft·lbf @ 4500 rpm)	353 N·m @ 4400 rpm (260 ft·lbf @ 4400 rpm)	
Valve Timing	IN.	Open	6° BTDC	3° BTDC
		Close	46° ABDC	41° ABDC
	EX.	Open	46° BBDC	←
		Close	3° ATDC	←
Fuel Octane Number (RON)		96	←	
Oil Grade		API SH, EC-II, ILSAC* ³ or Better	API SG, SH, EC-II, ILSAC* ³ or Better	

*1: SFI (Sequential Multiport Fuel Injection) *2: MFI (Multiport Fuel Injection)

*3: ILSAC (International Lubricant Standardization and Approval Committee)

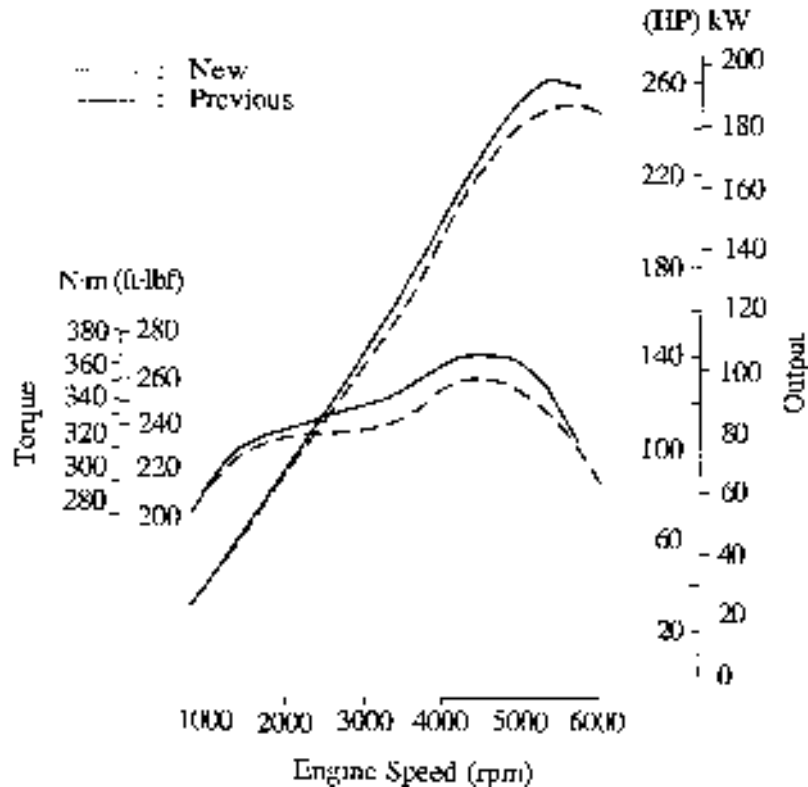

● MAJOR DIFFERENCES

The following changes have been made to the 1UZ-FE engine.

Item	Features
Engine Proper	<ul style="list-style-type: none"> • The water jacket configuration in the cylinder head is modified to improve the cooling performance in the area surrounding the combustion chamber in order to increase the engine's anti-knocking performance. • Passage holes are provided in the crankcase of the cylinder block to reduce pumping loss. • The shape of the piston is modified to produce a lightweight and low-friction piston. At the same time, the piston rings are given less tension to reduce friction loss. • The piston pin, connecting rod, and crankshaft are made lightweight to reduce the noise and vibration.
Valve Mechanism	<ul style="list-style-type: none"> • The valve timing and the amount of valve lift of the intake valve are modified. • The valve spring is given less tension to reduce friction loss. • The crankshaft timing pulley and camshaft timing pulleys are made more lightweight.
Lubrication System	<ul style="list-style-type: none"> • In addition to making the inlet of the oil strainer more compact and lightweight, a lower plate is provided to minimize the amount of air from being drawn in. • An aluminum alloy gasket is used on the oil drain plug of the oil pan.
Cooling System	<ul style="list-style-type: none"> • The number of water pump rotor blades is increased from 7 to 12.
Intake and Exhaust System	<ul style="list-style-type: none"> • The exhaust manifold is changed from the single type to the semi-dual type to improve exhaust efficiency. • The method for joining exhaust pipes together is changed from the flange type to the clamp type.
Engine Mounting	<ul style="list-style-type: none"> • The low-frequency damping coefficient of the liquid-filled compound engine mount is modified to further improve its quietness during idle. • The material of the engine rear mounting bracket is changed to aluminum alloy for weight reduction as well as for reducing the noise and vibration.
Starting System	<ul style="list-style-type: none"> • A compact and lightweight starter with higher torque is used to improve the engine's startability.
Engine Control System	<ul style="list-style-type: none"> • The hot-wire type mass air flow meter improves the accuracy of the intake air volume measurement. • A sequential multiport fuel injection system improves the engine response and reduces exhaust emissions. • The diagnosis system conforms to OBD-II.
Emission Control System	<ul style="list-style-type: none"> • An EGR gas cooler is adopted in the EGR system to improve the engine's anti-knocking performance. • The charcoal canister, a component of the evaporative emission control system, is made larger to improve its HC absorption rate and efficiency.* • A TWC (Three-Way Catalytic Converter) located under the floor has been adopted on all models.

*: California Specification models only.

● ENGINE PROPER

1. Cylinder Block

Passage holes [31 mm (1.22 in.) in diameter] are provided in the crankshaft bearing area of the cylinder block. As a result, the air at the bottom of the cylinder flows smoother, and pumping loss (back pressure at the bottom of the piston generated by the piston's reciprocal movement) is reduced to improve the engine's output.

● Air Flow During Engine Revolution ◀

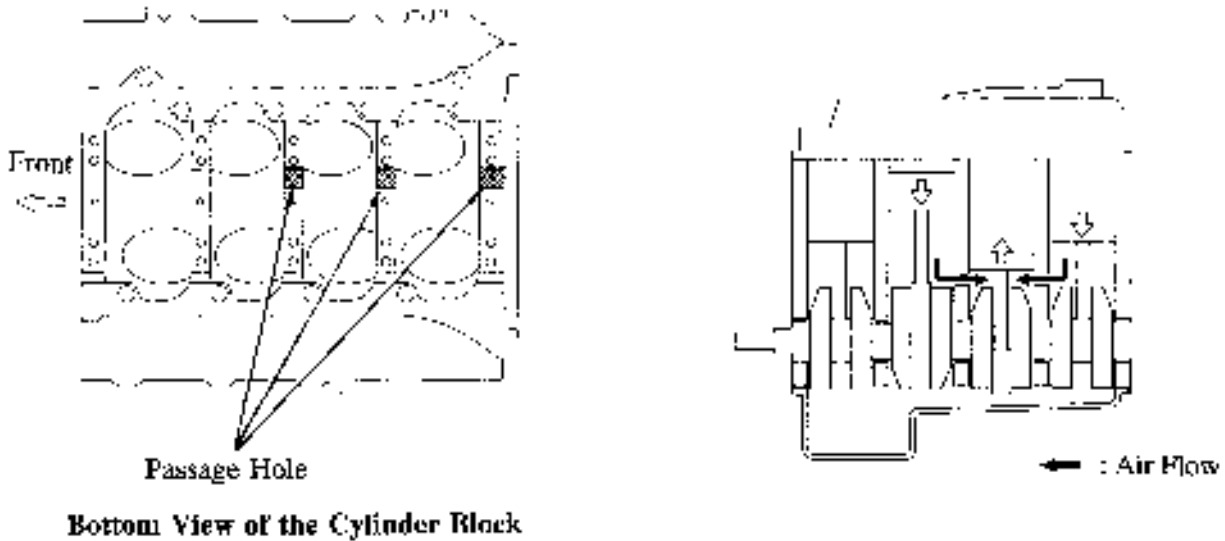

2. Piston

- The piston skirt area is made more compact and lightweight, resulting in reduced friction loss. At the same time, the skirt rigidity is improved to reduce the noise and vibration.
- The steel strut is discontinued for weight reduction.
- The oil return hole in the oil ring groove is changed from the slot type to slotless type.
- The piston rings are given less tension to reduce friction loss.
- The piston pin is made shorter and thinner for weight reduction. As a result, noise and vibration are reduced.

● Piston ◀

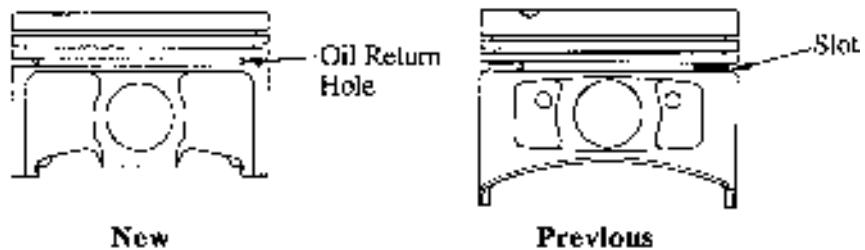

● Piston Pin ◀

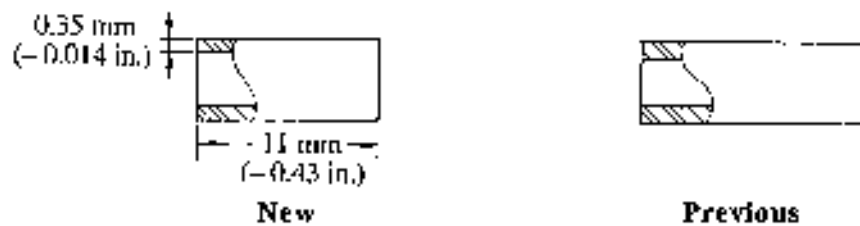

● INTAKE AND EXHAUST SYSTEM

1. Exhaust Manifold

The change from the previous single type to the semi-dual type provides a smoother exhaust gas flow. Accordingly, the engine performance has been improved by reducing exhaust gas interference during low- and mid-range operation, and reducing exhaust back pressure during high-speed operation.

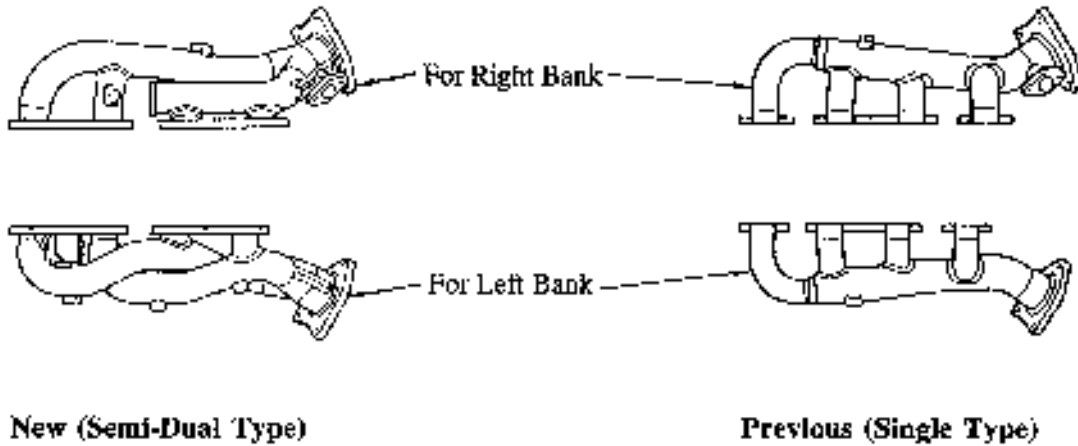

2. Exhaust Pipe

- The capacity of the sub-mufflers is increased (7.5 L x 2 → 8.8 L x 2).
- The method for joining exhaust pipes (Fig. 3) below) is changed from the flange type to the clamp type.
- The tail pipe opening is directed downward to reduce soiling of the bumper by the exhaust gas.

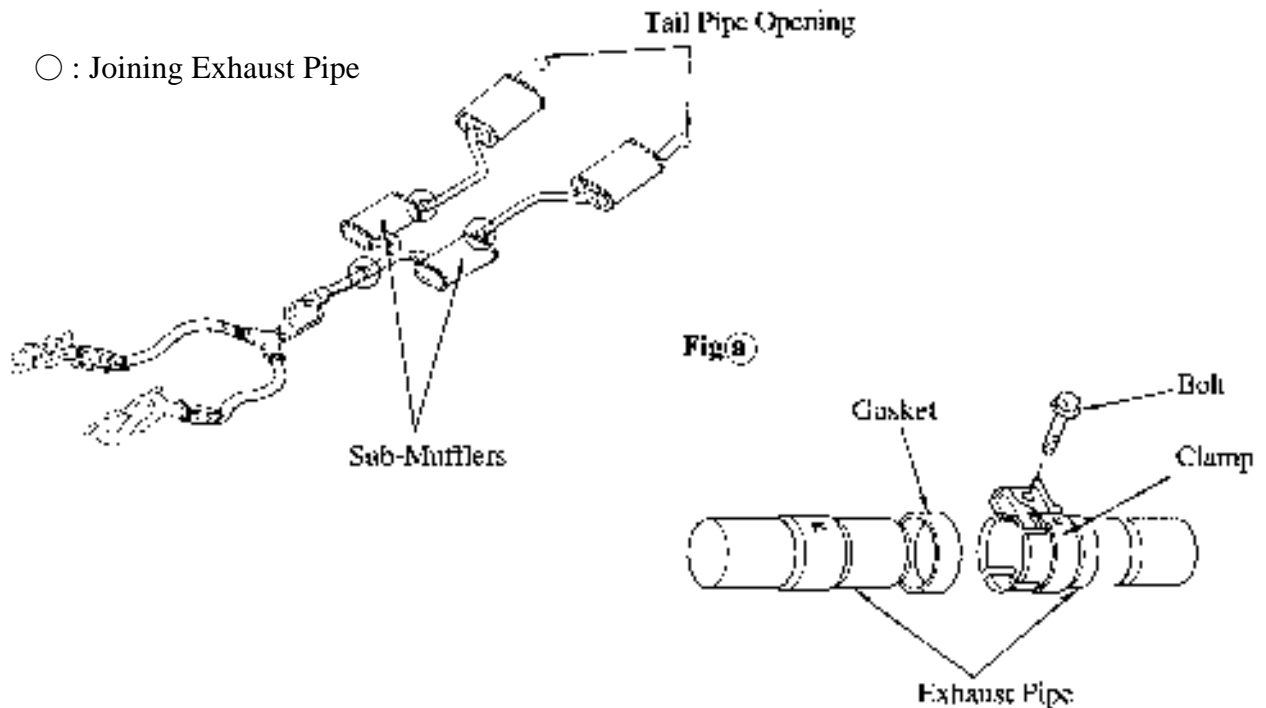

● ENGINE CONTROL SYSTEM

1. General

The engine control system of the new 1UZ-FE engine is basically the same in construction and operation as that of the previous 1UZ-FE engine. However, the new 1UZ-FE engine uses a sequential multiport fuel injection system, and a diagnosis system which conforms to OBD-II.

The engine control system of the new 1UZ-FE engine and previous 1UZ-FE engine are compared below.

System	Outline		New	Previous
SFI (Sequential Multiport Fuel Injection) [EFI]	An L-type SFI [EFI] system directly detects the intake air volume with a hot-wire type mass air flow meter.		○	—
	An L-type MFI*1 [EFI] system directly detects the intake air volume with an optical Karman-Vortex type volume air flow meter.		—	○
	The fuel injection system is a sequential multiport fuel injection system.		○	—
	The fuel injection system is a 4-group type and injects to 2 cylinders each.		—	○
	When starting the engine, the fuel injection system sprays fuel into all cylinders at the same time.		—	○
ESA (Electronic Spark Advance)	Ignition timing is determined by the ECM*2 [engine ECU] based on signals from various sensors. Corrects ignition timing in response to engine knocking.		○	○
	The torque control correction during gear shifting has been used to minimize the shift shock.		○	○
	The dwell angle control is implemented by the ECM*2 [engine ECU].		○	—
	2 knock sensors are used to further improve knock detection.		○	○
IAC (Idle Air Control) [ISC]	A step motor type IAC [ISC] system controls the fast idle and idle speeds.		○	○
Fuel Pump Control	Under light engine loads, pump speed is low to reduce electric power loss.	Uses a fuel pump relay and a fuel pump resistor.	○	—
		Uses fuel pump ECU.	—	○
Fuel Pressure Control	In hot engine condition, the fuel pressure is increased to improve restartability.		○	○
Oxygen Sensor Heater Control	Maintains the temperature of the oxygen sensor at an appropriate level to increase accuracy of detection of the oxygen concentration in the exhaust gas.		○	○

*1: MFI (Multiport Fuel Injection)

*2: ECM (Engine Control Module)

System	Outline	New	Previous
Air Conditioning Cut-Off Control	By controlling the air conditioning compressor ON or OFF in accordance with the engine condition, drivability is maintained.	○	○
EGR Control	Drives the EGR valve with step motor, controlling the EGR volume in accordance with the engine conditions.	○	○
Evaporative Emission Control	The ECM* ² [engine ECU] controls the purge flow of evaporative emissions (HC) in the charcoal canister in accordance with engine conditions.	○	○
Diagnosis	When the ECM* ² [engine ECU] detects a malfunction, the ECM* ² [engine ECU] diagnoses and memorizes the failed section.	○	○
	The diagnosis system complies with OBD-II. The diagnosis items (the failed sections) are discriminated by connecting the Lexus hand-held tester to the newly designed data link connector 3.	○	—
Fail-Safe	When the ECM* ² [engine ECU] detects a malfunction, the ECM* ² [engine ECU] stops or controls the engine according to the data already stored in memory.	○	○

*²: ECM (Engine Control Module)

2. Construction

The configuration of the engine control system in the 1UZ-FE engine of the new LS400 is as shown in the following chart. Shaded portions differ from the 1UZ-FE engine of the previous models.

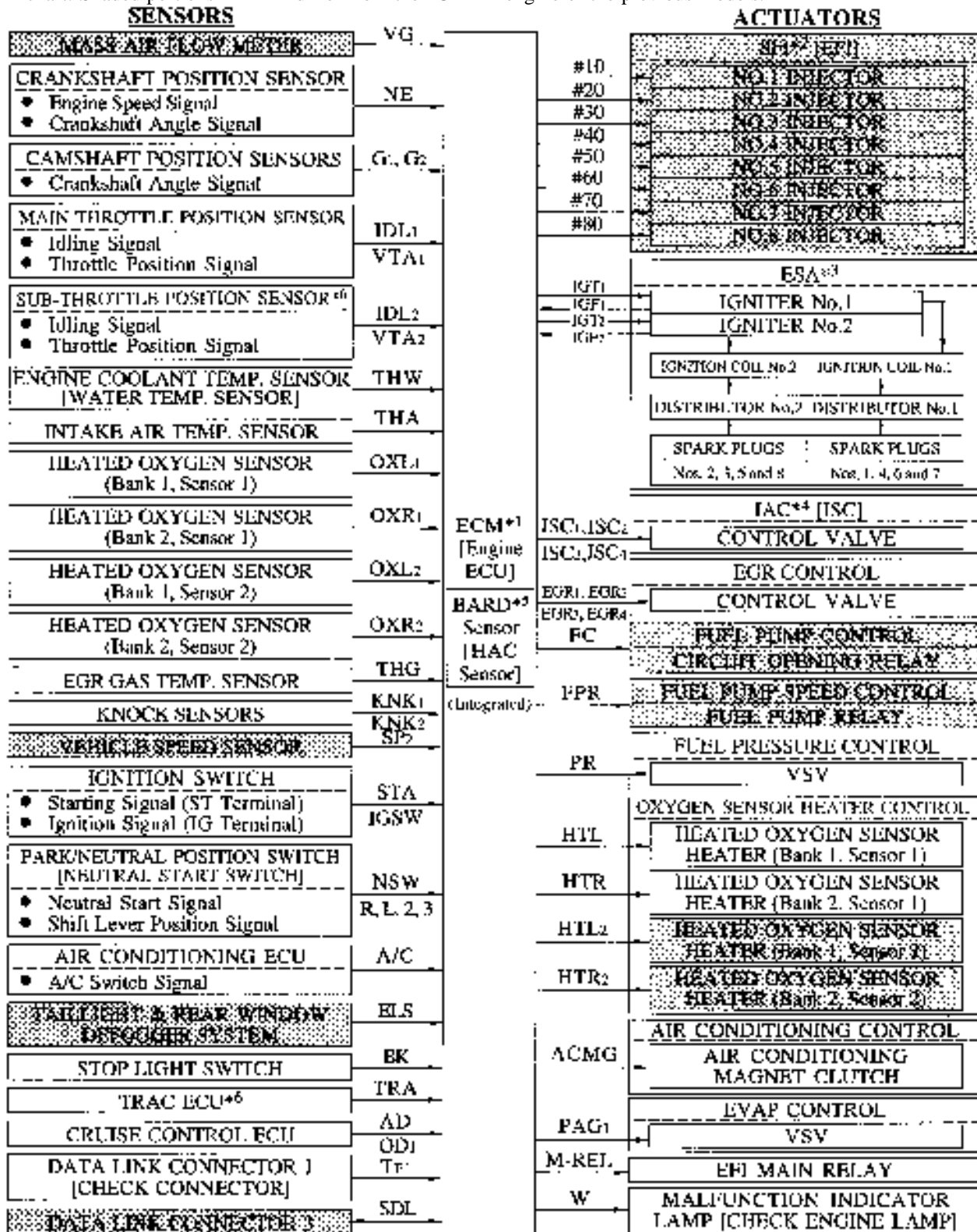

*1: ECM (Engine Control Module)
*2: SFI (Sequential Multipoint Fuel Injection)
*3: ESA (Electronic Spark Advance)

*4: IAC (Idle Air Control)
*5: BARD (Barometric Pressure)
*6: Vehicles equipped with the TRAC (Traction Control) System

3. Engine Control System Diagram

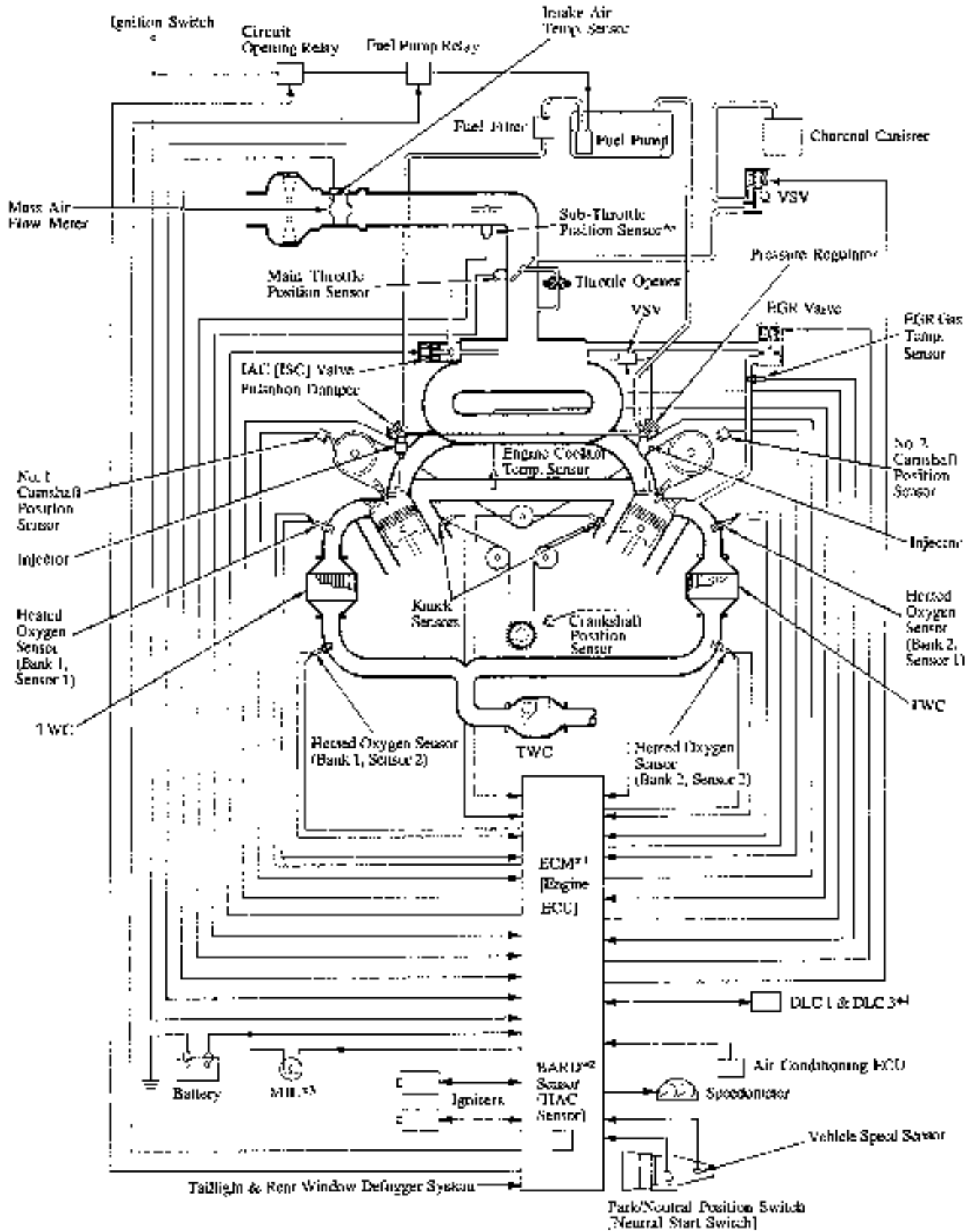

- *1: ECM (Engine Control Module)
- *2: BARD (Barometric Pressure)
- *3: MIL (Malfunction Indicator Lamp) [Check Engine Lamp]
- *4: DLC 1 & 3 (Data Link Connector 1) [Check Connector], (Data Link Connector 3)
- *5: Vehicles equipped with the TRAC (Traction Control) System

4. Layout of Components

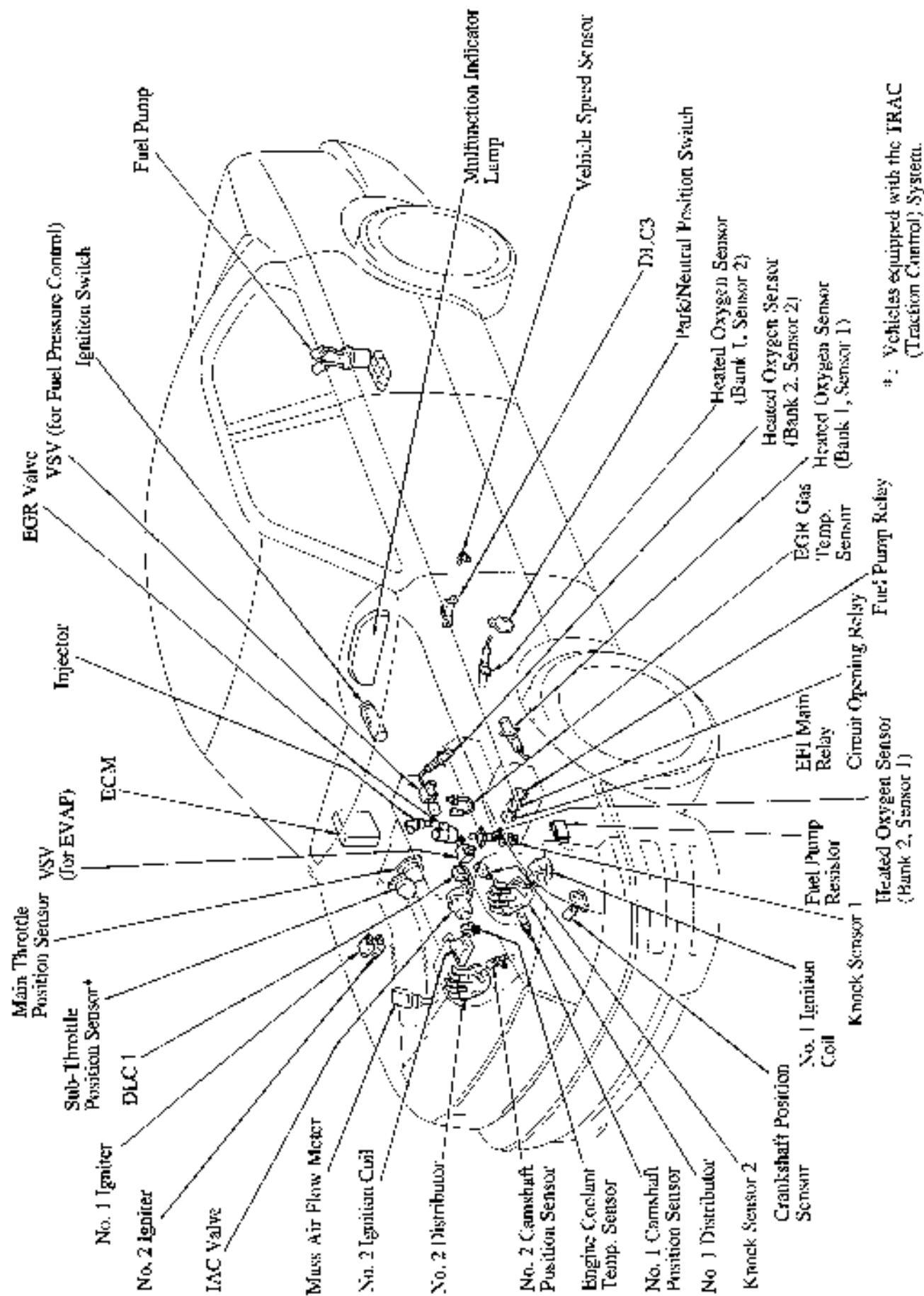

5. Main Components of Engine Control System

General

The following table compares the main components of the new 1UZ-FE engine and previous 1UZ-FE engine.

1UZ-FE Engine	New	Previous
Components		
Mass Air Flow Meter	Hot-Wire Type	—
Volume Air Flow Meter	—	Karman-Vortex Type
Crankshaft Position Sensor	Pick-Up Coil Type, 1	←
Camshaft Position Sensor	Pick-Up Coil Type, 2	←
Throttle Position Sensor	Linear Type	←
Knock Sensor	Built-In Piezoelectric Type, 2	←
Oxygen Sensor	Heated Oxygen Sensor (Bank 1, Sensor 1) (Bank 2, Sensor 1) (Bank 1, Sensor 2) (Bank 2, Sensor 2)	Main Heated Oxygen Sensors (LH Bank and RH Bank) Sub-Oxygen Sensors (LH Bank and RH Bank)
Injector	2-Hole Type	←
IAC [ISC] Valve	Step Motor Type	←

Mass Air Flow Meter

The hot-wire type mass air flow meter is designed for direct electrical measurement of the intake air mass flow. It has the following features:

- Compact and lightweight
- Ability to measure a wide intake air mass flow
- Superior response and measuring accuracy
- Having no mechanical functions, it offers superior durability.

For details of the principle and operation of the hot-wire type mass air flow meter, see the '94 model Lexus New Car Features (Pub. No. NCF098U), page 33.

6. SFI (Sequential Multiport Fuel Injection) [EFI]

In place of the L-type MFI (Multiport Fuel Injection) [EFI] system with an optical Karman-Vortex type volume air flow meter used in the previous 1UZ-FE engine, the new 1UZ-FE engine uses the L-type SFI [EFI] system with a hot-wire type mass air flow meter. Compared to the previous 1UZ-FE engine, the new 1UZ-FE engine with SFI [EFI] offers the following characteristics:

- Adopts a hot-wire type mass air flow meter with superior measuring precision.
- In place of the 4-group type fuel injection pattern used by the previous 1UZ-FE engine, the new 1UZ-FE adopts a sequential multiport fuel injection type pattern.

Fuel Injection Pattern and Fuel Injection Timing

The new 1UZ-FE engine adopts a sequential multiport fuel injection system in which the air-fuel mixture is introduced into each cylinder every time the engine completes two revolutions. It also optimally regulates the injection timing according to the engine condition.

7. ESA (Electronic Spark Advance)

The ESA system of the new 1UZ-FE engine is basically the same in construction and operation as that of the previous 1UZ-FE engine. However, the dwell angle control which was executed by the igniter is now implemented by the ECM* [engine ECU] in the new model.

8. IAC (Idle Air Control) [ISC]

The IAC system of the new 1UZ-FE engine is basically the same in construction and operation as that of the previous 1UZ-FE engine. However, the new 1UZ-FE engine uses an electrical load estimate correction function. The target idle speed thus varies according to electrical loads such as taillights or rear window defogger.

9. Fuel Pump Control

As in the 1UZ-FE engine of the previous models, this system switches the fuel pump speed between high and low speed according to engine conditions, reducing the electrical load. However, in the new 1UZ-FE engine, the fuel pump speed switching components has been changed from the fuel pump control ECU to fuel pump control relay and resistor. This system is basically the same as that used in the 1UZ-FE engine of the '91 LS400. For details, see '90 LS400 New Car Features (Pub. No. NCF054U) on page 148.

10. Diagnosis

The diagnosis system of the new 1UZ-FE engine complies with OBD-II. For OBD-II requirements, see '94 model Lexus New Car Features (Pub. No. NCF098U), page 2. For details of the following items, refer to the '95 LS400 Repair Manual (Pub. No. RM405U1).

Item	Contents
Data Link Connector	Data Link Connector 3 added for OBD-II.
Diagnostic Trouble Code Check Method	Perform by connecting the Lexus hand-held tester to Data Link Connector 3.
Diagnostic Trouble Code	—
ECM* [Engine ECU] Memory Items	Freezed frame data added.

*: ECM (Engine Control Module)

11. Fail-Safe

The fail-safe functions of the new 1UZ-FE engine are as follows:

Circuit with Abnormal Signals	Fail-Safe Function
Mass Air Flow Meter Signal (VG)	Fixed values (standard values) based on the condition of the STA signal and IDL contacts are used for the fuel injection duration and the ignition timing (5° BTDC), making engine operation possible.
Engine Coolant Temp. Sensor [Water Temp. Sensor] Signal (THW)	Fixed value (standard value) is used: 80°C (176°F) for engine coolant temp.
Intake Air Temp. Sensor Signal (THA)	Fixed value (standard value) is used: 20°C (68°F) for intake air temp.
Barometric Pressure Sensor [High Altitude Compensation Sensor] Signal (HAC)	Fixed value of 760 mmHg is used.
Main and Sub Throttle Position Sensor Signal (VTA1, 2)	A fixed value of 0° throttle valve opening angle is used.
<ul style="list-style-type: none"> • Knock Sensor Signal (KNK1, 2) • Knock Control System 	The corrective retard angle value is set to the maximum value.
Ignition Confirmation Signal (IGF1, 2)	Fuel injection is stopped.

● EMISSION CONTROL SYSTEM

1. EGR (Exhaust Gas Recirculation) System

In addition to the EGR system components used in the previous model, an EGR gas cooler is adopted. It is enclosed in the rear water bypass joint in the back of the engine and uses the engine coolant to cool the exhaust gases which are later drawn into the intake air chamber. This system suppresses the intake air temperature from rising due to the exhaust gases and thus improves the engine's anti-knocking performance.

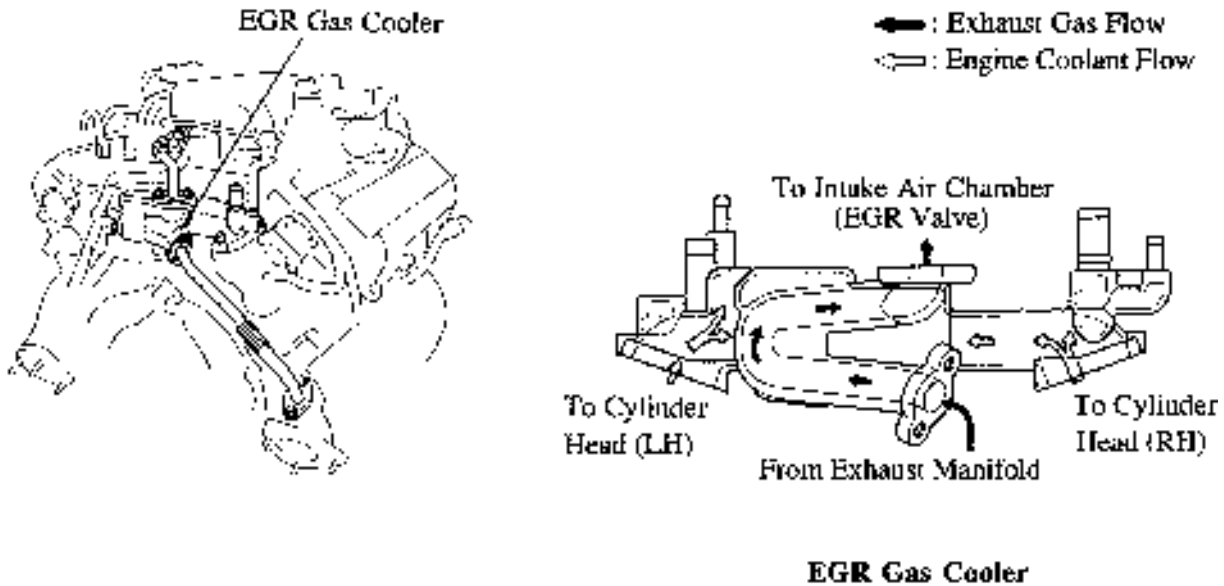

2. Evaporative Emission Control System

Charcoal Canister

The construction of the charcoal canister for the California specification models is changed and its capacity is increased (1.4 L → 2.0 L) to improve the canister's HC absorption performance and efficiency. The construction of the charcoal canister is basically the same as the '95 ES300; see the '95 model Lexus New Car Features (Pub. No. NCF110U), page 8.

MAJOR TECHNICAL SPECIFICATIONS

Item	Area	U.S.A.	Canada		
Body Type		4 Door Sedan			
Vehicle Grade		—			
Model Code		UCF20L-AEPGKA	UCF20L-AEPGKK		
Major Dimensions & Vehicle Weights	Overall	Length mm (in.)	4995 (196.7)	←	
		Width mm (in.)	1830 (72.0)	←	
		Height mm (in.)	1420 (55.9)	←	
	Wheel Base	mm (in.)	2850 (112.2)	←	
	Tread	Front mm (in.)	1575 (62.0)	←	
		Rear mm (in.)	1575 (62.0)	←	
	Effective Head Room	Front mm (in.)	989 (38.9), 965 (37.9)*1	←	
		Rear mm (in.)	938 (36.9), 907 (35.7)*1	←	
	Effective Leg Room	Front mm (in.)	1109 (43.7)	←	
		Rear mm (in.)	938 (36.9)	←	
	Shoulder Room	Front mm (in.)	1470 (57.9)	←	
		Rear mm (in.)	1450 (57.1)	←	
	Overhang	Front mm (in.)	900 (35.4)	←	
		Rear mm (in.)	1245 (49.0)	←	
	Min. Running Ground Clearance	mm (in.)	140 (5.5), 135 (5.3)*2	140 (5.5)	
	Angle of Approach	degrees	15	←	
	Angle of Departure	degrees	16, 15*2	16	
	Curb Weight	Front kg (lb)	910 (2005)	920 (2028)	
		Rear kg (lb)	745 (1645)	755 (1664)	
		Total kg (lb)	1655 (3650)	1675 (3692)	
Gross Vehicle Weight	Front kg (lb)	1050 (2315)	1030 (2271)		
	Rear kg (lb)	1105 (2435)	1105 (2436)		
	Total kg (lb)	2155 (4750)	2135 (4707)		
Fuel Tank Capacity	L (U.S. gal., Imp. gal.)	85 (22.5, 18.7)	←		
Luggage Compartment Capacity	m ³ (cu. ft.)	0.41 (14.6)	←		
Performance	Max. Speed	km/h (mph)	240 (149)	←	
	Max. Cruising Speed	km/h (mph)	215 (134)	←	
	Acceleration	0 to 100 km/h	sec.	—	←
		0 to 400 m	sec.	15.2	←
	Max. Permissible Speed	1st Gear	km/h (mph)	73 (45)	←
		2nd Gear	km/h (mph)	134 (83)	←
		3rd Gear	km/h (mph)	—	←
		4th Gear	km/h (mph)	—	←
Turning Diameter (Outside Front)	Wall to Wall	m (ft.)	11.4 (37.4)	←	
	Curb to Curb	m (ft.)	10.6 (34.8)	←	
Engine	Engine Type	1UZ-FE			
	Valve Mechanism	32 Valve, DOHC			
	Bore x Stroke	mm (in.)	87.5 x 82.5 (3.44 x 3.25)	←	
	Displacement	cm ³ (cu. in.)	3969 (242.1)	←	
	Compression Ratio	10.4 : 1			
	Carburetor Type	SFI			
	Research Octane No.	RON	96	←	
	Max. Output (SAE-NET)	kW/rpm (HP @ rpm)	194/5300 (260@5300)	←	
	Max. Torque (SAE-NET)	N·m/rpm (lb-ft @ rpm)	366/4500 (270@4500)	←	
	Engine Electrical	Battery Capacity (5HR)	Voltage & Amp. hr.	12-55	←
Generator [Alternator] Output		Watts	960	←	
Starter Output		kW	2.0	←	
Chassis	Clutch Type	—			
	Transmission Type	A340E			
	Transmission Gear Ratio	In First	2.804	←	
		In Second	1.531	←	
		In Third	1.000	←	
		In Fourth	0.705	←	
		In Fifth	—	←	
		In Reverse	2.393	←	
	Differential Gear Ratio	3.615			
	Differential Gear Size	in.	8"	←	
	Brake Type	Front	Ventilated Disc		
		Rear	Ventilated Disc		
	Parking Brake Type	Duo Servo		←	
	Brake Booster Type and Size	in.	Tandem, 8" + 9"		
	Proportioning Valve Type	—		←	
	Suspension Type	Front	Double Wishbone		
		Rear	Double Wishbone		
Stabilizer Bar	Front	STD			
	Rear	STD			
Steering Gear Type	Rack & Pinion		←		
Steering Gear Ratio (Overall)	18.7 : 1		←		
Power Steering Type	Integral Type		←		

*1 : with Air Suspension
 *2 : with Moon Roof

LS400

OUTLINE OF NEW FEATURES

Since its introduction, the LS400 has won a reputation as a high-performance and high-quality luxury sedan.

The following improvements have been made for the 1996 model year.

1. 1UZ-FE Engine (See GENERAL 1996 FEATURES for Details)

A diagnosis function for the evaporative emission control system has been added to the diagnosis system.

2. Cruise Control System

For the '95 model, the shift position in which driver can set the cruise control speed has been changed from only "D" range to "D" range or "3rd" range.

1UZ-FE Engine

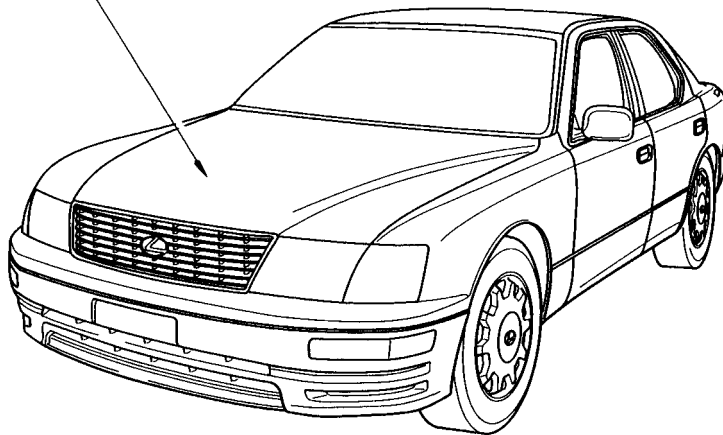

NEW FEATURES

● INTERIOR EQUIPMENT

1. Power Outlet

A power outlet is provided in the lower center console box to enable accessories such as portable telephone to be connected. As a result, the power cord of a portable telephone can be stored inside the console box, thus improving the appearance around the console box.

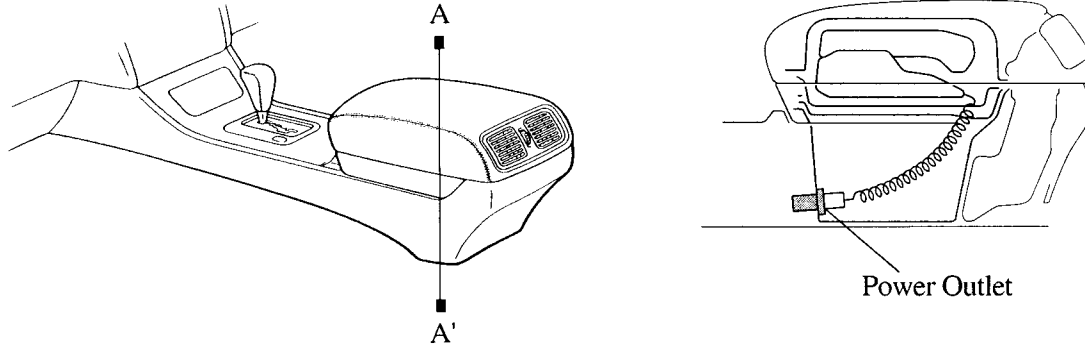

A-A' Cross Section

● 1UZ-FE ENGINE

1. Engine Control System

The following changes have been made to the engine control system.

IAC (Idle Air Control)

With the shift lever in the “D” range and the air conditioner ON, the idle speed has been changed from 700 rpm to 650 rpm.

Engine Immobiliser System

The engine immobiliser system has been designed to prevent the vehicle from being stolen. The system uses a transponder key computer that stores the ID code of the authorized ignition key. If an attempt is made to start the engine using an unauthorized key, the transponder key computer emits a signal to the ECM to prohibit fuel delivery and ignition to disable the engine effectively. For details, see page 40 in the Engine Immobiliser System section.

3. Major Differences

The following changes have been made to the 1UZ-FE engine.

System	Features
Engine Proper	<ul style="list-style-type: none"> ● An upright intake port has been adopted to improve the intake efficiency. ● A taper squish configuration has been adopted to improve the combustion efficiency. ● A steel laminate type cylinder head gasket has been adopted to improve its reliability. ● The cylinder block and the crankshaft have been made more rigid to realize a quieter operation. ● The skirt portion of the piston has been changed in shape and applied with resin coating to reduce friction.
Valve Mechanism	<ul style="list-style-type: none"> ● The VVT-i system is used to improve fuel economy, engine performance and reduce exhaust emissions. ● The valve adjusting shim has been changed from the outer shim type to the inner shim type. ● The valve diameter of the intake and exhaust valves has been increased to reduce intake and exhaust resistance.
Lubrication System	Reinforcement ribs have been added to the No. 1 oil pan to improve the rigidity of the coupling of the engine with the transmission, and to reduce noise.
Cooling System	The opening valve diameter of the thermostat has been increased to improve the cooling performance.
Intake and Exhaust System	<ul style="list-style-type: none"> ● A long port intake manifold is used to improve the engine's torque in the low-to mid speed range. ● ACIS (Acoustic Control Induction System) is used to deliver high power output in all engine speed ranges. ● A long tail muffler is used to ensure quieter operation during idling.
Fuel System	<ul style="list-style-type: none"> ● A fuel returnless system has been adopted to reduce evaporative emissions. ● An air assist fuel injection system is used to promote atomizing of the fuel for improved fuel economy. ● 4-hole type fuel injectors have been adopted to improve the atomization of fuel.
Ignition System	<ul style="list-style-type: none"> ● The DIS (Direct Ignition System) is used to enhance the reliability of the ignition system. ● Iridium-tipped spark plugs have been adopted to improve ignition.
Engine Control System	<ul style="list-style-type: none"> ● ETCS-i has been adopted to realize excellent controllability and comfort of the vehicle. ● The cruise control system and the engine immobiliser system have been integrated with the ECM.

● 1UZ-FE ENGINE

1. Description

The 1UZ-FE engine has adopted the VVT-i (Variable Valve Timing-intelligent) system and the ACIS (Acoustic Control Induction System) to improve engine performance and fuel economy and to reduce exhaust emissions.

In addition, it has adopted the ETCS-i (Electronic Throttle Control System-intelligent) to ensure excellent controllability of the vehicle and to improve its comfort.

2. Engine Specifications and Performance Curve

1UZ-FE Engine			'98 LS400	'97 LS400
Item				
No. of Cyls. & Arrangement			8-Cylinder, V Type	←
Valve Mechanism			32-Valve DOHC, Belt & Gear Drive	←
Combustion Chamber			Pentroof Type	←
Manifolds			Cross-Flow	←
Fuel System			SFI	←
Displacement	cm ³ (cu. in.)		3969 (242.1)	←
Bore × Stroke	mm (in.)		87.5 × 82.5 (3.44 × 3.25)	←
Compression Ratio			10.5 : 1	10.4 : 1
Max. Output	[SAE-NET]		216 kW @ 6000 rpm (290HP @ 6000rpm)	194 kW @ 5300 rpm (260HP @ 5300 rpm)
Max. Torque	[SAE-NET]		407 N·m @ 4000 rpm (300 ft·lb @ 4000 rpm)	366 N·m @ 4500 rpm (270 ft·lb @ 4500 rpm)
Valve Timing	Intake	Open	-14° 36° BTDC	6° BTDC
		Close	64° 14° ABDC	46° BTDC
	Exhaust	Open	46° BBDC	←
		Close	3° ATDC	←
Fuel Octane Number	(RON)		96	←
Oil Grade			API SH EC-II, SJ EC or ILSAC	API SH EC-II or ILSAC

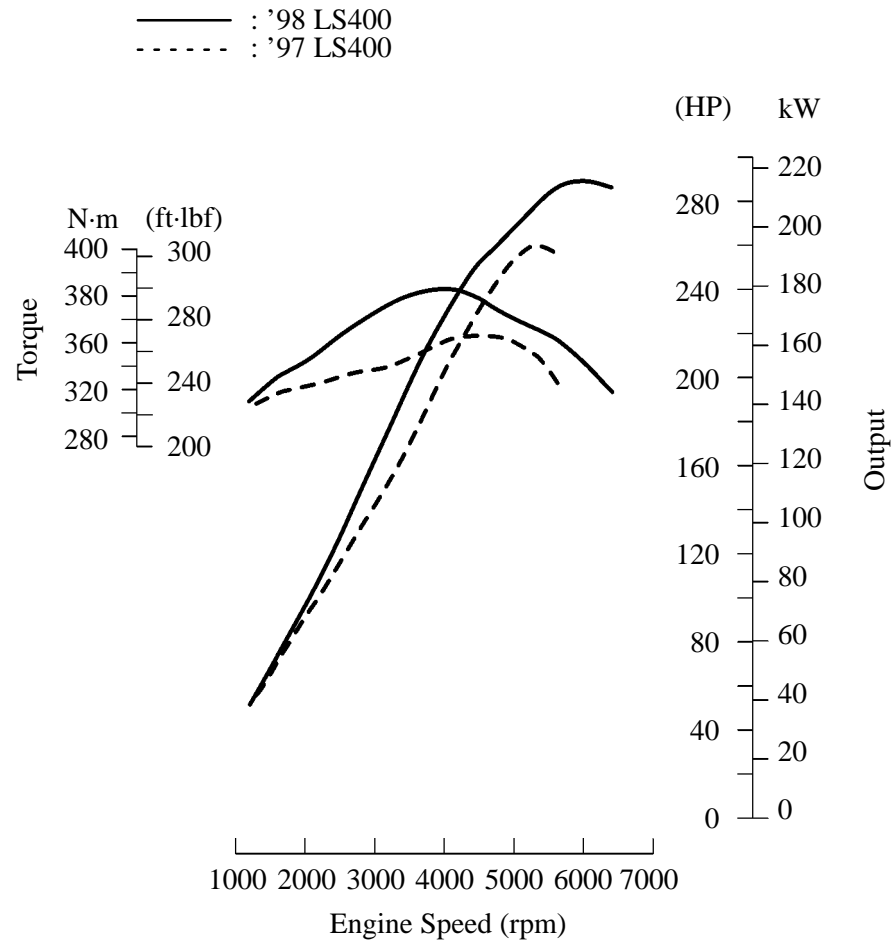

3. Major Differences

The following changes have been made to the 1UZ-FE engine.

System	Features
Engine Proper	<ul style="list-style-type: none"> ● An upright intake port has been adopted to improve the intake efficiency. ● A taper squish configuration has been adopted to improve the combustion efficiency. ● A steel laminate type cylinder head gasket has been adopted to improve its reliability. ● The cylinder block and the crankshaft have been made more rigid to realize a quieter operation. ● The skirt portion of the piston has been changed in shape and applied with resin coating to reduce friction.
Valve Mechanism	<ul style="list-style-type: none"> ● The VVT-i system is used to improve fuel economy, engine performance and reduce exhaust emissions. ● The valve adjusting shim has been changed from the outer shim type to the inner shim type. ● The valve diameter of the intake and exhaust valves has been increased to reduce intake and exhaust resistance.
Lubrication System	Reinforcement ribs have been added to the No. 1 oil pan to improve the rigidity of the coupling of the engine with the transmission, and to reduce noise.
Cooling System	The opening valve diameter of the thermostat has been increased to improve the cooling performance.
Intake and Exhaust System	<ul style="list-style-type: none"> ● A long port intake manifold is used to improve the engine's torque in the low-to mid speed range. ● ACIS (Acoustic Control Induction System) is used to deliver high power output in all engine speed ranges. ● A long tail muffler is used to ensure quieter operation during idling.
Fuel System	<ul style="list-style-type: none"> ● A fuel returnless system has been adopted to reduce evaporative emissions. ● An air assist fuel injection system is used to promote atomizing of the fuel for improved fuel economy. ● 4-hole type fuel injectors have been adopted to improve the atomization of fuel.
Ignition System	<ul style="list-style-type: none"> ● The DIS (Direct Ignition System) is used to enhance the reliability of the ignition system. ● Iridium-tipped spark plugs have been adopted to improve ignition.
Engine Control System	<ul style="list-style-type: none"> ● ETCS-i has been adopted to realize excellent controllability and comfort of the vehicle. ● The cruise control system and the engine immobiliser system have been integrated with the ECM.

4. Engine Proper

Cylinder Head Cover Gasket

The cross sectional shape of the cylinder head cover gasket has been changed to improve its reliability.

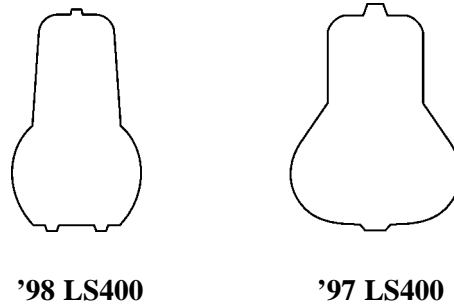

151EG33

Cylinder Head

- The intake port has been changed to the upright type to improve intake efficiency.
- A taper squish combustion chamber has been adopted to improve anti-knocking performance and intake efficiency. In addition, engine performance and fuel economy have been improved.
- **Cylinder Head** ◀

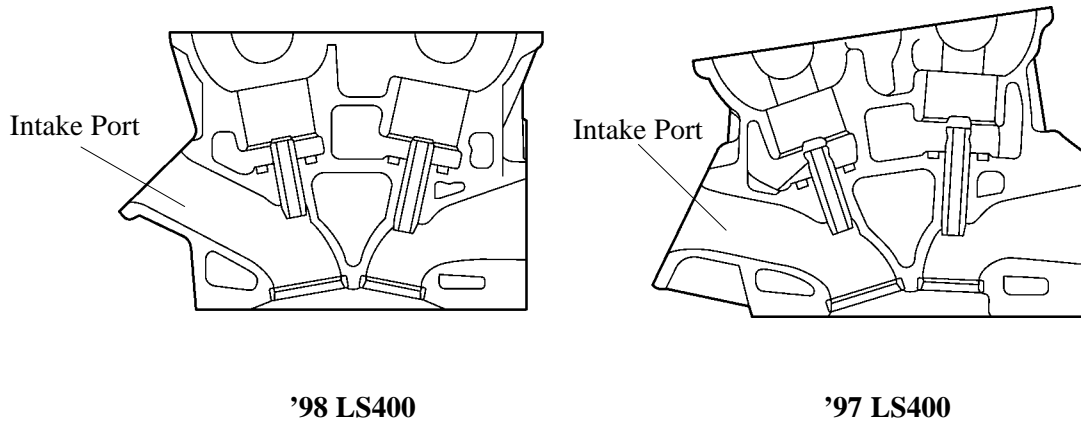

151EG03

- **Taper Squish Combustion Chamber** ◀

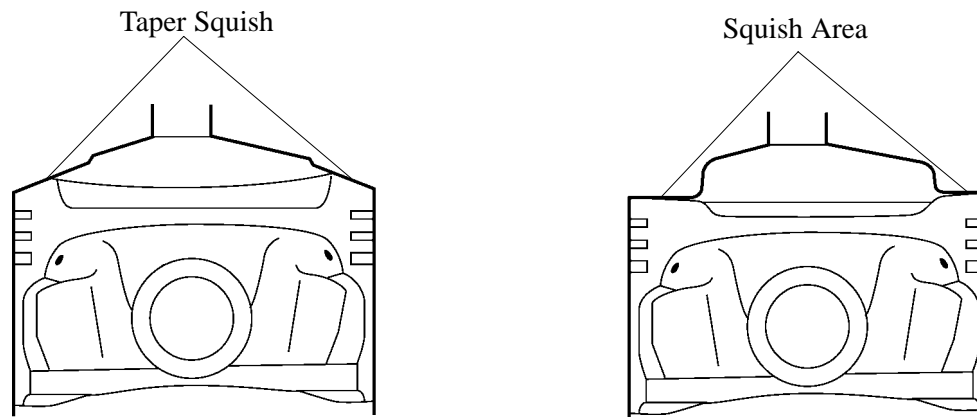

Taper Squish Combustion Chamber

Conventional Combustion Chamber

151EG04

Cylinder Head Gasket

The cylinder head gasket has been changed from the previous carbon graphite type to the steel laminate type to improve reliability and to minimize the deformation of the cylinder bore. This reduced the consumption rate of engine oil, improved fuel economy, and reduced exhaust emissions.

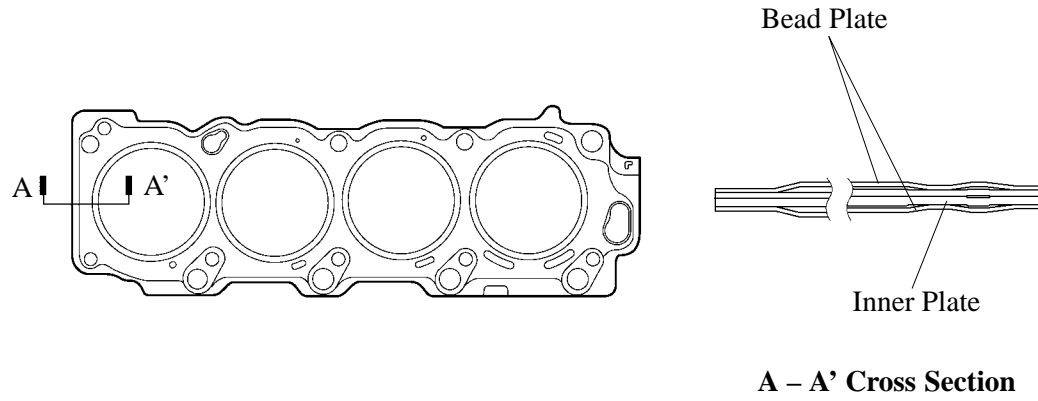

151EG71

Piston

- Along with the improved engine performance, the piston skirt has been changed in shape and applied with resin coating to reduce friction loss.
- The piston head portion has adopted a taper squish shape to improve the fuel combustion efficiency.

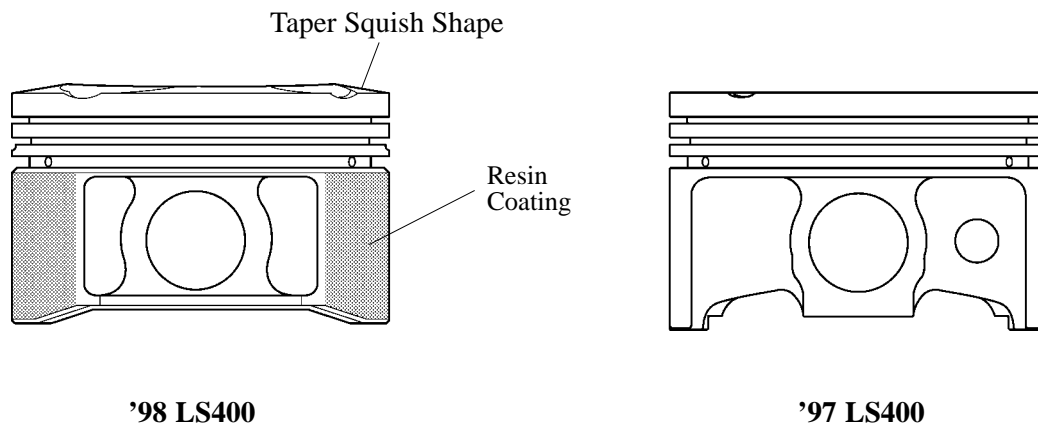

151EG41

5. Valve Mechanism

Camshaft

- In conjunction with the adoption of the VVT-i system, the scissors gear has been relocated from the center of the camshaft to the front of the camshaft.
- In conjunction with the adoption of the VVT-i system, an oil passage is provided in the intake camshaft in order to supply engine oil to the VVT-i system.
- The intake camshaft is provided with timing rotor to trigger the VVT sensor.

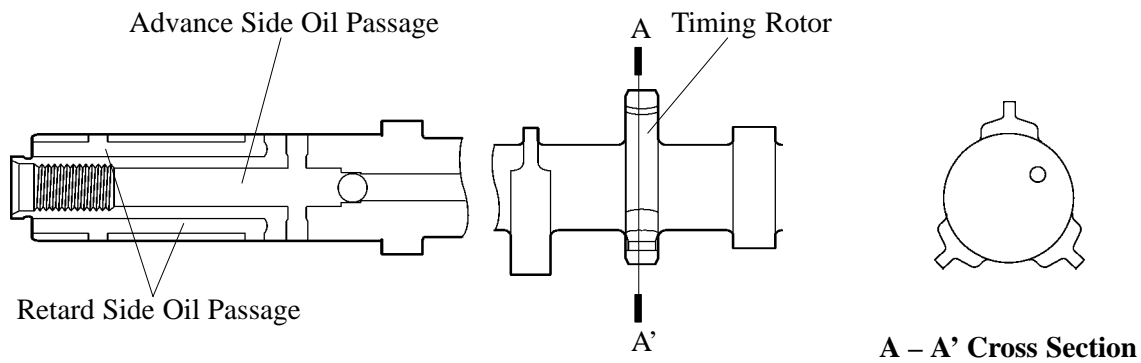

151EG24

151EG25

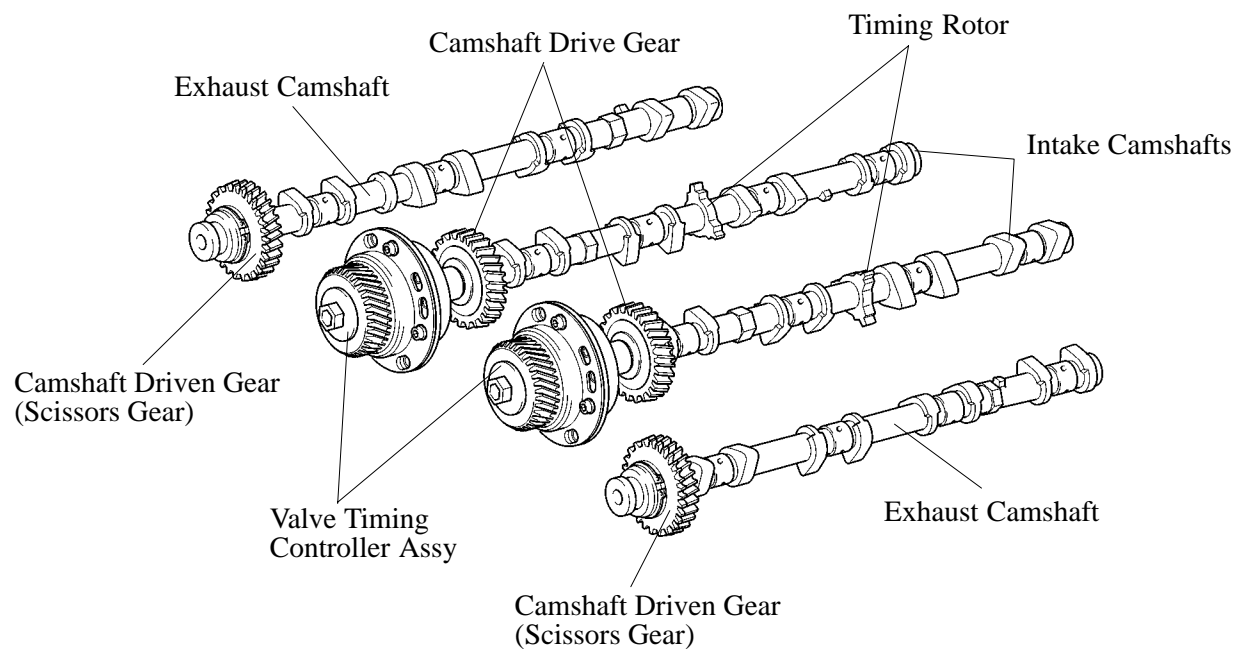

151EG26

Intake and Exhaust Valve and Valve Lifter

- The valve face diameter of the intake and exhaust valves has been increased to improve the intake and exhaust efficiency. In addition, the stem diameter has been reduced to reduce the intake and exhaust resistance and for weight reduction.
- In conjunction with the increase in the amount of valve lift, the valve lifter has been changed to the inner shim type. Accordingly, the valve lifter has been changed from aluminum to steel.
- The valve lifter, which has been made lighter and thinner, provides crowning on its side sliding portion to reduce noise and friction.
- The cross sectional shape of the valve spring has been changed from egg-shape to a round shape with a smaller diameter for weight reduction.

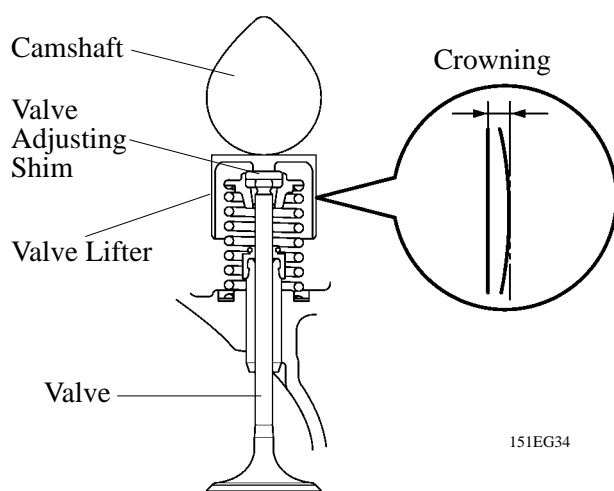

● Specifications ◀

mm (in.)

Valve	Intake		Exhaust	
	New	Pre-vious	New	Pre-vious
Face Diameter	34.5 (1.36)	33.5 (1.32)	29.0 (1.14)	28.0 (1.10)
Stem Diameter	5.5 (0.22)	6.0 (0.24)	5.5 (0.22)	6.0 (0.24)

151EG34

Timing Belt Cover

- The timing belt cover No. 3 is made of aluminum to reduce noise.
- The timing belt cover No. 1 and No. 2 are composite formed with a gasket to improve serviceability.

Timing Belt Cover No. 3

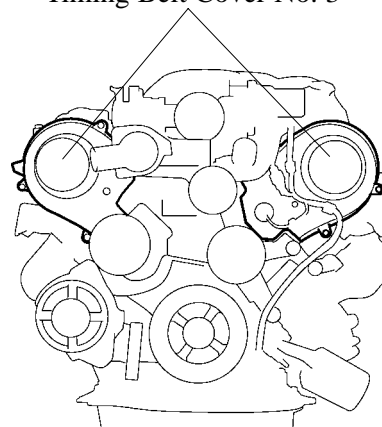

151EG12

6. Intake and Exhaust System

Throttle Body

- The adoption of the ETCS-i has realized excellent throttle control.
- The ISC system, VSC system, and cruise control system are controlled comprehensively by the ETCS-i. Thus, the IAC valve and the sub-throttle valve have been discontinued.
- A thermostat is installed in the throttle body. The thermostat uses the thermal expansion of the wax to open and close the valve to shut off the flow of warm coolant when the coolant temperature is high in the throttle body's warm coolant passage. This prevents the throttle body temperature from rising more than the needed level, thus restraining the rise in the intake air temperature.

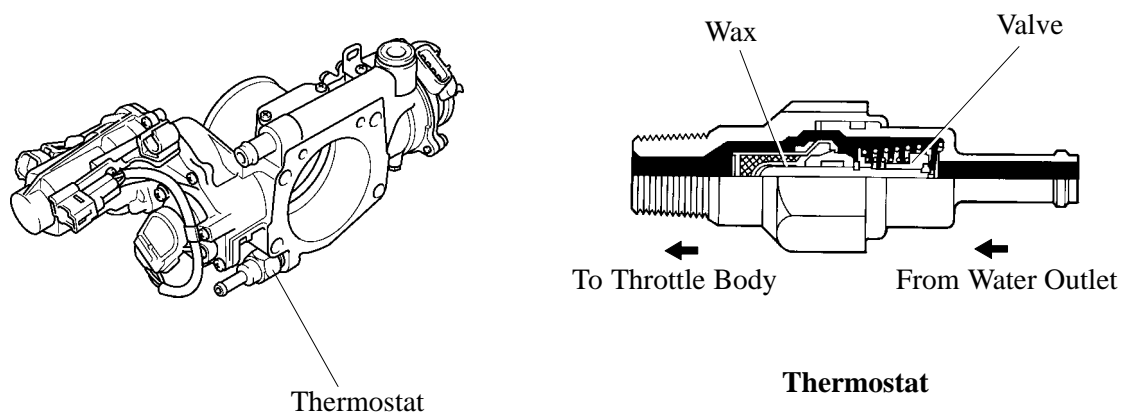

151EG21

150EG21

Intake Manifold

- The low-to mid-speed range torque has been improved by increasing the length of the intake manifold port.
- The intake air chamber consists of upper and lower sections and contains an intake air control valve. This valve is activated by ACIS (Acoustic Control Induction System) and is used to alter the intake pipe length to improve the engine performance in all speed ranges.

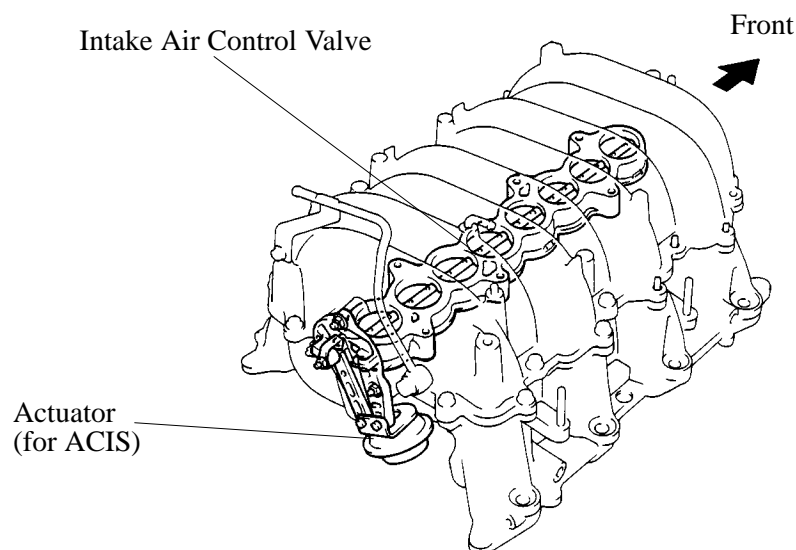

151EG11

Intake Manifold Gasket

- A heat-barrier gasket has been adopted for use between the cylinder head and the intake manifold. This gasket, which restrains the heat transfer from the cylinder head to the intake manifold, helps restrain the intake air temperature and improve the charging efficiency.
- The construction of the gasket consists of resin that is sandwiched between metal gaskets.

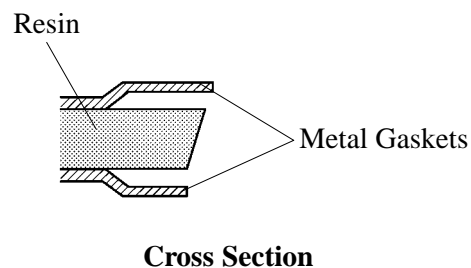
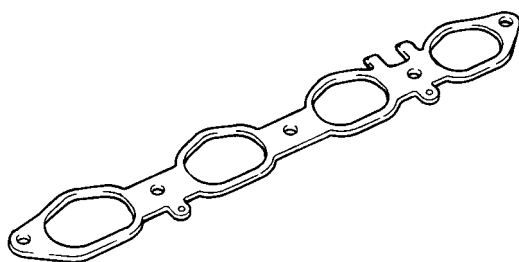

151EG69

144EG04

Long Tail Muffler

The internal construction of the main muffler has been changed and the tail pipe length has been extended to realize a quieter operation during idle.

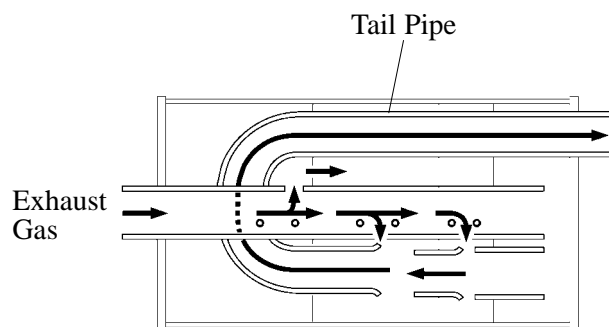

'98 LS400

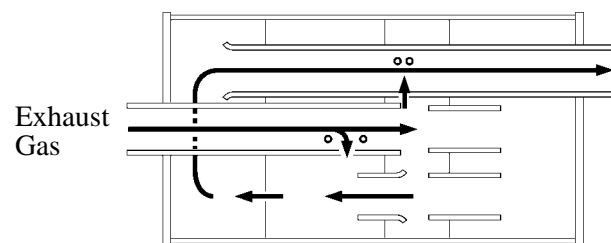

'97 LS400

151EG10

9. Engine Control System

General

The engine control system has been changed from that of the '97 LS400 in the areas described below.

- The VVT-i, ETCS-i, and ACIS systems have been adopted.
- The cruise control system and the engine immobiliser system have been integrated with the ECM.
- A function to communicate with the multiplex communication system has been added.

The engine control system of the 1UZ-FE engine in the '98 LS400 and '97 LS400 are compared below.

System	Outline	'98 LS400	'97 LS400
SFI (Sequential Multiport Fuel Injection)	A L-type SFI system directly detects the intake air volume with a hot-wire type mass air flow meter.	○	○
	The fuel injection system is a sequential multiport fuel injection system.	○	○
ESA (Electronic Spark Advance)	Ignition timing is determined by the ECM based on signals from various sensors. Corrects ignition timing in response to engine knocking.	○	○
	The torque control correction during gear shifting has been used to minimize the shift shock.	○	○
	2 knock sensors are used to further improve knock detection.	○	○
IAC (Idle Air Control)	A step motor type IAC system controls the fast idle and idle speeds.	—	○
VVT-i (Variable Valve Timing-intelligent)	Controls the intake camshaft to an optimal valve timing in accordance with the engine condition.	○	—
ETCS-i (Electronic Throttle Control System-intelligent)	Optimally controls the throttle valve opening in accordance with the amount of the accelerator pedal effort, and the conditions of the engine and the vehicle, and comprehensively controls the ISC, cruise control, and the VSC system.	○	—
ACIS (Acoustic Control Induction System)	The intake air passages are switched according to the engine speed and throttle valve opening angle to provide high performance in all speed ranges.	○	—
Fuel Pump Control	Under light engine loads, pump speed is low to reduce electric power loss.	○	○
Fuel Pressure Control	In hot engine condition, the fuel pressure is increased to improve restartability.	—	○
Oxygen Sensor Heater Control	Maintains the temperature of the oxygen sensor at an appropriate level to increase accuracy of detection of the oxygen concentration in the exhaust gas.	○	○
Air Conditioning Cut-Off Control	By controlling the air conditioning compressor ON or OFF in accordance with the engine condition, drivability is maintained.	○	○
EGR Control	Drives the EGR valve with step motor, controlling the EGR volume in accordance with the engine conditions.	—	○

(Continued)

System	Outline	'98 LS400	'97 LS400
Evaporative Emission Control	The ECM controls the purge flow of evaporative emissions (HC) in the charcoal canister in accordance with engine conditions.	○	○
Engine Immobiliser	Prohibits fuel delivery and ignition if an attempt is made to start the engine with an invalid ignition key.	○	○
Function to communicate with multiplex communication system	Communicates with the body ECU, A/C ECU, etc., on the body side, to input/output necessary signals.	○	—
Diagnosis	When the ECM detects a malfunction, the ECM diagnoses and memorizes the failed section.	○	○
	The diagnosis system includes a function that detects a malfunction in the evaporative emission control system.	○	○
Fail-Safe	When the ECM detects a malfunction, the ECM stops or controls the engine according to the data already stored in the memory.	○	○

Construction

The configuration of the engine control system in the 1UZ-FE engine of the '98 LS400 is as shown in the following chart. Shaded portions differ from the 1UZ-FE engine of the '97 LS400.

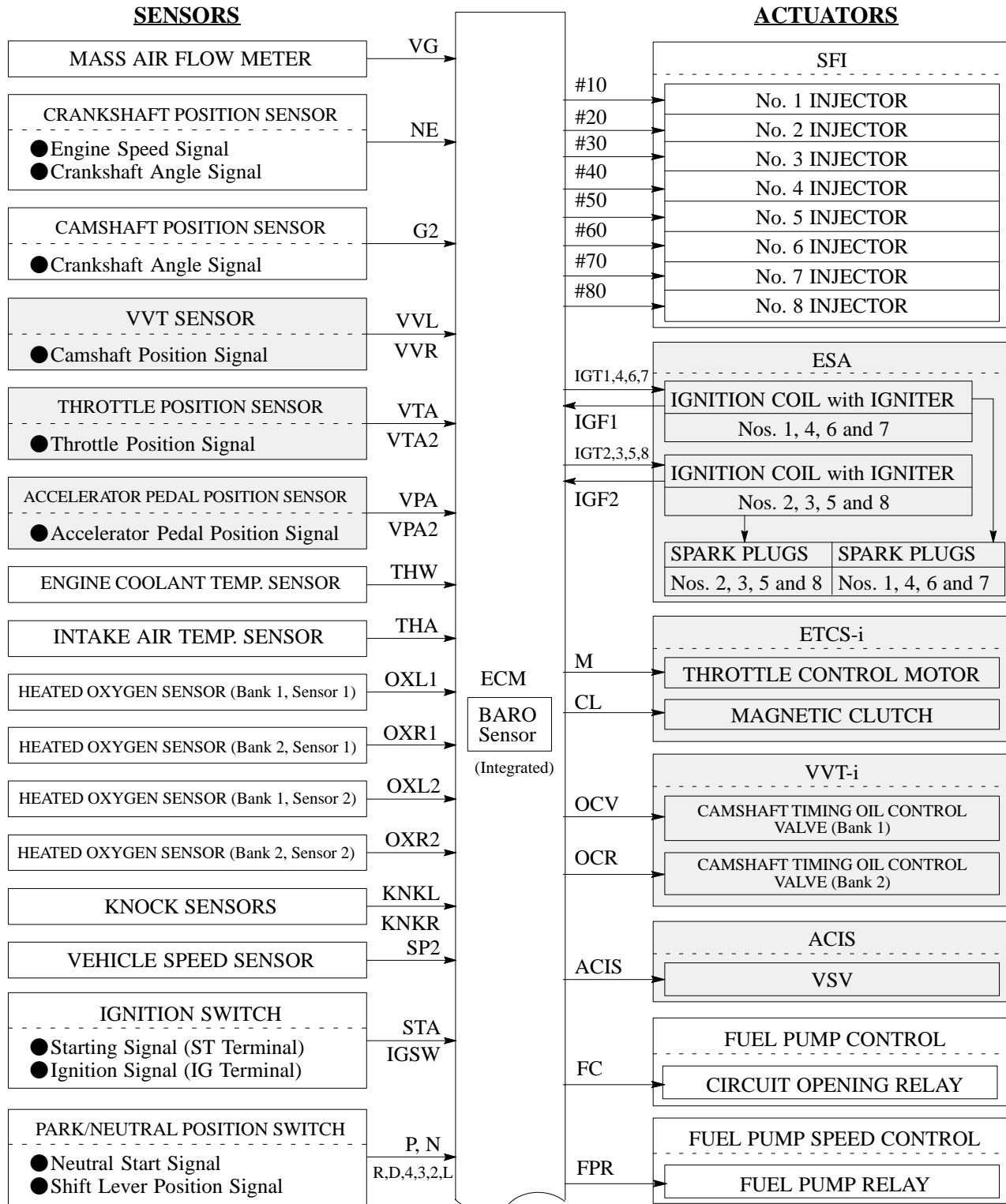

(Continued)

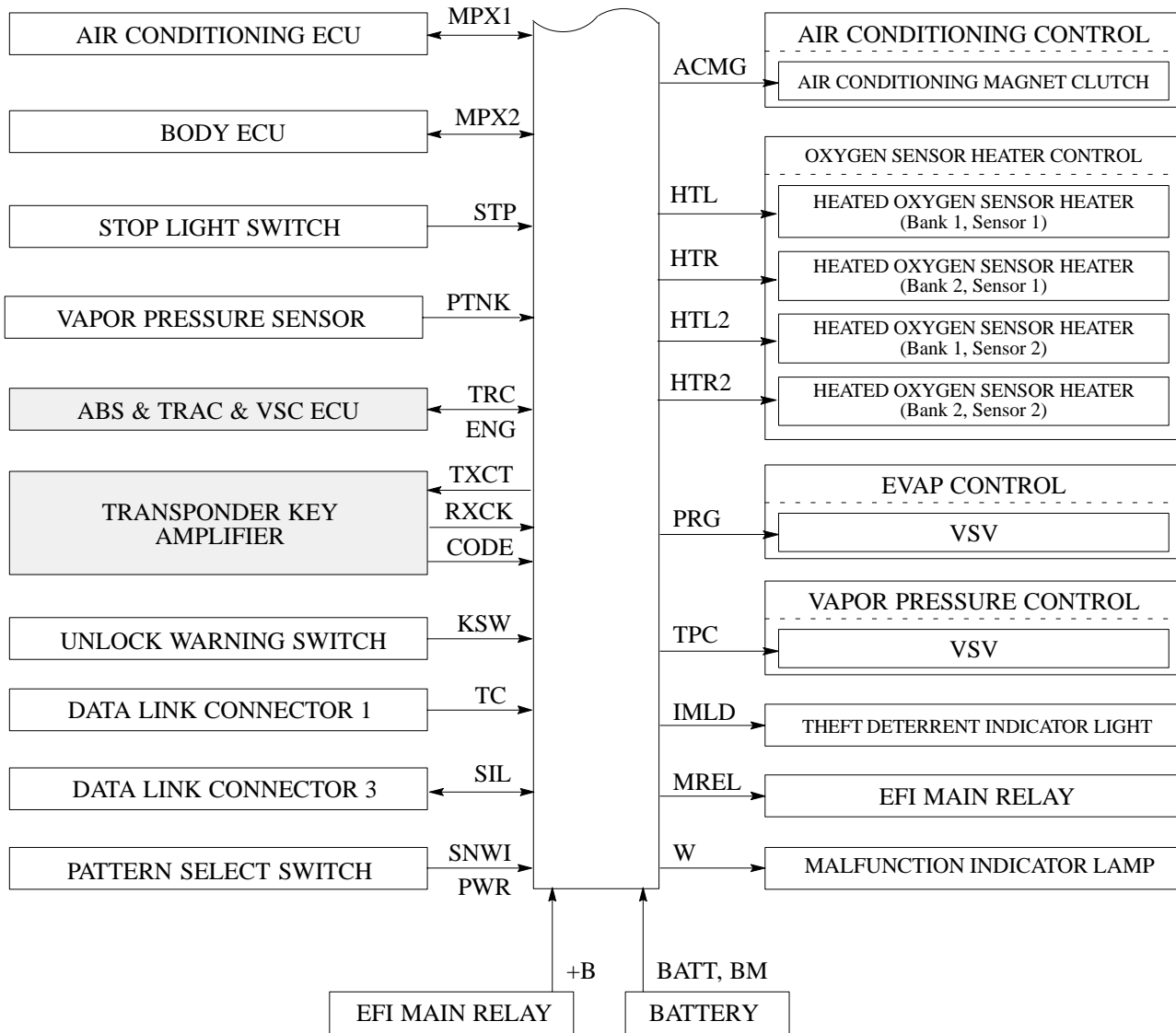

Engine Control System Diagram

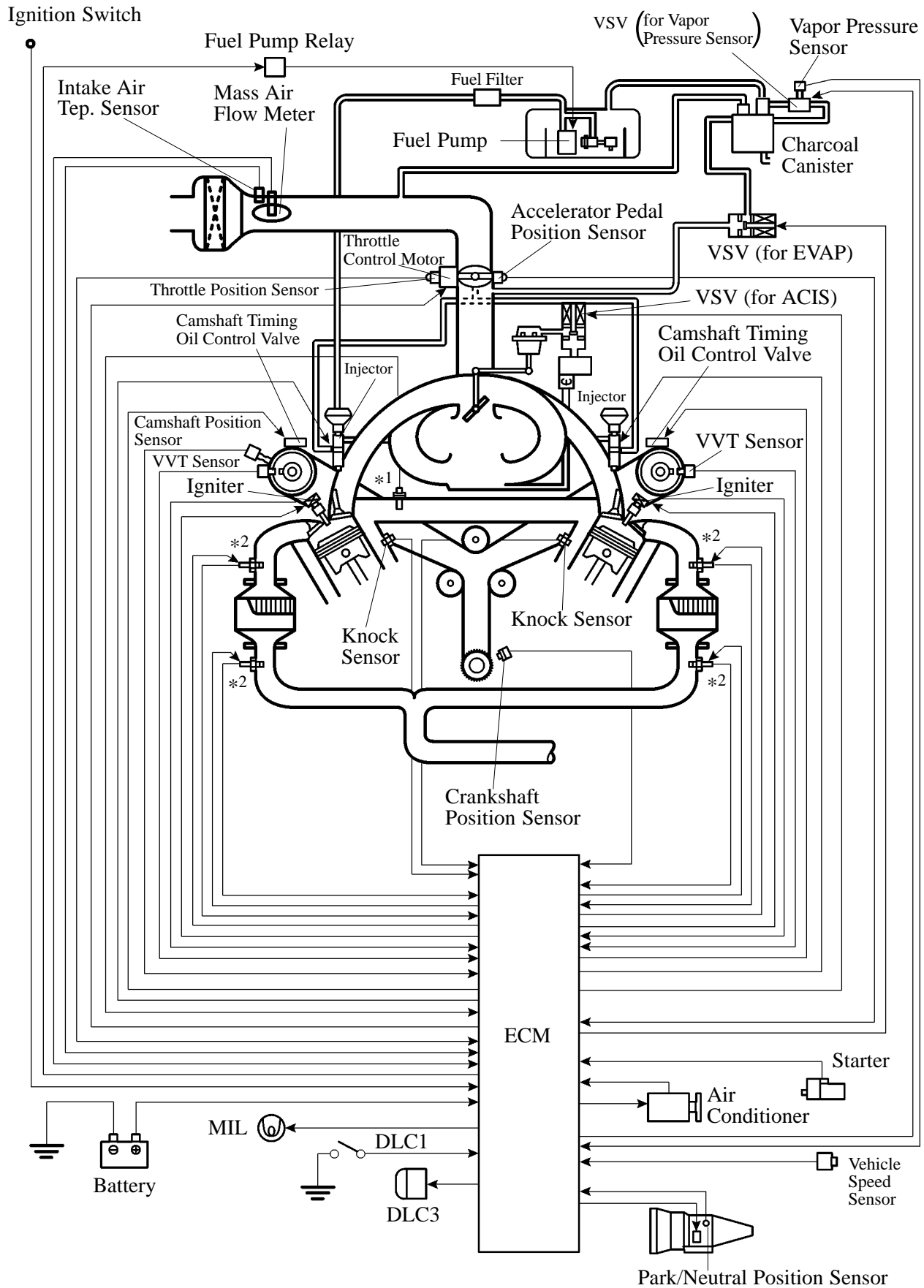

Main Components of Engine Control System

1) General

The following table compares the main components of the 1UZ-FE engine in the '98 LS400 and '97 LS400.

Components	1UZ-FE Engine	'98 LS400	'97 LS400
Mass Air Flow Meter		Hot-Wire Type	→
Crankshaft Position Sensor		Pick-Up Coil Type, 1	→
Camshaft Position Sensor		Pick-Up Coil Type, 1	Pick-Up Coil Type, 2
VVT Sensor		Pick-Up Coil Type, 2	—
Throttle Position Sensor		Linear Type, 2	Linear Type, 1
Accelerator Pedal Position Sensor		Linear Type, 2	—
Knock Sensor		Built-In Piezoelectric Type, 2	→
Oxygen Sensor		Heated Oxygen Sensor (Bank 1, Sensor 1) (Bank 2, Sensor 1) (Bank 1, Sensor 2) (Bank 2, Sensor 2)	→
Injector		4-Hole Type with Air Assist	2-Hole Type without Air Assist
IAC Valve		—	Step Motor Type

2) Mass Air Flow Meter

The hot wire type mass air flow meter has been changed to the plug-in type. Its basic operation is the same as that of the previous type.

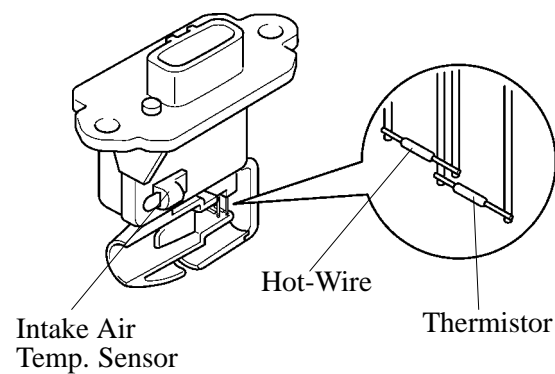

150EG29

3) Crankshaft Position Sensor

The timing rotor of the crankshaft position sensor has been changed from the previous 12 teeth to 34 teeth, with 2 teeth missing. It detects the crankshaft angle at 10° intervals.

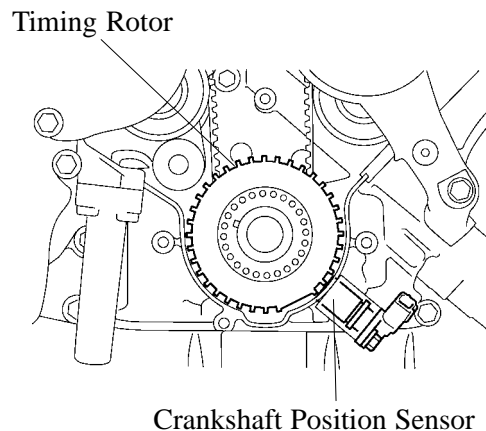

151EG18

4) Camshaft Position Sensor

The camshaft position sensor is mounted on the left bank cylinder head. To detect the camshaft position, a protrusion that is provided on the timing pulley is used to generate 1 pulse for every 2 revolutions of the crankshaft.

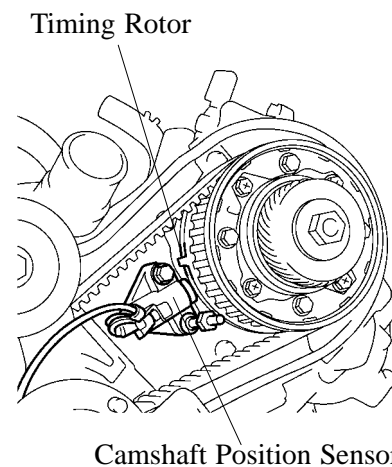

151EG19

5) VVT Sensor

A VVT sensor is mounted on the intake side of each cylinder head. To detect the camshaft position, a timing rotor that is provided on the intake camshaft is used to generate 3 pulses for every 2 revolutions of the crankshaft.

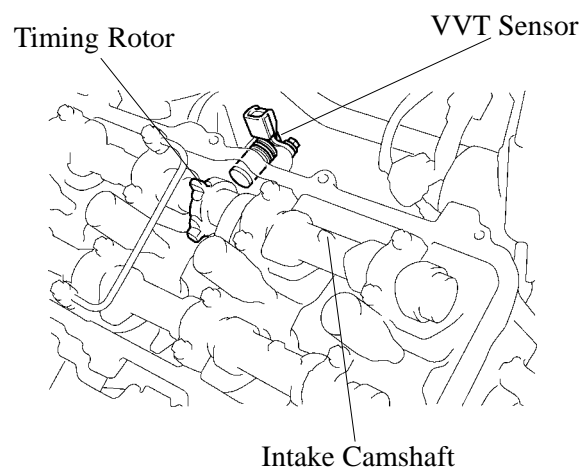

151EG20

VVT-i (Variable Valve Timing-intelligent) System

1) General

The VVT-i system is designed to control the intake camshaft within a wide range of 50° (of crankshaft angle) to provide a valve timing that is optimally suited to the engine condition, thus realizing improved torque in all the speed ranges and fuel economy, and exhaust emissions.

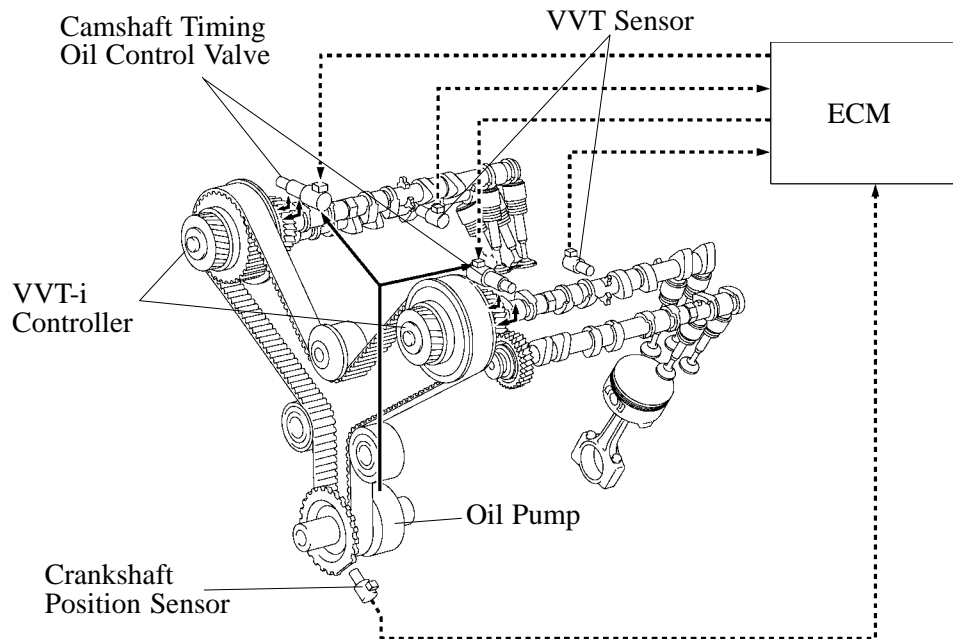

151EG27

2) Construction and Operation

a. VVT-i Controller

The VVT-i Controller comprises the outer gear that is driven by the timing belt, the inner gear that is affixed to the camshaft and a movable piston that is placed between the outer gear and inner gear. Having helical splines (twisted, vertical grooves) on its inner and outer periphery, the piston moves in the axial direction to shift the phase of the outer gear and inner gear, thus causing the valve timing to change continuously.

The VVT tube drives the exhaust camshaft via the scissors gear that is installed on the back.

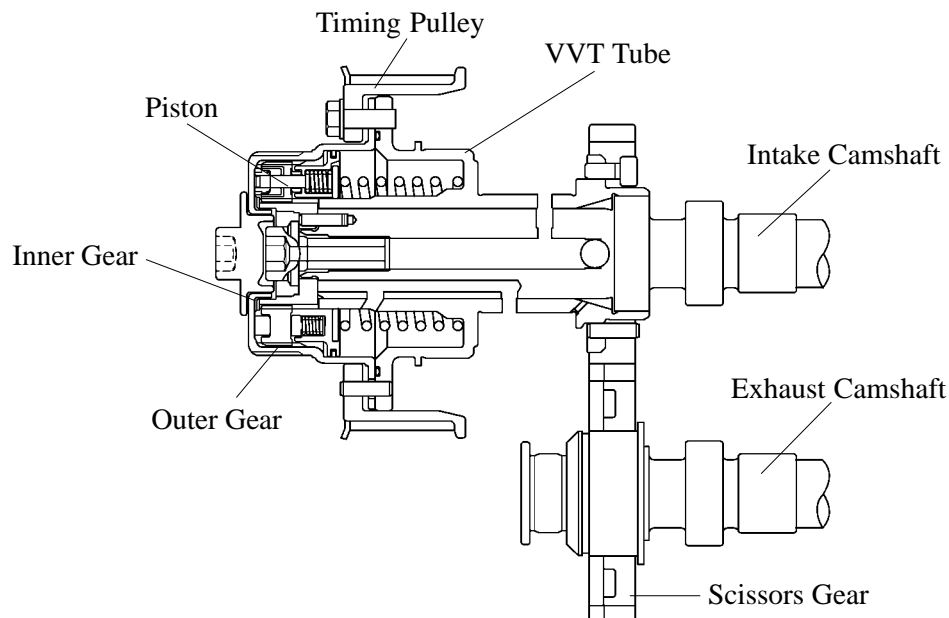

151EG29

b. Camshaft Timing Oil Control Valve

- The camshaft timing oil control valve controls the spool valve position in accordance with the command of the ECM thus allocating the hydraulic pressure that is applied to the intake camshaft timing pulley to the advance and the retard side. When the engine is stopped, the camshaft timing oil control valve is in the most retarded state.

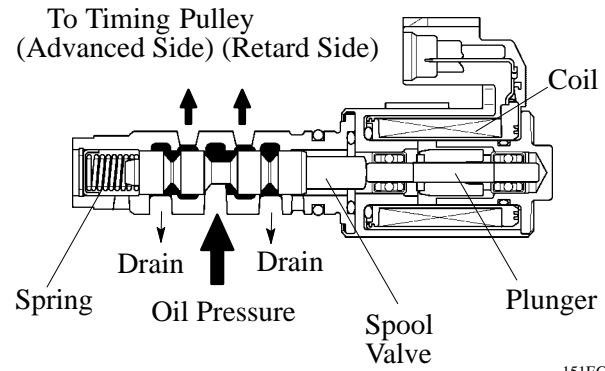

151EG28

- By the command of the ECM, when the camshaft timing oil control valve is in the position given in Fig. 1, hydraulic pressure is applied from the left side of the piston, which causes the piston to move to the right. Because of the twist in the helical splines that are cut out in the piston, the intake camshaft rotates in the advance direction in relation to the camshaft timing pulley. When the camshaft timing oil control valve is in the position given in Fig. 2, the piston moves to the left and rotates in the retard direction. Furthermore, the camshaft timing oil control valve shuts off the oil passages to maintain the hydraulic pressure at both sides of the piston, thus maintaining the phase at that position. This enables the phase to be set to a desired position.

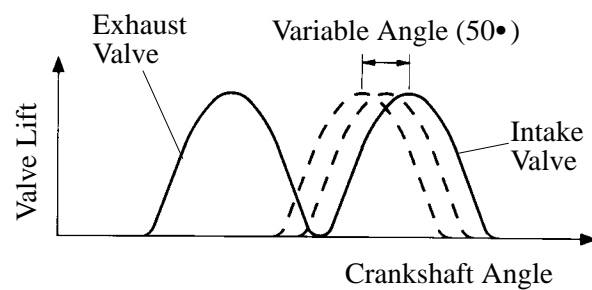

Valve Timing

150EG31

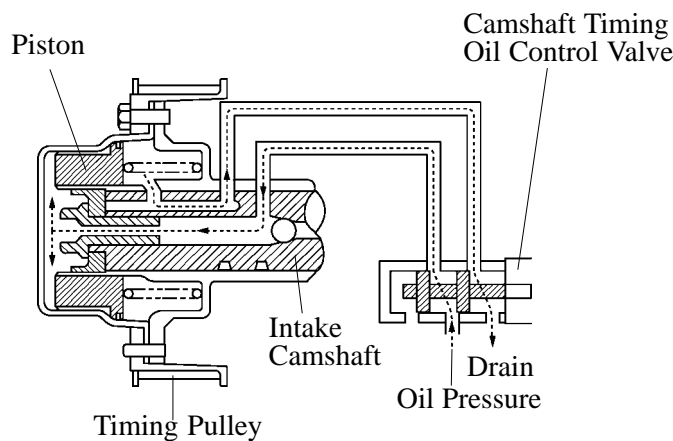

Fig. 1

151EG08

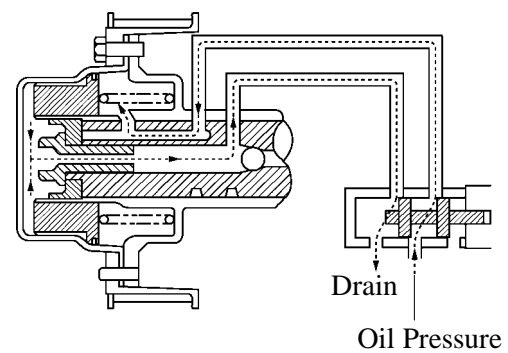

Fig. 2

151EG09

c. ECM

In proportion to the engine speed, intake air volume, throttle position and coolant temperature, the ECM searches an optimal valve timing under each driving condition and control the camshaft timing oil control valve. In addition, the ECM uses signal from the VVT sensors and the crankshaft position sensor to detect the actual valve timing, thus performing feedback control to achieve the target valve timing.

● Operation During Various Driving Conditions ◀

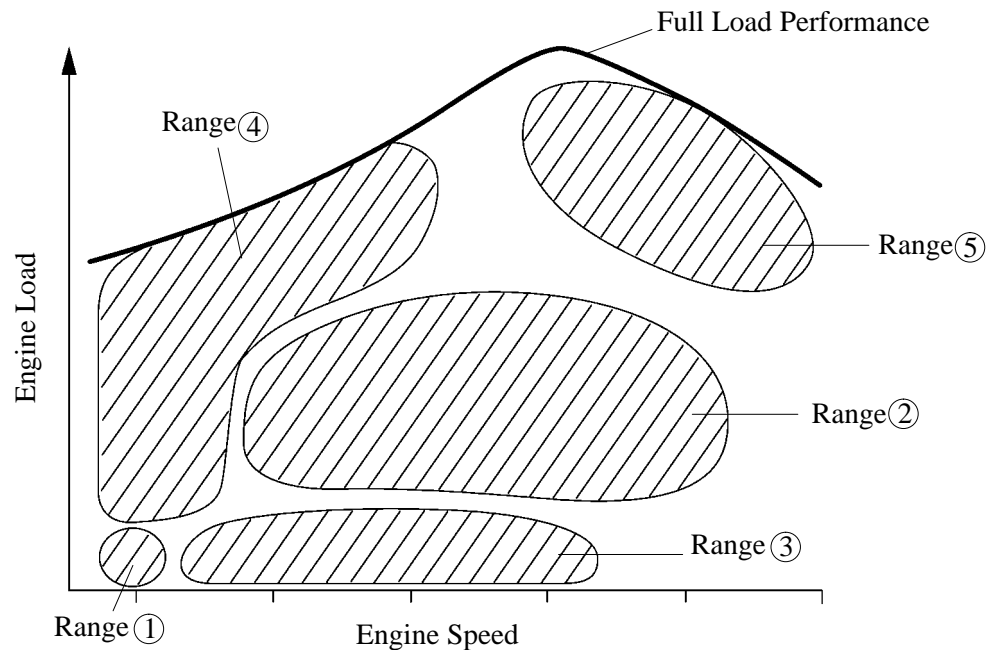

150EG74

Range	Conditions	Operation
①	Idle Operation	The valve timing is set to the advance angle 0° (most retarded angle), and because of the lack of overlap, the idle rpm is stabilized.
②	Medium load range	The valve timing is advanced to increase the amount valve overlap. Thus, the internal EGR rate is increased and the pumping loss is decreased resulting in improved fuel economy.
③	Low load range	The valve timing is retarded to decrease the amount of valve overlap, thus ensuring the engine's stability.
④	High load, low-to medium-speed range	The valve timing is advanced to advance the timing of the closing of the intake valve. The volumetric efficiency is thus improved resulting in improved low-to medium-speed range torque.
⑤	High load, high speed range	The valve timing is retarded to retard the timing of the closing of the intake valve resulting in improved volumetric in the high-speed range.
—	Engine started and stopped	When the engine is started and stopped, the valve timing is at the most retarded state.
—	High load at low temperature	The valve timing is fixed to the advanced side to quicken the timing of the intake valve closure, thus improving the volumetric efficiency and torque.

ETCS-i (Electronic Throttle Control System-intelligent)**1) General**

- The ETCS-i system, which realizes excellent throttle control in all the operating ranges, has been adopted.
- In the conventional throttle body, the throttle valve opening is determined invariably by the amount of the accelerator pedal effort. In contrast, the ETCS-i uses the ECM to calculate the optimal throttle valve opening that is appropriate for the respective driving condition and uses a throttle control motor to control the opening.
- The ETCS-i controls the ISC (Idle Speed Control) system, the cruise control system, and the VSC (Vehicle Skid Control).
- A duplicate system is provided to ensure a high level of reliability, and the system shuts off in case of an abnormal condition. Even when the system is shut off, the accelerator pedal can be used to operate the vehicle in the limp mode.

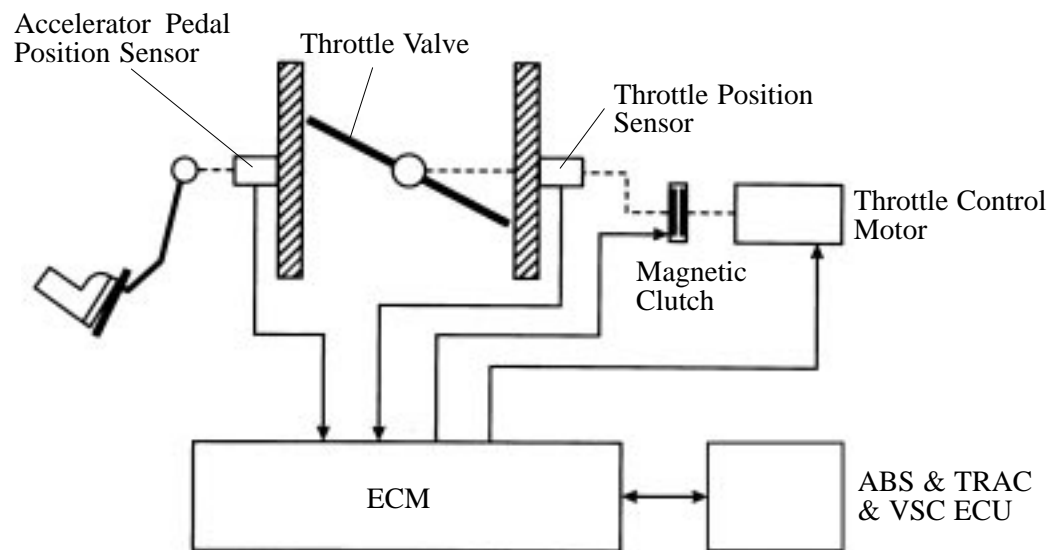

2) Construction

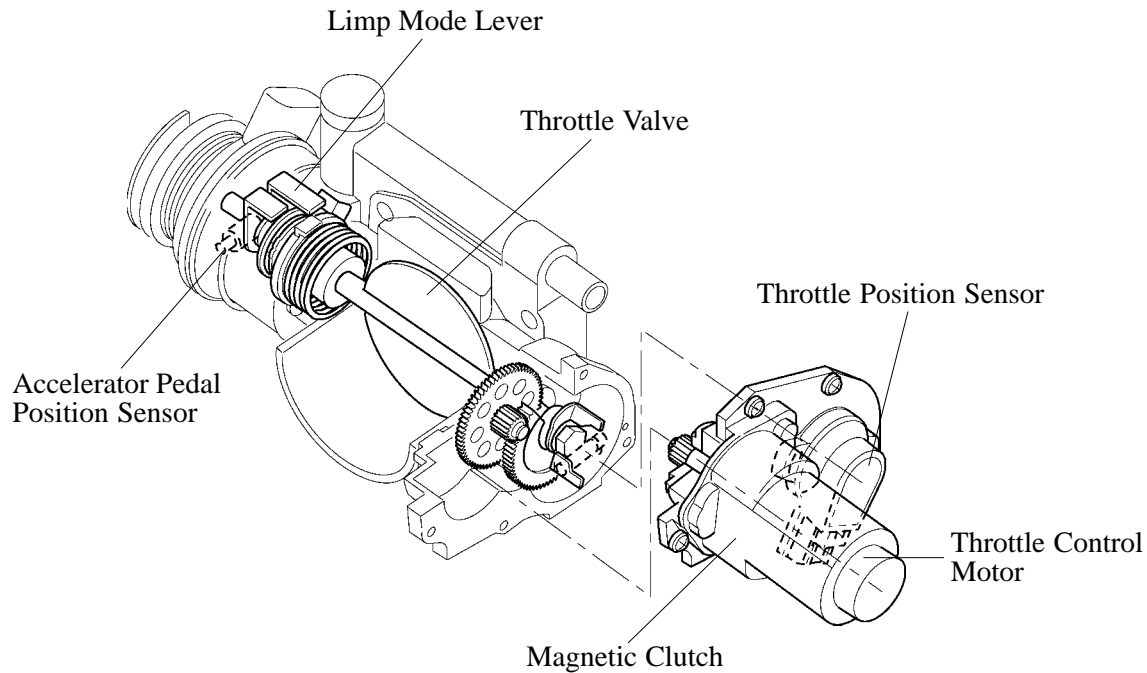

151EG01

a. Accelerator Pedal Position Sensor

The accelerator pedal position sensor, which is mounted on the throttle body, is integrated with the throttle lever, which is connected to the cable that extends from the accelerator pedal.

The accelerator pedal position sensor converts the amount of accelerator pedal effort into two types of electrical signals with distinct output characteristics. The signals are then input into the ECM.

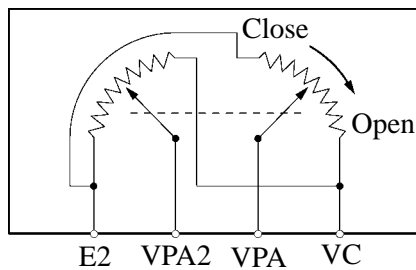

150EG40

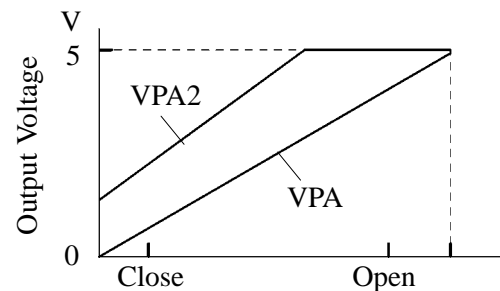

150EG39

Accelerator Pedal Depressed Angle

b. Throttle Position Sensor

The throttle position sensor converts the throttle valve opening into an electrical signal and inputs into the ECM. The output characteristics are the same as those of the accelerator position pedal sensor.

c. Throttle Control Motor

A DC motor with excellent response and minimal power consumption is used for the throttle control motor. The ECM performs the duty ratio control of the direction and the amperage of the current that flows to the throttle control motor in order to regulate the opening of the throttle valve.

d. Magnetic Clutch

Ordinarily, the magnetic clutch engages the clutch to enable the throttle control motor to open and close the throttle valve. In case that a malfunction occurs in the system, this clutch is disengaged to prevent the throttle control motor to open and close the throttle valve.

3) Operation

The ECM drives the throttle control motor by determining the target throttle valve opening in accordance with the respective operating condition.

- a. Non-linear Control
- b. Idle Speed Control
- c. Shift Shock Reduction Control
- d. TRAC Throttle Control
- e. VSC Coordination Control
- f. Cruise Control

a. Non-linear Control

- Controls the throttle to an optimal throttle valve opening that is appropriate for the driving condition such as the amount of the accelerator pedal effort and the engine rpm in order to realize excellent throttle control and comfort in all operating ranges.

- **Control Examples During Acceleration and Deceleration** ◀

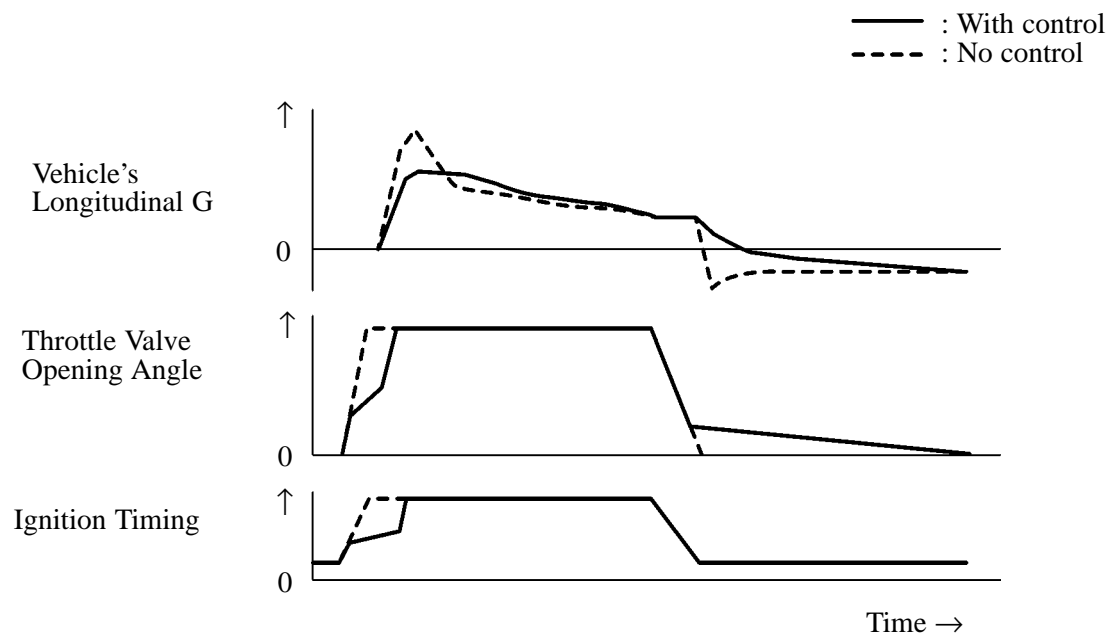

- In situations in which low- μ surface conditions can be anticipated, such as when driving in the snow, the throttle valve can be controlled to help vehicle stability while driving over the slippery surface. This is accomplished by turning ON the SNOW switch, which, in response to the amount of the accelerator pedal effort that is applied, reduces the engine output from that of the normal driving level.
- **Control Example During Startoff Acceleration in 1st Gear on Packed Snow Surface (TRAC OFF)** ◀

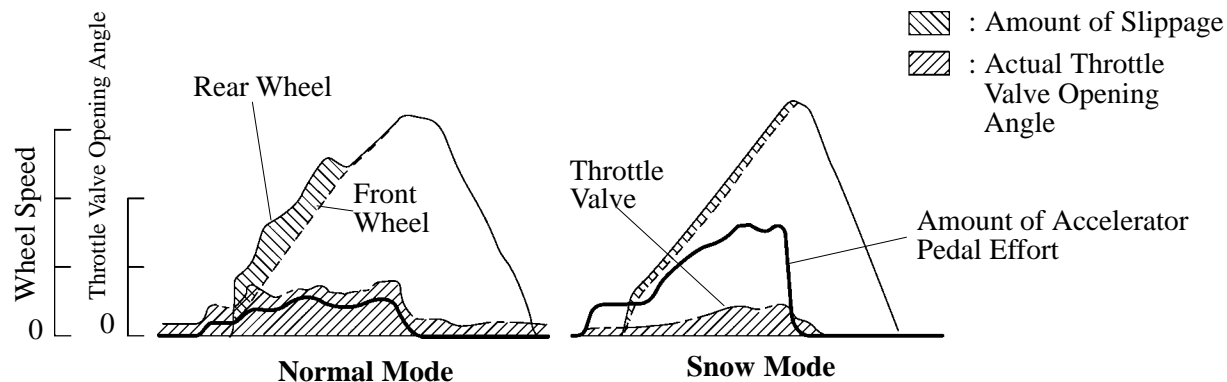

151EG40

b. Shift Shock Reduction Control

The throttle control is synchronized to the ECT (Electronically Controlled Transmission) control during the shifting of the transmission in order to reduce the shift shock.

c. Idle Speed Control

Previously, a step motor type IAC valve was used to perform idle speed control such as fast idle during cold operating conditions and idle-up. In conjunction with the adoption of the ETCS-i, idle speed control is now performed by the throttle control motor, which controls the throttle valve opening.

d. TRAC Throttle Control

As part of the TRAC system, the throttle valve is closed by a demand signal from the ABS & TRAC & VSC ECU if an excessive amount of slippage is created at a driving wheel, thus facilitating the vehicle in ensuring stability and driving force.

e. VSC Coordination Control

In order to bring the effectiveness of the VSC system control into full play, the throttle valve opening angle is controlled by effecting a coordination control with the ABS & TRAC & VSC ECU.

f. Cruise Control

Previously, the vehicle speed was controlled by the cruise control actuator, which opened and closed the throttle valve. Along with the adoption of the ETCS-i, the vehicle speed is now controlled by the throttle control motor, which controls the throttle valve.

4) Fail-Safe

If an abnormal condition occurs with the ETCS-i, the MIL illuminates to alert the driver. At the same time, the current to the throttle control motor and magnetic clutch are cut off in order not to operate the ETCS-i. This enables the return spring to close the throttle valve.

Even in this situation, the accelerator pedal can be used to operate the limp mode lever, which operates the throttle valve to enable the vehicle to be driven in the limp mode.

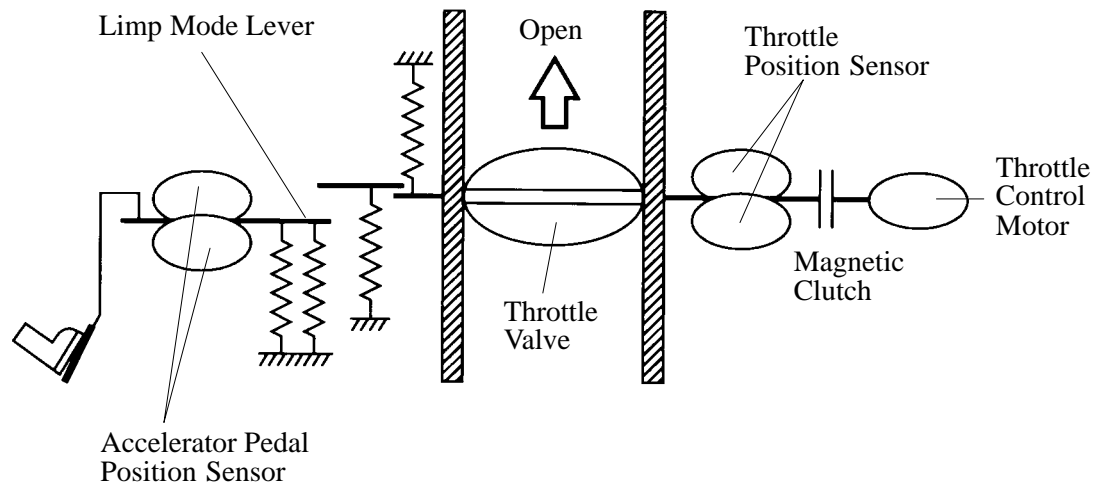

150EG42

5) Diagnosis

The diagnostic trouble codes can be output via DLC3 to an OBD-II scan tool or a hand-held tool. For details, refer to the '98 LS400 Repair Manual (Pub. No. RM578U).

ACIS (Acoustic Control Induction System)

1) General

The ACIS (Acoustic Control Induction System) is realized by using a bulkhead to divide the intake manifold into 2 stages, with an intake air control valve in the bulkhead being opened and closed to vary the effective length of the intake manifold in accordance with the engine speed and throttle valve opening angle. This increases the power output in all ranges from low to high speed.

- System Diagram ◀

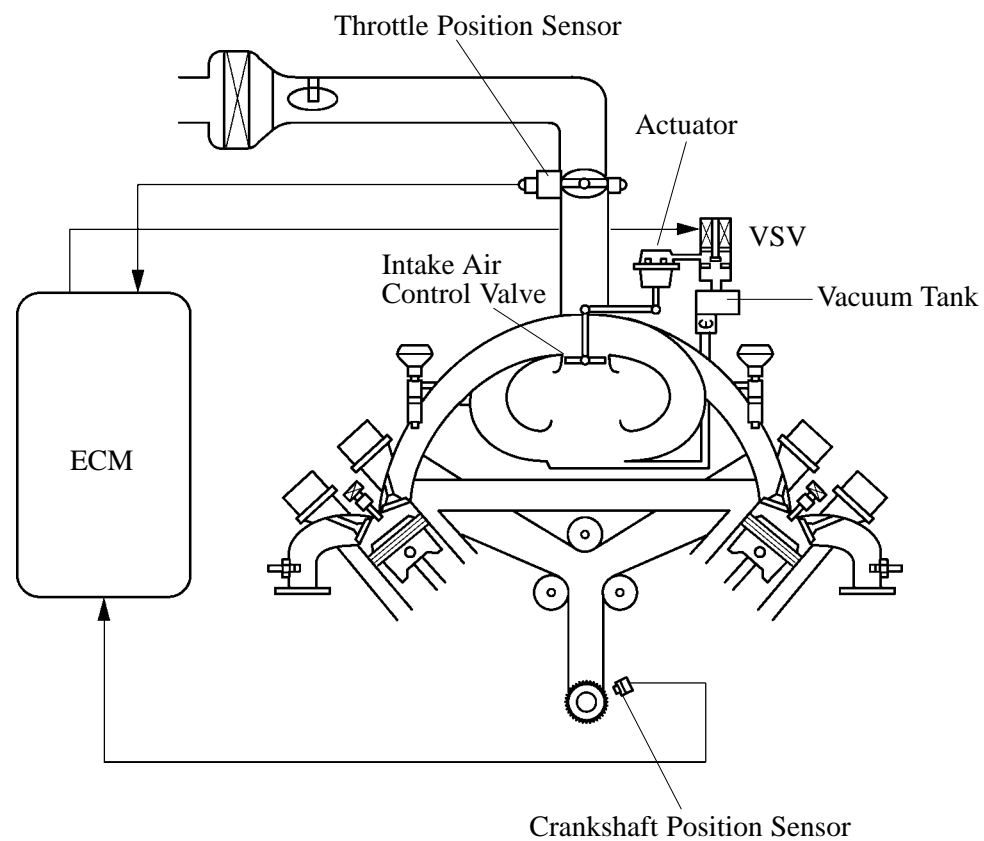

2) Construction

a. Intake Air Control Valve

The intake air control valve, which is provided in the middle of the intake manifold in the intake air chamber, opens and closes to change the effective length of the intake manifold in two stages.

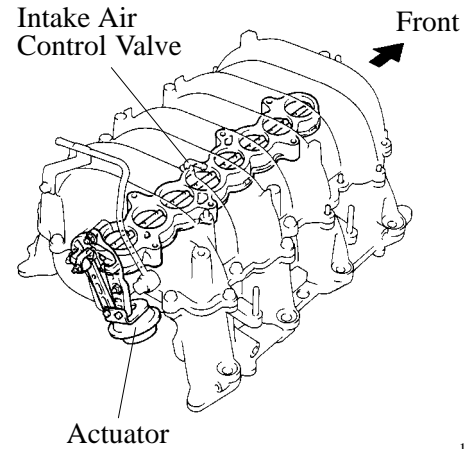

151EG11

b. VSV (Vacuum Switching Valve)

Controls the vacuum that is applied to the actuator by way of the signal (ACIS) that is output by the ECM.

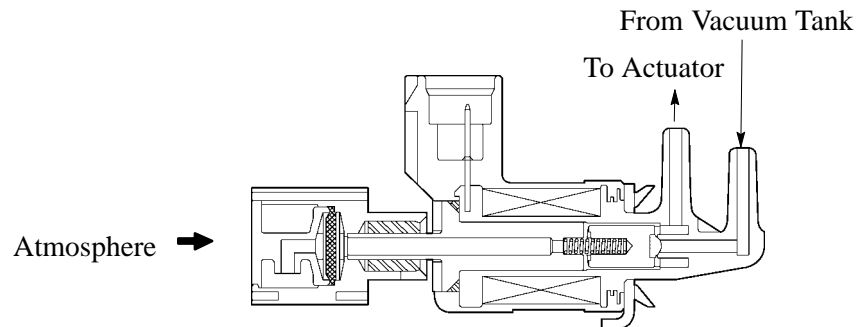

151EG42

c. Vacuum Tank

Equipped with an internal check valve, the vacuum tank stores the vacuum that is applied to the actuator in order to maintain the intake air control valve fully closed even during low-vacuum conditions.

3) Operation

a. When the Intake Control Valve Closes (VSV ON)

The ECM activates the VSV to match the longer pulsation cycle so that the negative pressure acts on the diaphragm chamber of the actuator. This closes the control valve. As a result, the effective length of the intake manifold is lengthened and the intake efficiency in the low-to-medium speed range is improved due to the dynamic effect of the intake air, thereby increasing the power output.

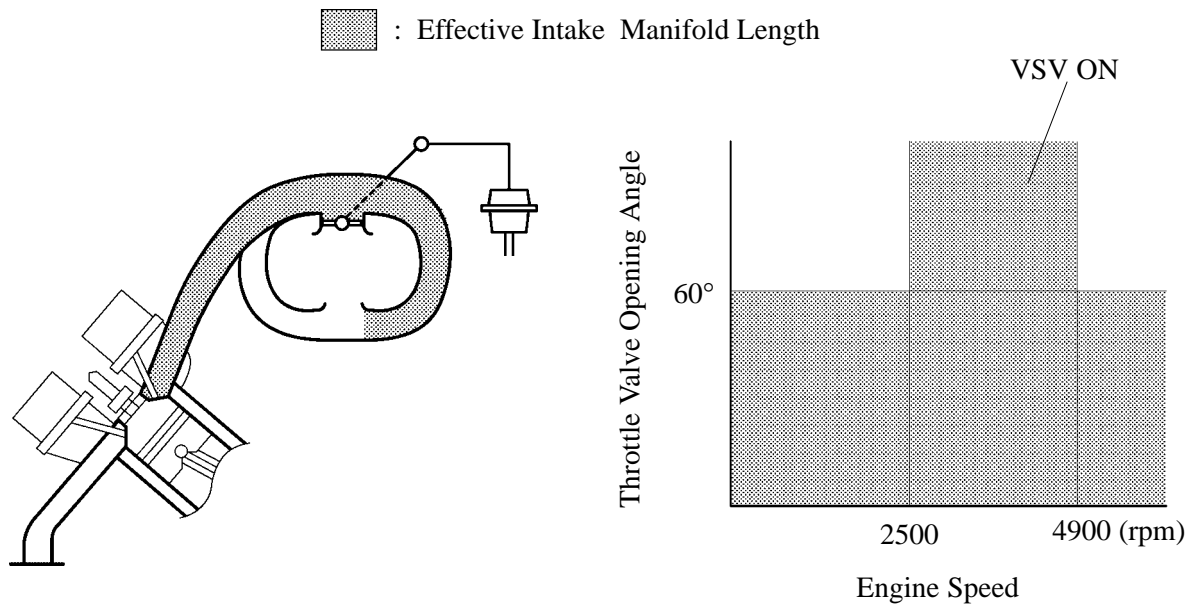

b. When the Intake Control Valve Open (VSV OFF)

The ECM deactivates the VSV to match the shorter pulsation cycle so that the atmospheric air is led into the diaphragm chamber of the actuator and opens the control valve. When the control valve is open, the effective length of the intake air chamber is shortened and the peak intake efficiency is shifted to the high engine speed range, thus providing greater output at high engine speeds.

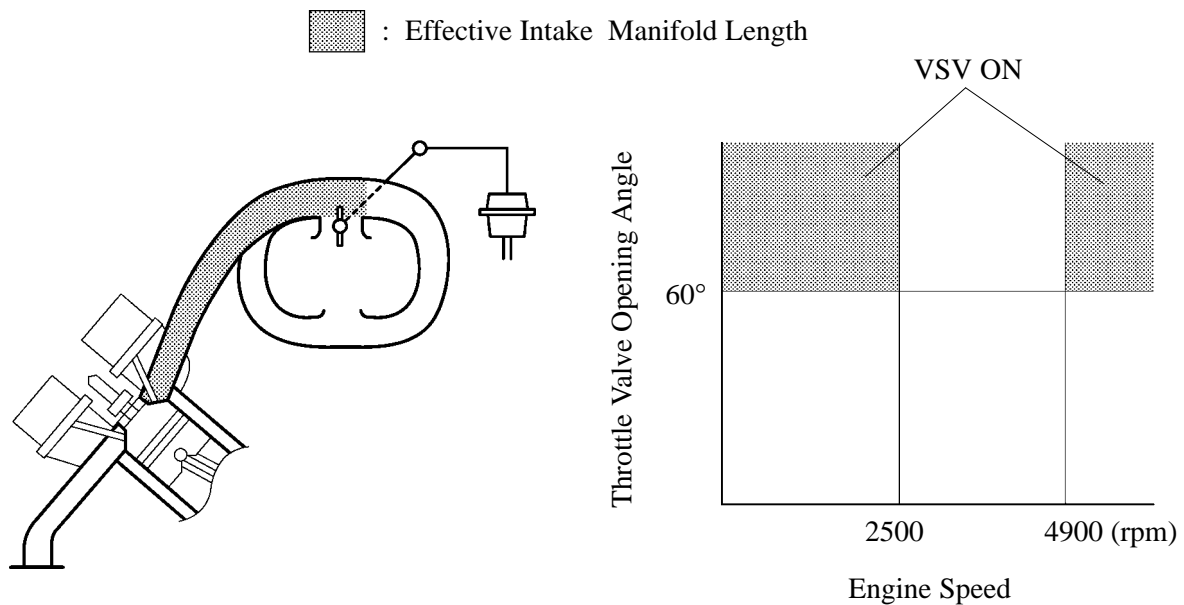

Function to Communicate with Multiplex Communication System

The ECM communicates with the meter ECU, air conditioning ECU, body ECU, etc., of the multiplex communication system.

The main output signals from the ECM are as follows:

- Signals from the Indicator Lights in the Speedometer (Oil Pressure Signal, Oil Level Signal and Generator L Terminal Signal)
- Engine Coolant Temp. Signal
- Engine Speed Signal
- Signals related to the Air Conditioning System (Refrigerant Pressure Signal and Compressor Speed Signal)

The main input signals to the ECM are as follows:

- Air Conditioning Signal
- Electrical Load Signal (Taillight and Rear Window Defogger System)

Engine Immobiliser System

The transponder key computer, which was previously separate, is now enclosed in the ECM. For details, see [page 167](#).

LS400

OUTLINE OF NEW FEATURES

Since its introduction, the LS400 has won a reputation as a high-performance and high-quality luxury sedan. The following improvements have been made for the 1999 model year.

1. Interior Equipment

A wood shift knob has been provided as standard equipment.

2. 1UZ-FE Engine

- A service port for inspecting the evaporative emission control system has been provided between the charcoal canister and VSV for EVAP. For details, see the General 1999 Features section.
- To support T-LEV, the amount of palladium, which is a constituent of the catalyst, has been increased in order to further reduce the amount of hydrocarbons (HC) that are contained in the exhaust gases.

3. Steering

An ultrasonic motor that features high torque characteristics has been adopted for the tilt motor and the telescopic motor, thus achieving a compact and lightweight steering column.

4. Lighting

The daytime running light system is standard equipment on models for the U.S.A. The basic construction and operation are the same as in the models for Canada.

5. Combination Meter

A blank mode, in which no cruise information appears on the multi-information display, has been provided.

6. SRS Airbag

- On models for Canada, the inflator for the airbag for the driver has been made compact.
- The silicon coating of the bag has been discontinued.

7. Outside Rearview Mirror

The activation of the reverse shift linked mirror function and the method for operating this function have been changed.

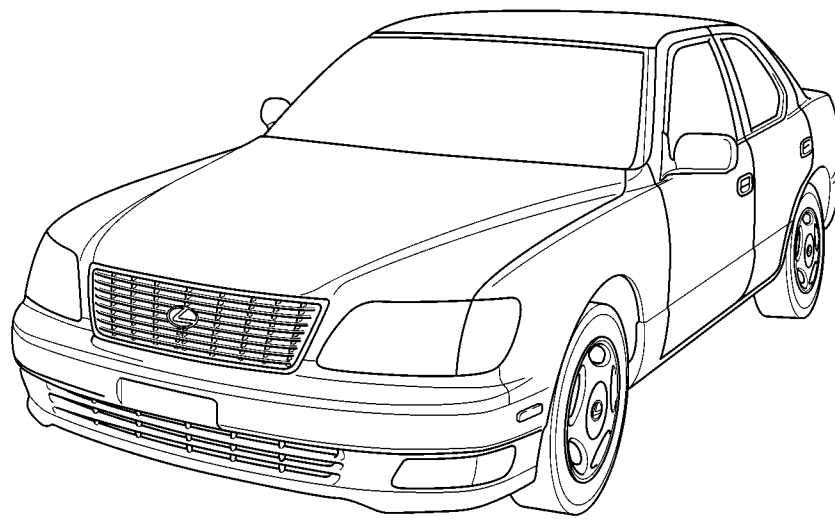

161LS07

NEW FEATURES

ENGINE

1. Fuel System

ORVR System

The ORVR (On-Board Refueling Vapor Recovery) is a system that uses a charcoal canister, which is provided onboard, to recover the fuel vapor that is generated during refueling. This reduces the discharge of fuel vapor into the atmosphere.

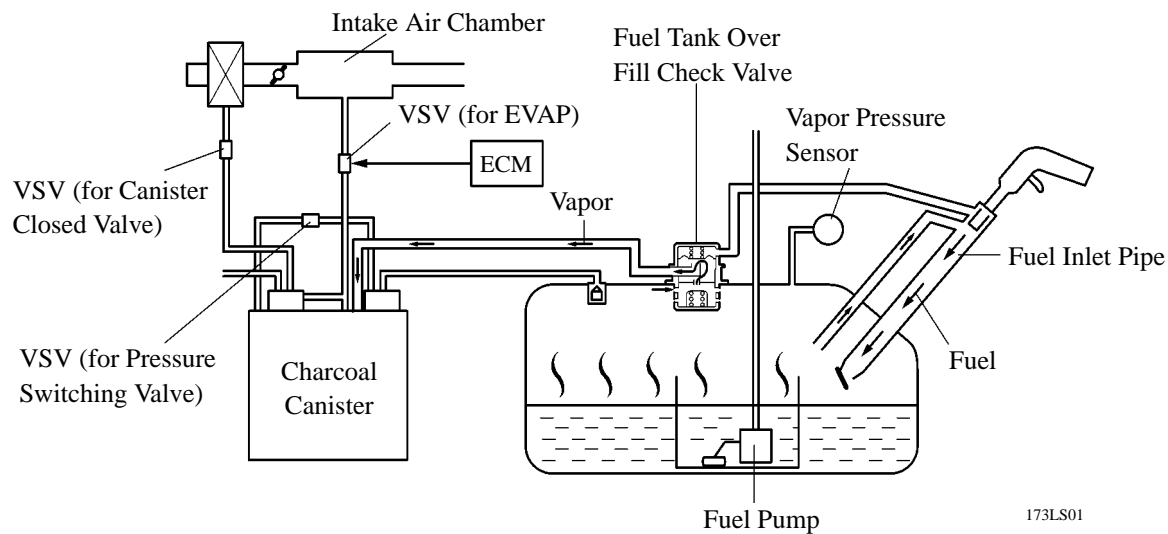

1) Operation

When the fuel tank cap is removed, atmosphere applies to the fuel tank over fill check valve's chamber A. Refueling causes the internal pressure of the fuel tank to increase, the vapor flows to the charcoal canister while maintaining valve B pressed, thus allowing the vapor to become absorbed by the charcoal canister. When the tank is full, valve C closes, thus shutting off the passage to the charcoal canister.

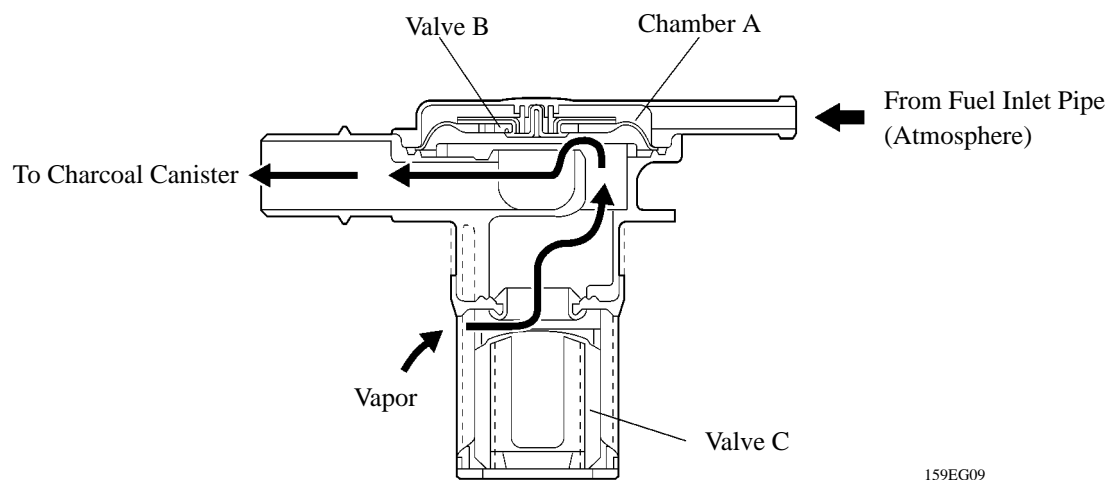

Fuel Tank Over Fill Check Valve

ENGINE

3UZ-FE ENGINE

- DESCRIPTION

On '01 LS430, base on the 1UZ-FE engine adopted on '00 LS400, 3UZ-FE engine of V8, 4.3-liter, 32-valve DOHC with the enlarged bore has been adopted.

This engine has adopted the VVT-i (Variable Valve Timing-intelligent) system, ACIS (Acoustic Control Induction System) and ETCS-i (Electronic Throttle Control System-intelligent), and these control functions have been optimized in order to realize the further improvement of the engine performance, fuel economy and to reduce exhaust emissions.

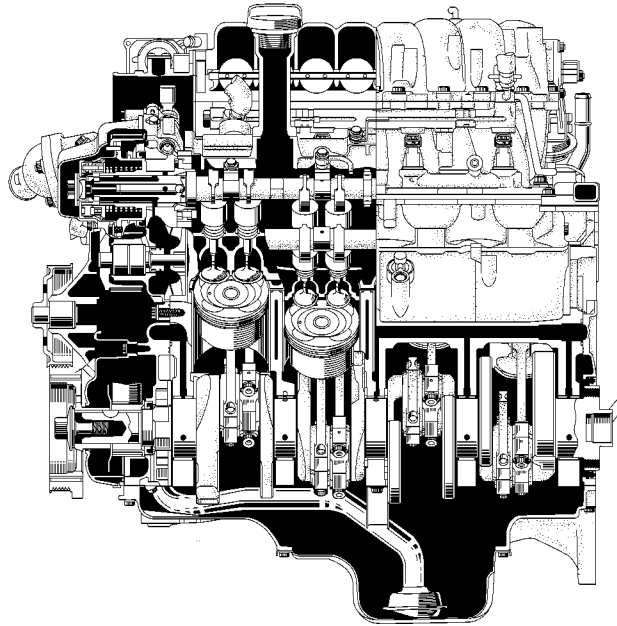

189EG18

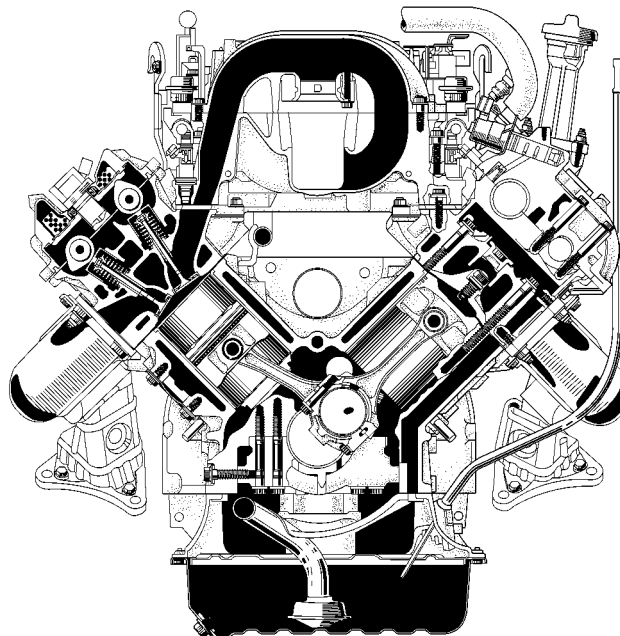

189EG19

34 • Engine Specifications ◀

Engine Type		3UZ-FE	1UZ-FE	
No. of Cyls. & Arrangement		8-Cylinder, V Type	→	
Valve Mechanism		32-Valve DOHC, Belt & Gear Drive	→	
Combustion Chamber		Pentroof Type	→	
Manifolds		Cross-Flow	→	
Fuel System		SFI	→	
Displacement	cm ³ (cu. in.)	4293 (261.9)	3969 (242.1)	
Bore × Stroke	mm (in.)	91.0 × 82.5 (3.58 × 3.25)	87.5 × 82.5 (3.44 × 3.25)	
Compression Ratio		10.5 : 1	→	
Max. Output	[SAE-NET]	216 kW @ 5600 rpm (290 HP @ 5600 rpm)	216 kW @ 6000 rpm (290 HP @ 6000 rpm)	
Max. Torque	[SAE-NET]	434 N·m @ 3400 rpm (320 ft·lbf @ 3400 rpm)	407 N·m @ 4000 rpm (300 ft·lbf @ 4000 rpm)	
Valve Timing	Intake	Open	-14° ~ 31° BTDC	-14° ~ 36° BTDC
		Close	64° ~ 19° ABDC	64° ~ 14° ABDC
	Exhaust	Open	46° BBDC	→
		Close	3° ATDC	→
Fuel Octane Number	RON	95 or more	→	
Oil Grade		API SJ, EC or ILSAC	→	

• Performance Curve ◀

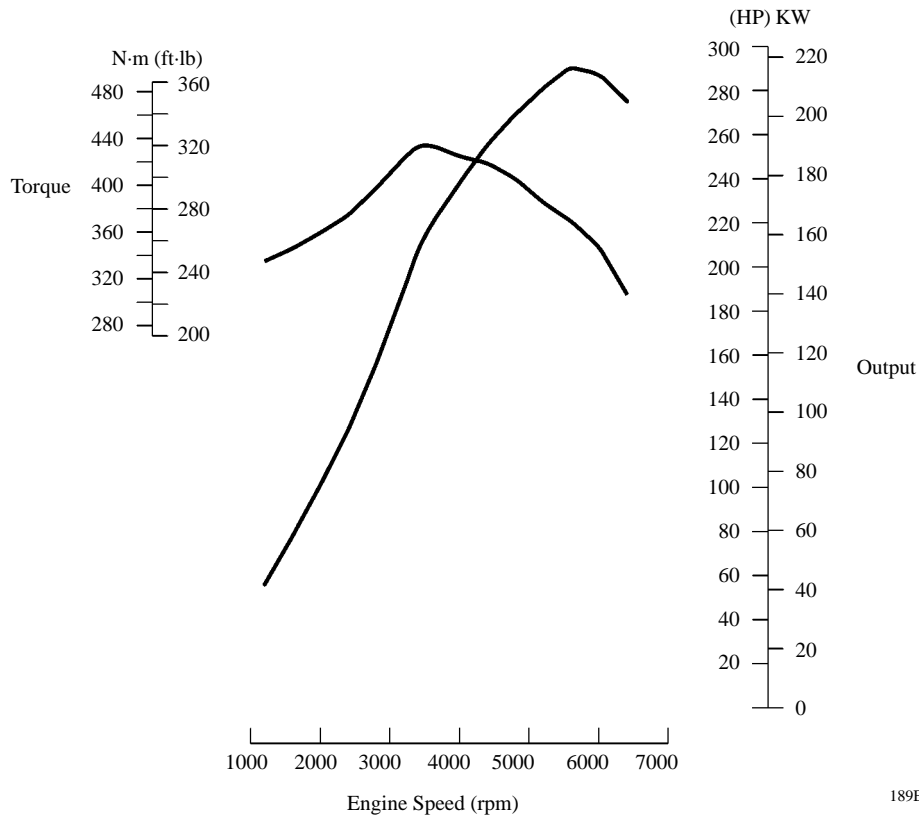

• MAJOR DIFFERENCES

The major differences between the new 3UZ-FE engine on the '01 LS430 and the 1UZ-FE engine on the '00 LS400 are the following:

System	Features
Engine Proper	<ul style="list-style-type: none"> • The water passage outside of the cylinder head bolts has been changed to improve the flow of the water around the valve seats, thus reducing the temperature of the combustion chamber. • The cylinder bore has been increased in size, and the thickness of the liner has been decreased. • The shape of the cylinder head gasket has been changed in conjunction with the increase in the size of the cylinder bore. • The material strength of the cylinder head bolts has been changed to increase their axial tension. As a result, the head gaskets tightening has been improved. • The piston diameter has been increased in size, and its shape has been optimized to achieve weight reduction. • The material of the inner surface of the bushing in the small end of the connecting rod has been changed from lead bronze alloy to phosphor bronze alloy. • The material of the sliding surface of the crankshaft bearing has been changed from kelmet to aluminum alloy.
Cooling System	<ul style="list-style-type: none"> • An electric cooling fan system has been adopted. • The shape of the water inlet housing has been optimized to increase the water flow and to achieve weight reduction.
Intake and Exhaust System	<ul style="list-style-type: none"> • A resonator and a tuning hole have been provided in the air cleaner inlet to reduce the amount of intake air sound. • The air cleaner case has been increased in size to reduce the amount of intake air sound, and the construction of the air cleaner element has been optimized to achieve weight reduction. • A stainless steel exhaust manifold with a single-pipe construction has been adopted. As a result, the warm-up performance of the TWC (Three-way Catalytic Converter) has been improved. • Two TWCs (Three-way Catalytic Converters) have been provided in the front, and one in the center. • Ultra thin-wall, high-cell ceramic type TWCs have been adopted. • A link-less type throttle body has been adopted.
Fuel System	<ul style="list-style-type: none"> • A saddle-shaped fuel tank has been adopted. • A compact fuel pump in which a fuel filter, pressure regulator and jet pump are integrated in the module fuel pump assembly has been adopted. • The charcoal canister has been relocated.
Ignition System	<p>The construction of the ignition coil has been optimized to achieve a compact and lightweight configuration.</p>

	<ul style="list-style-type: none">• Torque activated power train control has been newly adopted for the control of ETCS-i. Also, the fail-safe control has been reconsidered with the adoption of the link-less type throttle body.
Engine Control System	<ul style="list-style-type: none">• The ECM steplessly controls the speeds of the two fans along with the adoption of an electric cooling fan system.• A fuel cut control is adopted to stop the fuel pump when the airbag is deployed at the front or side collision.• A DTC (Diagnostic Trouble Code) has been newly adopted for indicating a thermostat malfunction.
Others	The ECM has been installed in the engine compartment for improved serviceability.

1. Cylinder Head

- The cylinder head is made of aluminum and has intake and exhaust ports in a cross-flow arrangement. The intake ports are on the inside and the exhaust ports on the outside of the left and right banks respectively.
- The pitch of the intake and exhaust camshafts is shortened and the valve angle is narrowed to 21° 33'.
- The left and right banks of cylinder heads are common in configuration.

NOTICE

When the cylinder heads are disassembled for servicing, be sure to assemble each cylinder head to the correct right or left bank. The camshaft may seize if they are assembled incorrectly.

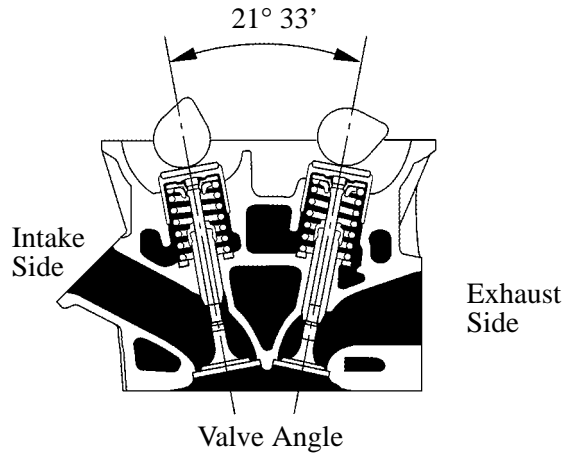

188EG05

2. Cylinder Head Gasket

The same type of (4-layer) steel laminate cylinder head gasket used in the 1UZ-FE engine on the '00 LS400 is used in the 3UZ-FE engine on the '01 LS430, except that its shape has been slightly changed in accordance with the increased cylinder displacement of the new engine.

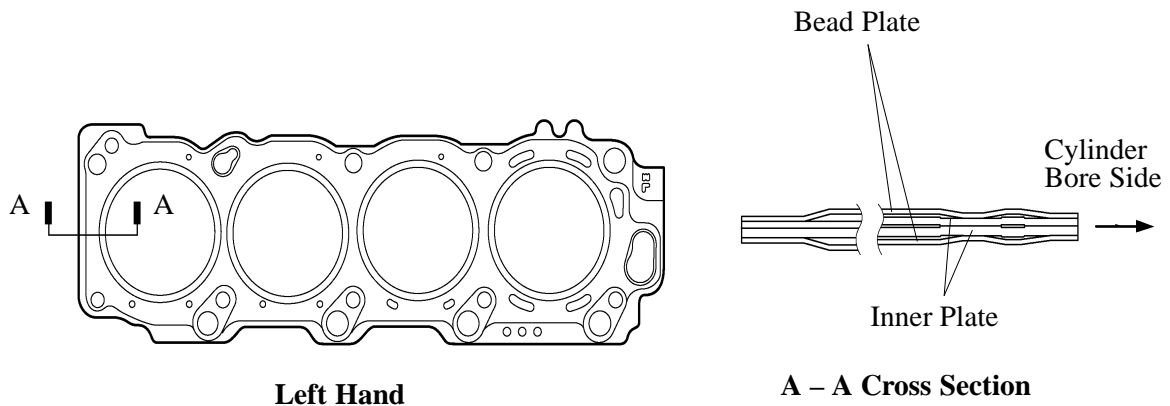

189EG40

38. Cylinder Block

- The cylinder block has a bank angle of 90°, a bank offset of 21 mm (0.827 in.) and a bore pitch of 105.5 mm (4.15 in.), resulting in a compact block in its length and width even for its displacement.
- Light weight aluminum alloy is used for the cylinder block.
- In contrast to the 1UZ-FE engine on the '00 LS400, the liner thickness in the 3UZ-FE engine on the '01 LS430 has been changed from 2 mm (0.08 in.) to 1.5 mm (0.06 in.) to achieve weight reduction and improved cooling performance. It is not possible to bore this liner due to its thinness. The thickness of the wall has been changed from 5.5 mm (0.22 in.) to 6.5 mm (0.26 in.), and the shape of the water passage between the bores has been optimized to improve both cooling performance and rigidity.

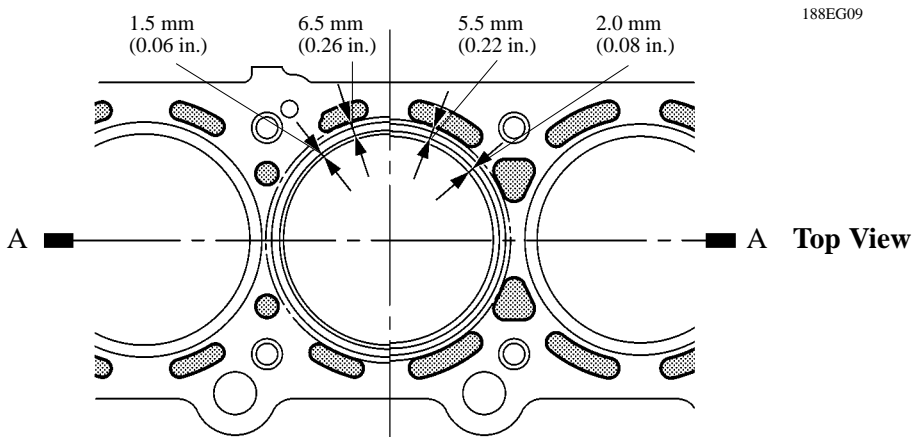
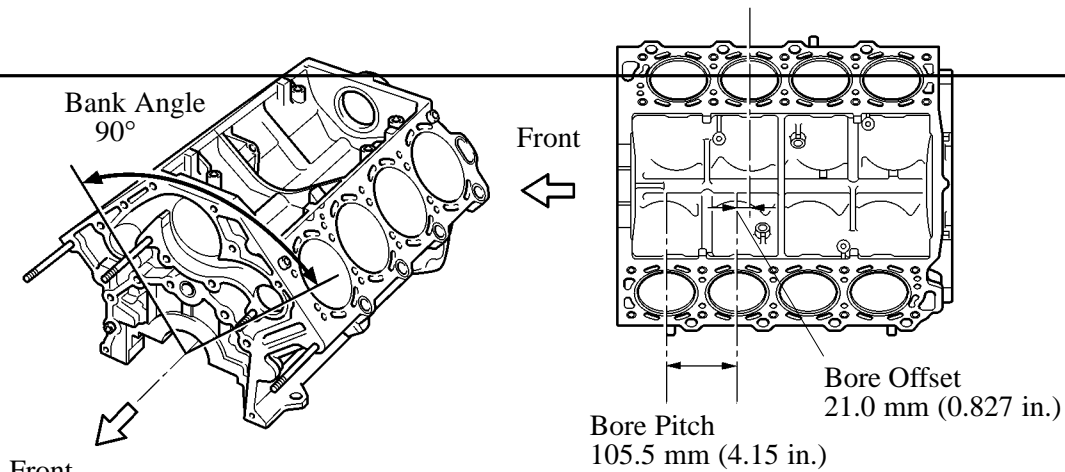

188EG09

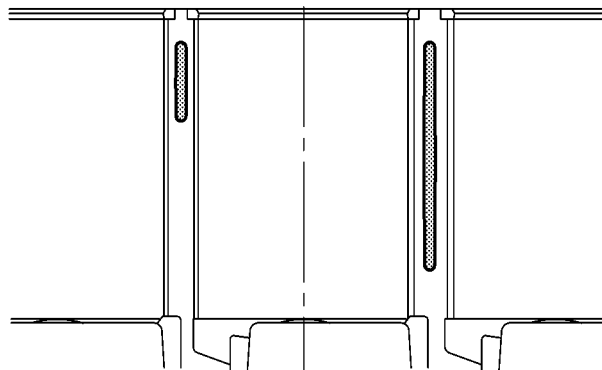

188EG10

'01 3UZ-FE

'00 1UZ-FE

A - A Cross Section

4. Piston

- The piston head portion has adopted a taper squish shape to improve the fuel combustion efficiency.
- The sliding surface of the piston skirt has been coated with resin to reduce the amount of friction loss.
- Full floating type piston pins are used.
- By increasing the machining precision of the cylinder bore diameter, the outer diameter of the piston has been made into one type.
- In contrast to the 1UZ-FE engine on the '00 LS400, the placement position of the piston rings has been slightly raised in the 3UZ-FE engine on the '01 LS430 in order to reduce the area in which unburned fuel is likely to accumulate during the combustion process. Furthermore, the squish area in the thrust direction of the piston head has been discontinued and the combustion chamber has been made shallower in order to further improve the combustion efficiency, thus improving fuel economy.

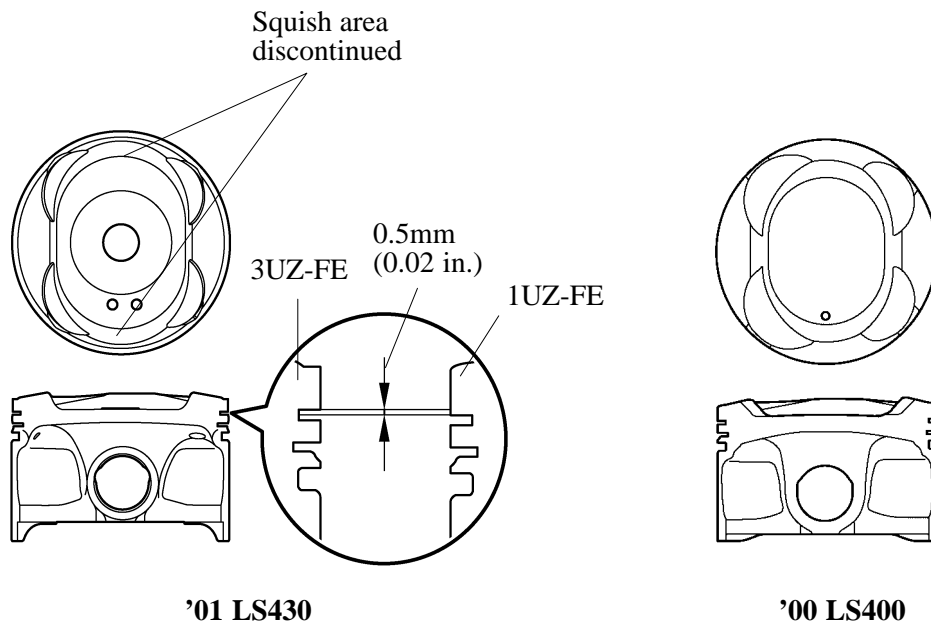

5. Connecting Rod

- The sintered and forged connecting rod is highly rigid and has little weight fluctuation.
- A weight-adjusting boss is provided at the big end to reduce fluctuation of weight and balance the engine assembly.
- In contrast to the 1UZ-FE engine on the '00 LS400, the material of the inner surface of the bushing in the small end of the connecting rod in the 3UZ-FE engine on the '01 LS430 has been changed from lead bronze alloy to phosphor bronze alloy to reduce the lead quantity and to further improve the wear resistance.
- The connecting rod cap is held by plastic region tightening bolts.

NOTE: When reusing the connecting rod cap bolts, if the diameter at the thread is less than 7.0 mm (0.275 in.), it is necessary to replace them with new ones.

- The connecting rods for the right and left banks are placed in opposite directions with the outer marks facing the crankshaft.

41
Phosphor
Bronze

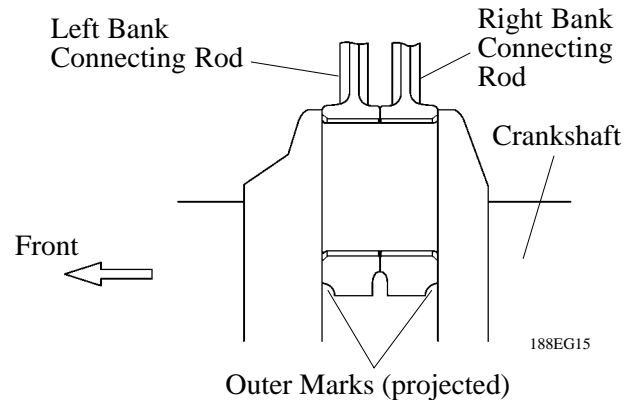
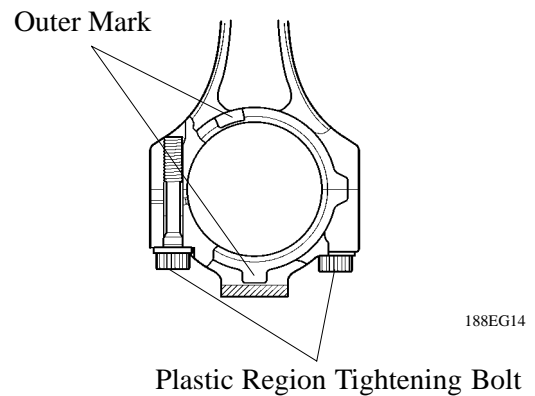
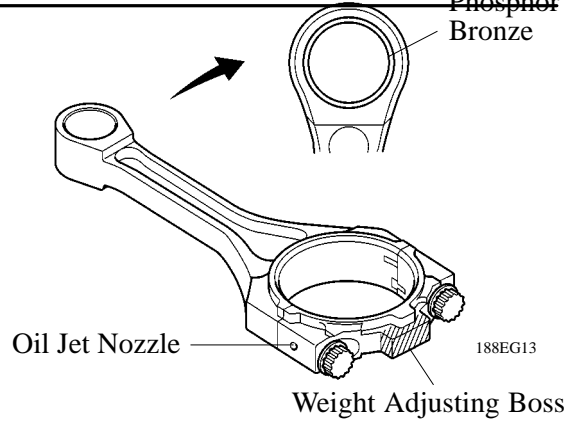

4.6. Crankshaft and Crankshaft Bearings

- A forged crankshaft with five main journals, four connecting rod pins and eight balance weights is used.
- Connecting rod pins and journals are induction-hardened to ensure an added reliability.

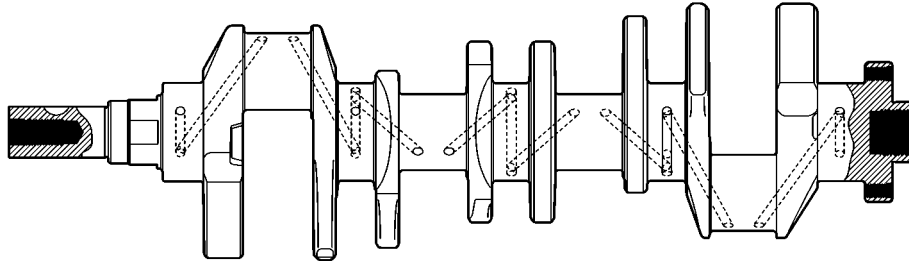

188EG16

- In contrast to the 1UZ-FE engine on the '00 LS400, the material of the sliding surface of the crankshaft bearing in the 3UZ-FE engine on the '01 LS430 has been changed from kelmet to aluminum alloy to discontinue the use of lead and to further enhance the engine's quiet operation.

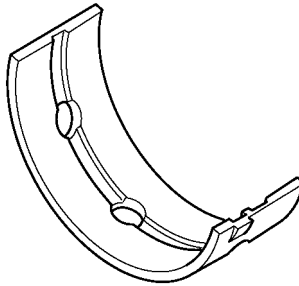

188EG17

- Crankshaft bearings are selected carefully according to the measured diameters of the crank journal and cylinder block journal holes.

NOTE: The diameter of the crank journal and the cylinder block journal hole is indicated at the places shown below.

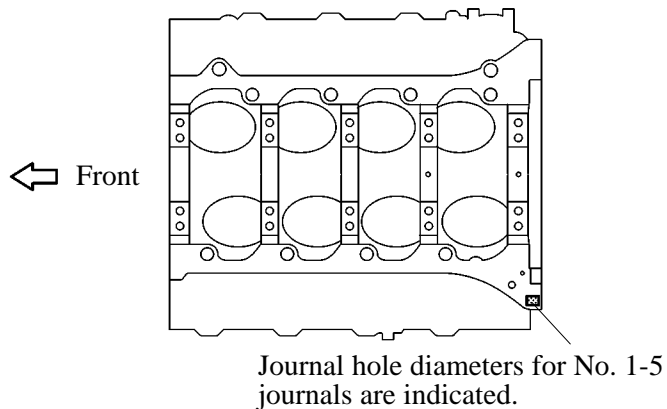
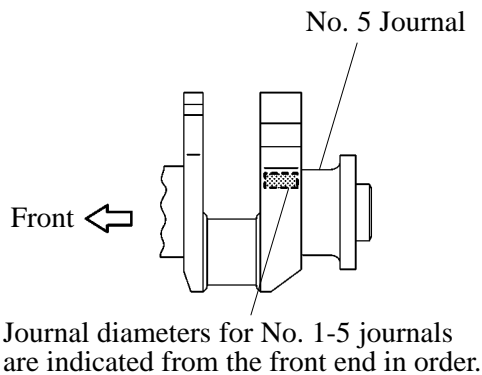

Bottom View of the Cylinder Block

188EG18

NOTE: Numbers of the crankshaft and pistons are shown on the right side.

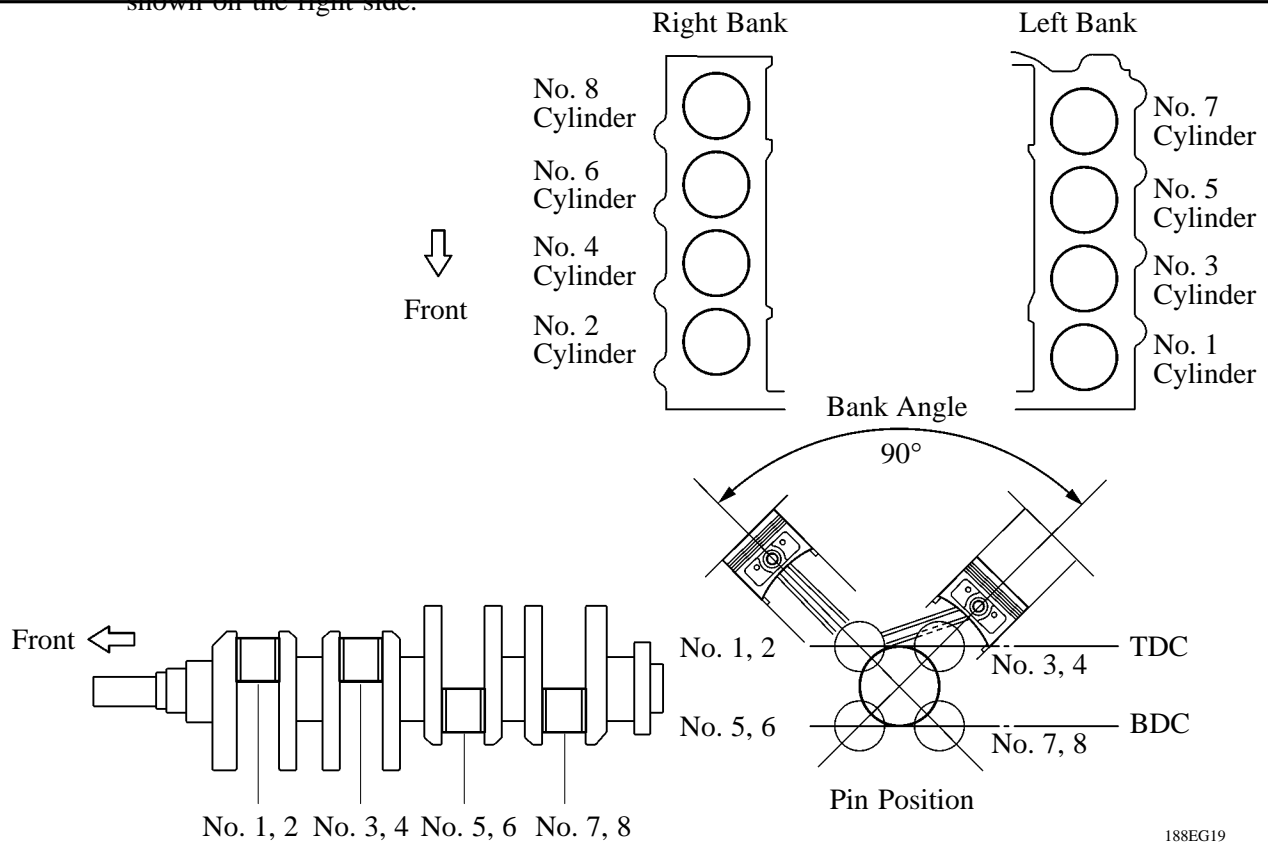

188EG19

Crankshaft angles and engine strokes (intake, compression, combustion and exhaust) are shown in the table below. The firing order is 1 - 8 - 4 - 3 - 6 - 5 - 7 - 2.

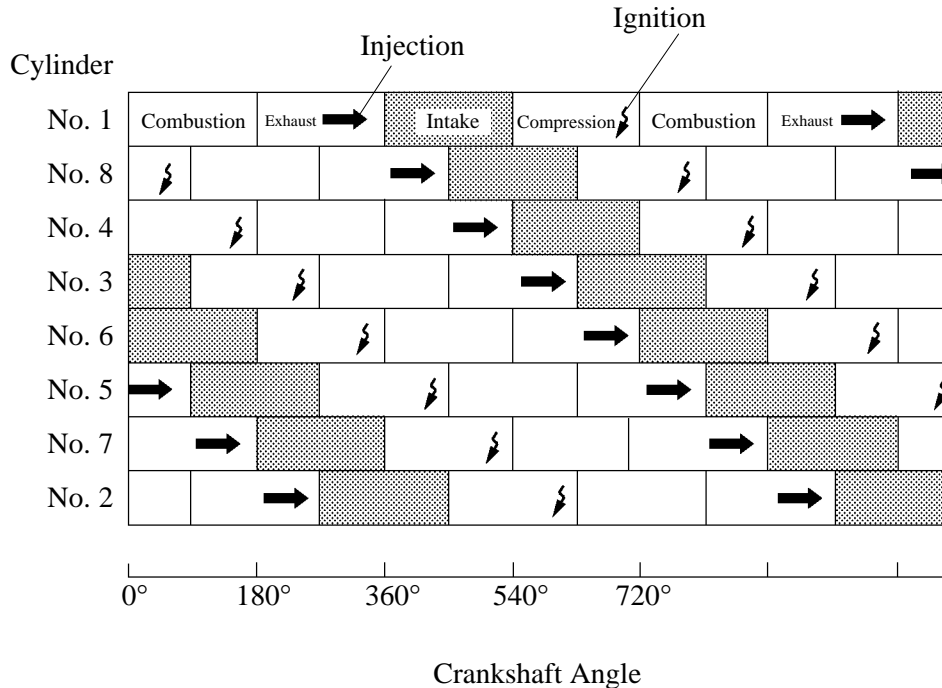

188EG20

44 VALVE MECHANISM

1. General

- Each cylinder has 2 intake valves and 2 exhaust valves. Intake and exhaust efficiency has been increased due to the larger total port areas.
- The valves are directly opened and closed by 4 camshafts.
- The intake camshafts are driven by a timing belt, while the exhaust camshafts are driven through gears on the intake camshafts.
- The VVT-i (Variable Valve Timing-intelligent) system is used to improve fuel economy, engine performance and reduce exhaust emissions. For details, see page 69.
- In contrast to the 1UZ-FE engine on the '00 LS400, an automatic timing belt tensioner with optimized construction and body material that has been changed to aluminum has been adopted in the 3UZ-FE engine on the '01 LS430.

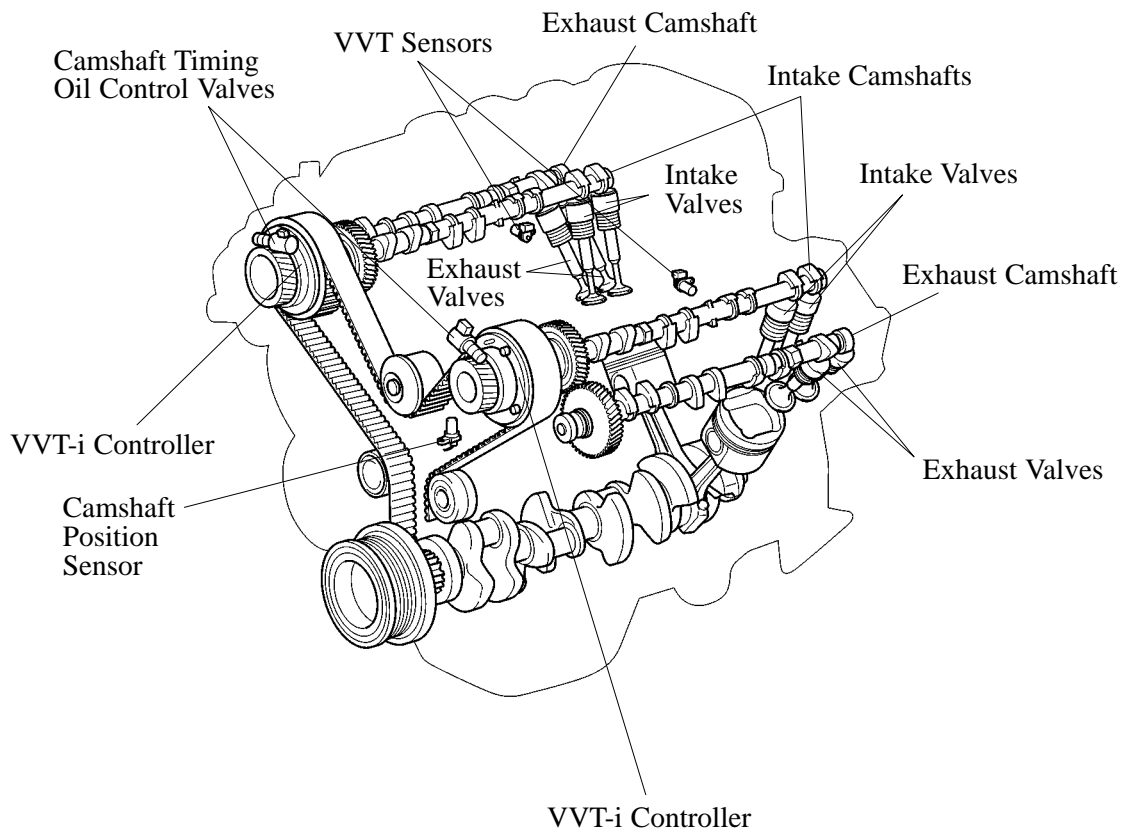

2. Camshaft

- The exhaust camshafts are driven by gears on the intake camshafts. The scissors gear mechanism has been used on the exhaust camshaft to control backlash and reduce gear noise.
- A VVT-i controllers have been installed on the front of the intake camshafts to vary the timing of the intake valves.
- In conjunction with the adoption of the VVT-i system, an oil passage is provided in the intake camshaft in order to supply engine oil to the VVT-i system.
- The intake camshaft is provided with timing rotor to trigger the VVT sensor.

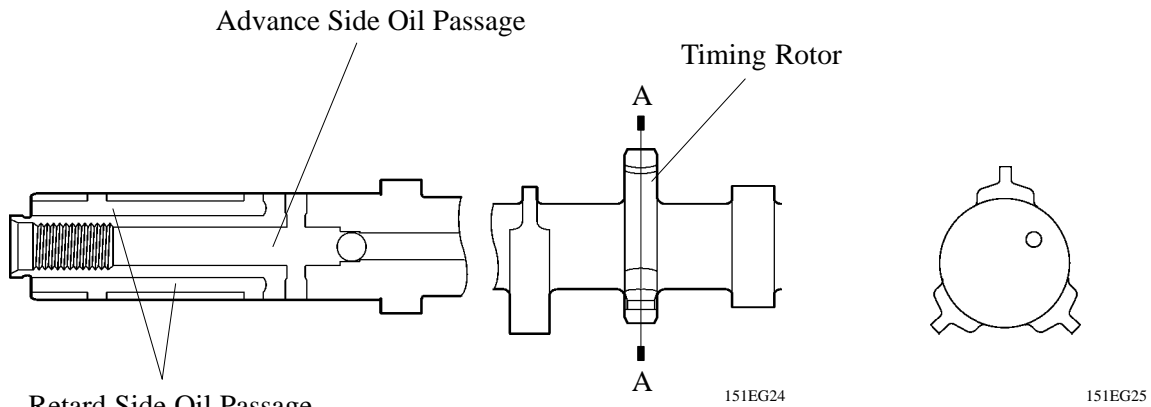

A – A Cross Section

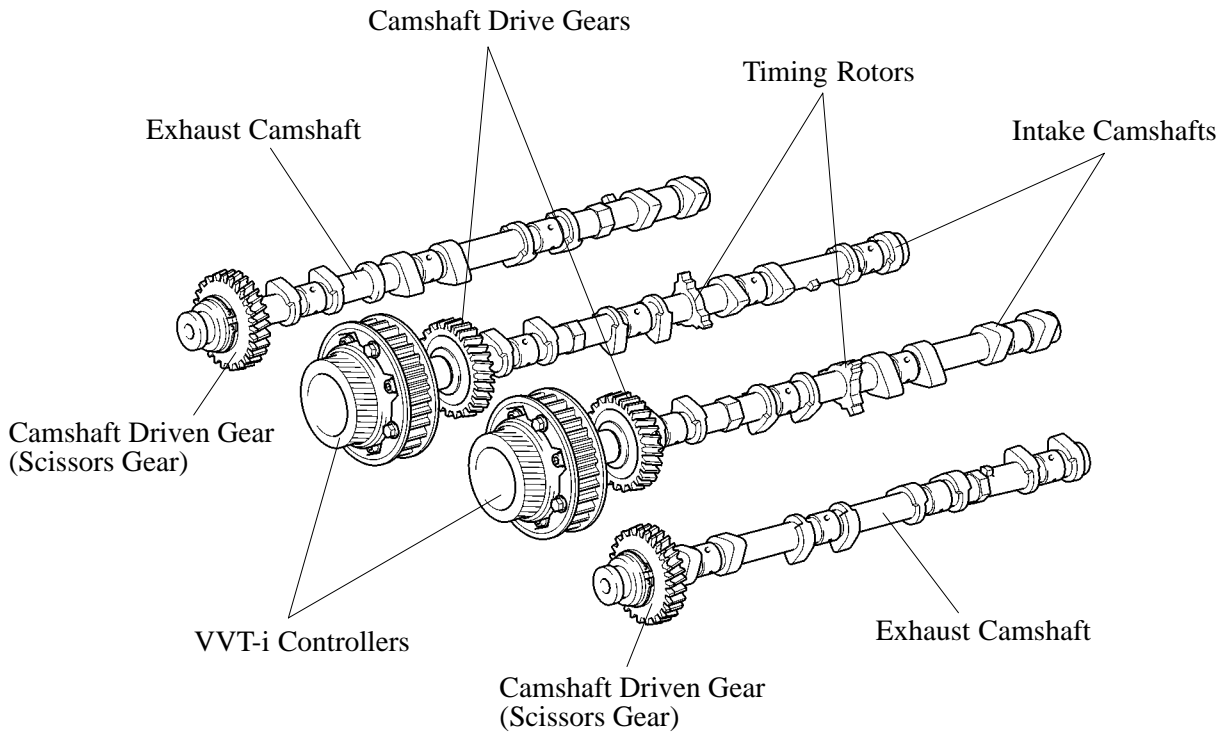

4.3. Intake and Exhaust Valve and Valve Lifter

- An inner shim type valve adjusting shim has been adopted as well as the 1UZ-FE engine on the '00 LS400.
- The valve lifter, which has been made lighter and thinner.
- High-strength, heat-resistant steel is used in both the intake and exhaust valves, and soft nitriding treatment has been applied to the stem and the face areas of the valves.
- Carbon steel with a round-shaped cross section has been adopted for the valve spring, which is used for both the intake and exhaust valves.

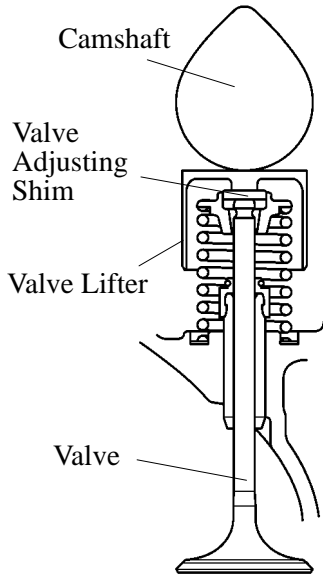

● Specifications ◀

Item	mm (in.)	
	Intake Valve	Exhaust Valve
Face Diameter	34.5 (1.36)	29.0 (1.14)
Stem Diameter	5.5 (0.22)	5.5 (0.22)

4. Timing Pulleys, Automatic Tensioner and Timing Belt Cover

- In contrast to the 1UZ-FE engine on the '00 LS400, an automatic timing belt tensioner with optimized construction and body material that has been changed to aluminum has been adopted in the 3UZ-FE engine on the '01 LS430.
- The timing belt cover No. 3 is made of aluminum to reduce noise.
- The timing belt cover No. 1 and No. 2 are composite formed with a gasket to improve serviceability.

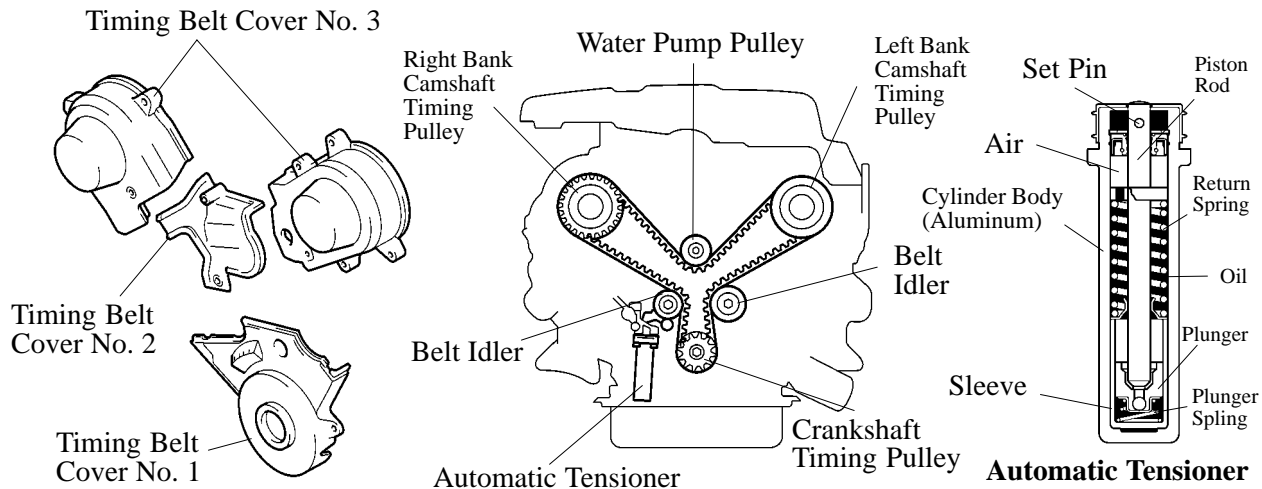

• **LUBRICATION SYSTEM**

- The lubrication circuit is fully pressurized and oil passes through an oil filter.
- The trochoid gear type oil pump is directly driven by the crankshaft.
- Along with the adoption of the VVT-i (Variable Valve Timing-intelligent), right bank and left bank cylinder heads are provided with VVT-i controllers and camshaft timing oil control valves. This system is operated by the engine oil.

Camshaft Timing
Oil Control Valves

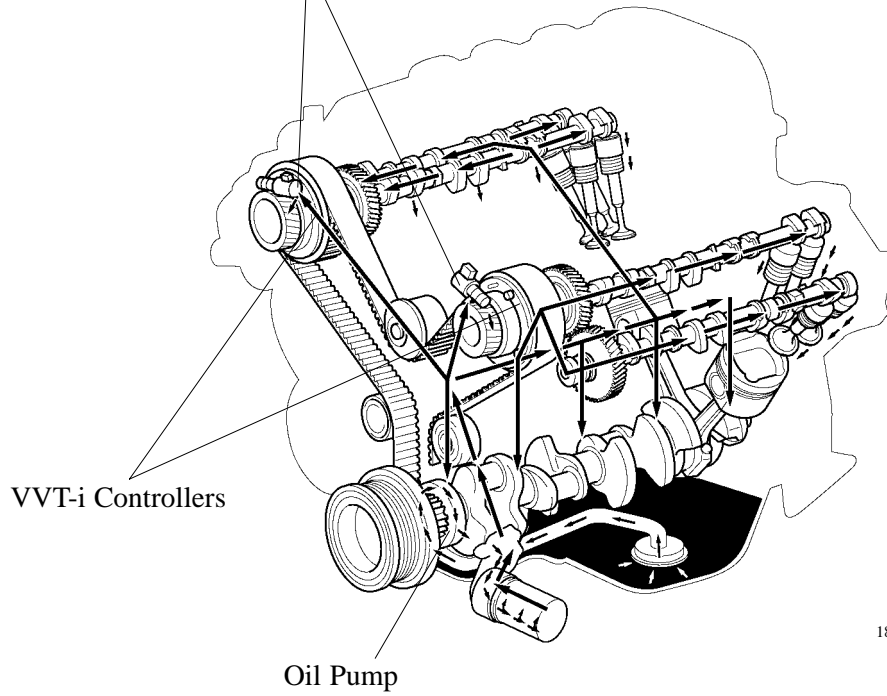

189EG42

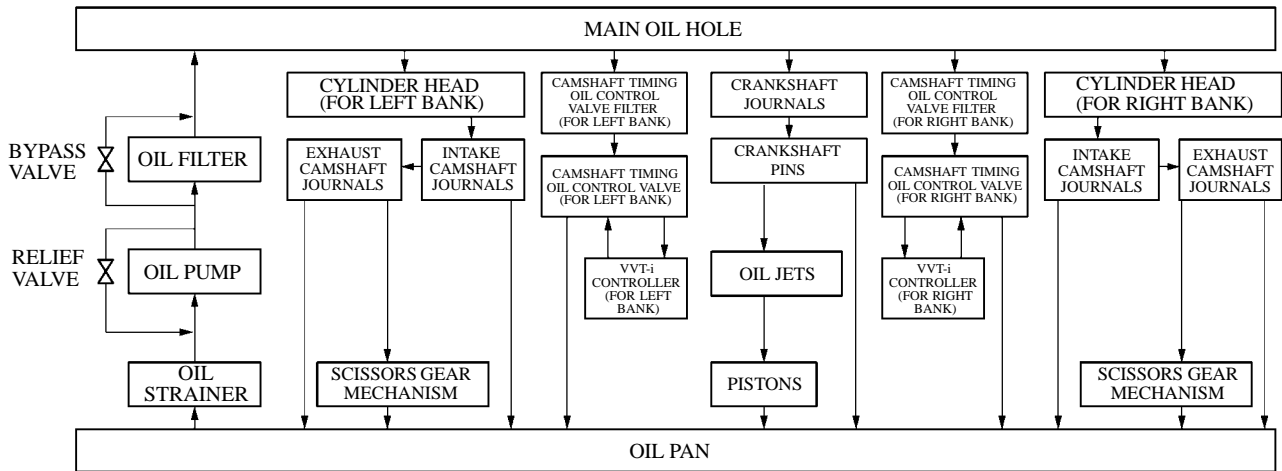

188EG27

1. General

- The cooling system is a pressurized, forced-circulation type.
- A thermostat, having a by-pass valve, is located on the water pump inlet side of the cooling circuit. As the coolant temperature rises, the thermostat opens and the by-pass valve closes, so the system maintains suitable temperature distribution in the cylinder head.
- In contrast to the 1UZ-FE engine on the '00 LS400, the shape of the water inlet housing has been optimized in the 3UZ-FE engine on the '01 LS430 to achieve the smooth flow of the engine coolant.
- In contrast to the 1UZ-FE engine on the '00 LS400, in which a fluid coupling type cooling fan was used, the 3UZ-FE engine on the '01 LS430 has adopted an electric cooling fan system.
- The ECM is installed in the ECM box in the engine compartment. As a result, the wiring harness has been shortened, thus realizing weight reduction.

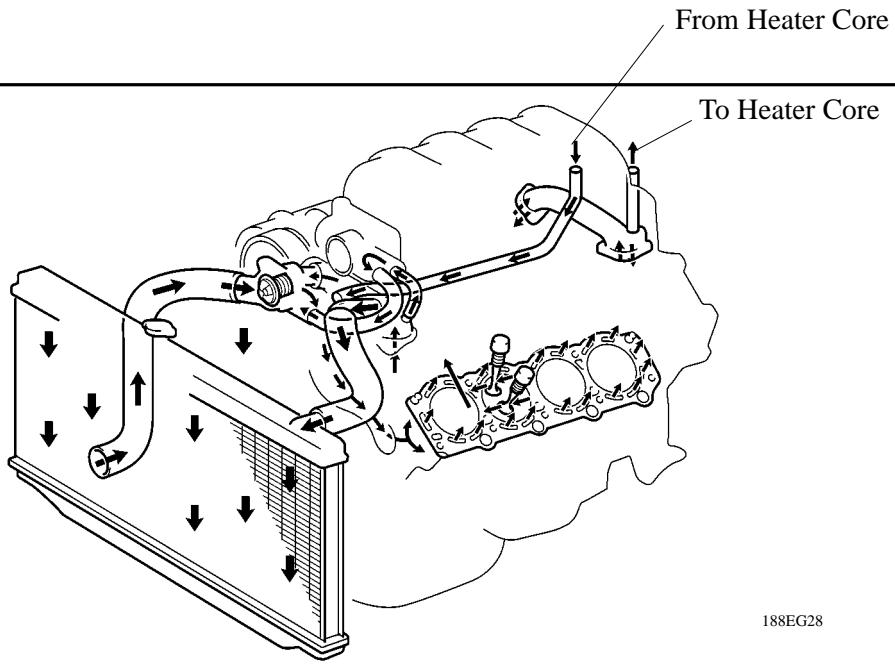

188EG28

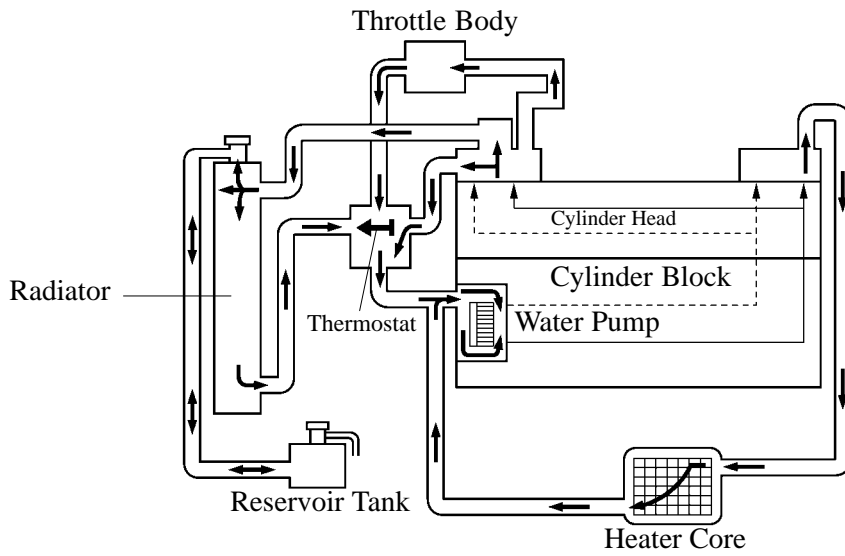

189EG01

2. Water Pump

- The water pump has two volute chambers, and circulates coolant uniformly to the left and right banks of the cylinder block.
- The water pump is driven by the back of the timing belt.
- The rotor is made of resin.

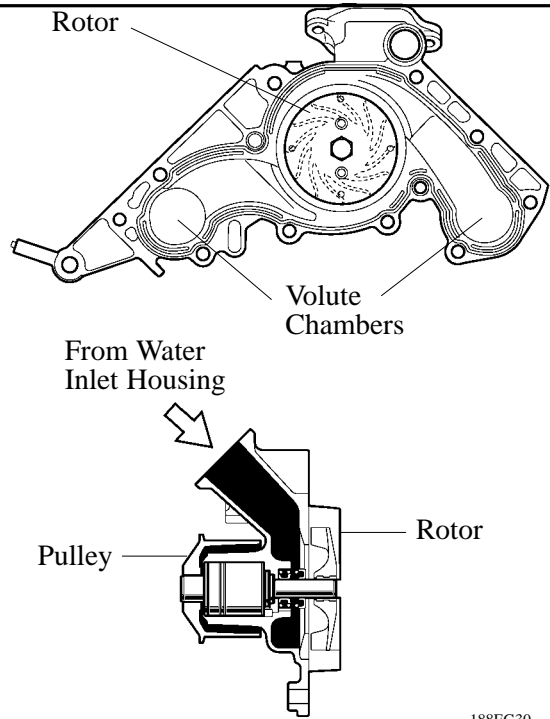

3. Water Inlet Housing

In contrast to the 1UZ-FE engine on the '00 LS400, the shape of the water inlet housing has been optimized in the 3UZ-FE engine on the '01 LS430 to achieve the smooth flow of the engine coolant.

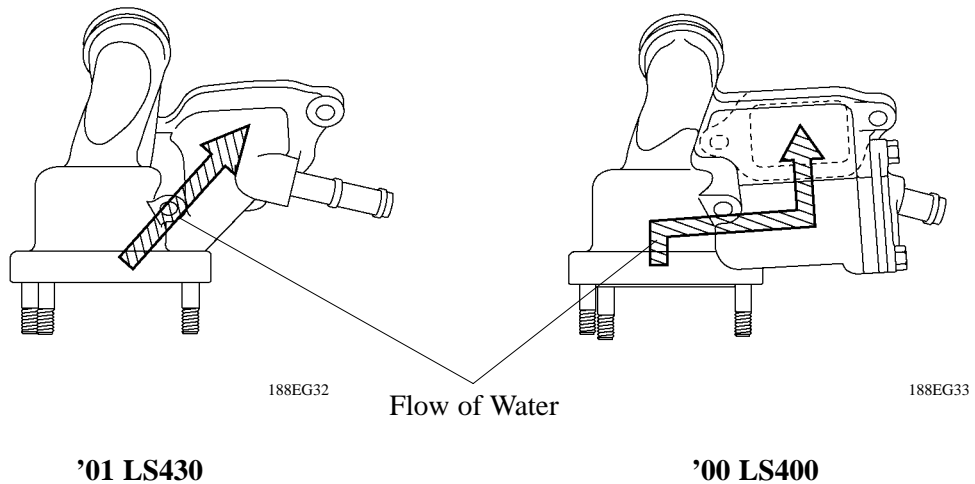

5.4. Cooling Fan System

- This system consists of 2 fans with a different number of blades. The main fan contains 5 blades and the sub fan contains 7 blades. These fans are actuated by the cooling fan ECU in accordance with the signals from the ECM.

A simplified sealing type reservoir tank has been provided for the fan shroud.

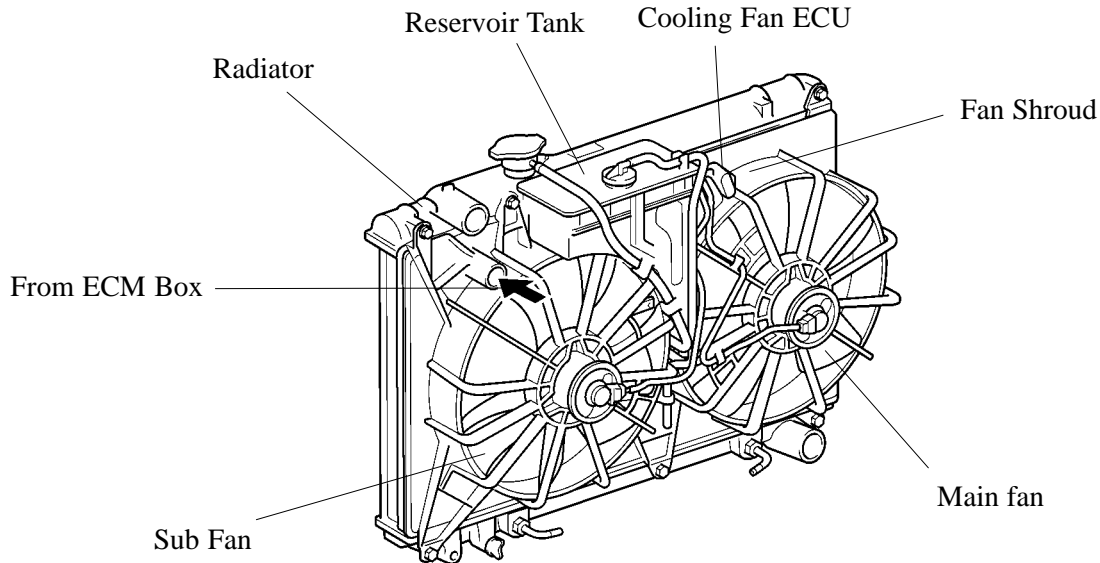

189EG02

- The ECM is installed in the ECM box in the engine compartment. As a result, the wiring harness has been shortened, thus realizing weight reduction.

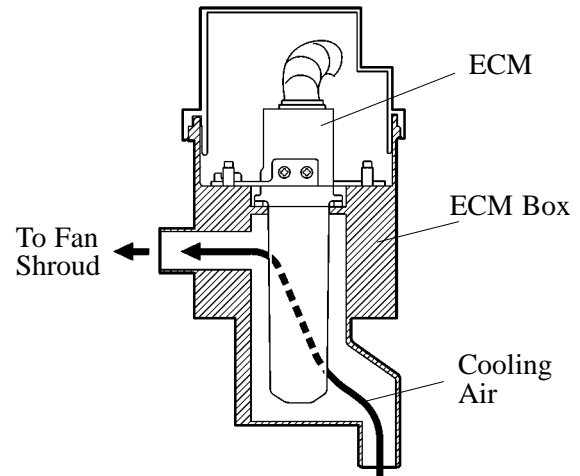

189EG03

1. Air Cleaner

- A resonator and a tuning hole have been provided in the air cleaner inlet to reduce the amount of intake air sound.
- The air cleaner case has been increased in size to reduce the amount of intake air sound, and the construction of the air cleaner element has been optimized to achieve weight reduction.

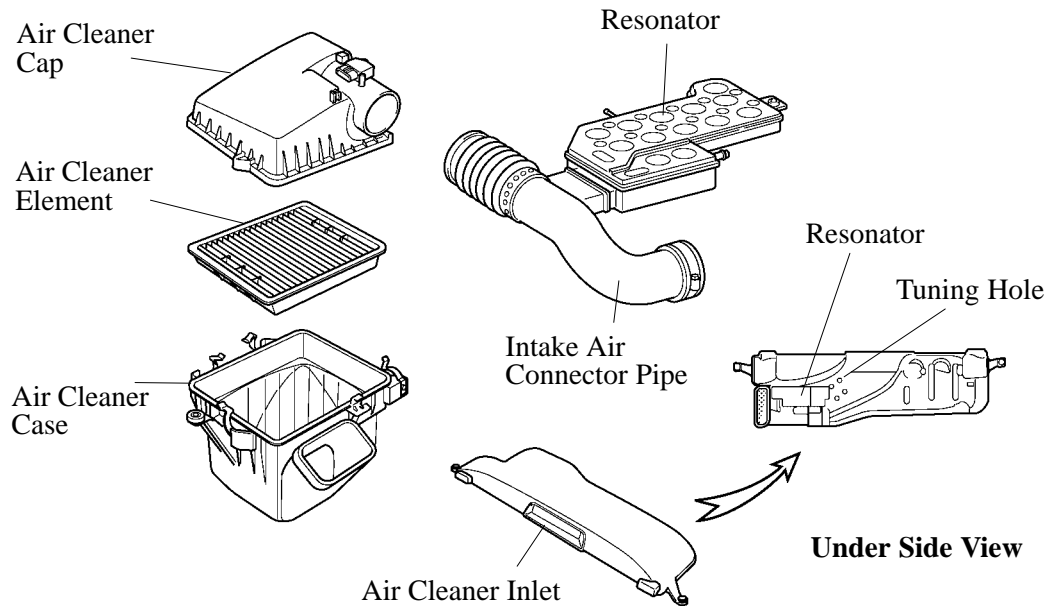

189EG04

2. Intake Manifold

- The low-to mid-speed range torque has been improved by increasing the length of the intake manifold port.
- The air intake chamber consists of upper and lower sections and contains an intake air control valve. This valve is activated by ACIS (Acoustic Control Induction System) and is used to alter the intake pipe length to improve the engine performance in all speed ranges. For details, see page 80.

Front

Intake Air Control Valve

Actuator
(for ACIS)

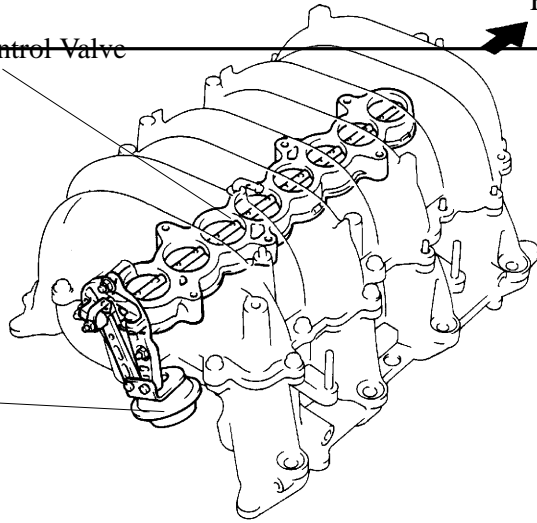

3. Intake Manifold Gasket

- A heat-barrier gasket has been adopted for use between the cylinder head and the intake manifold. This gasket, which restrains the heat transfer from the cylinder head to the intake manifold, helps restrain the intake air temperature and improve the charging efficiency.
- The construction of the gasket consists of resin that is sandwiched between metal gaskets.

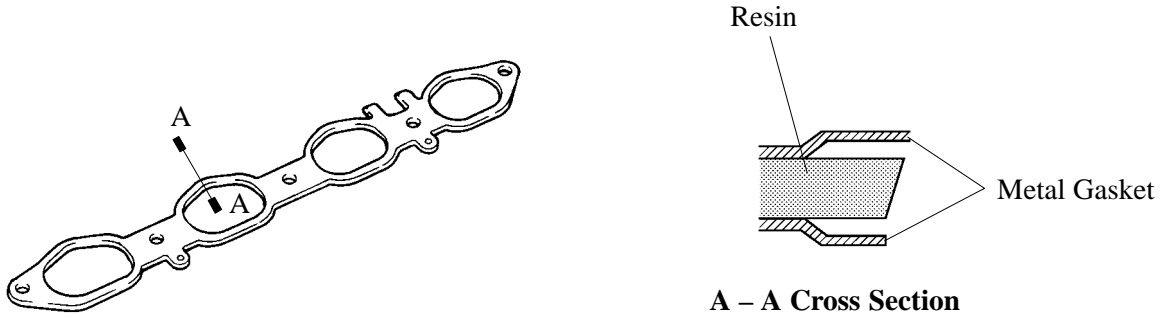

151EG69

144EG04

4. Exhaust Manifold

- The front exhaust pipe has been shortened and the warm-up performance of the TWC (Three-Way Catalytic Converter) has been improved.
- Cooling holes have been provided in the heat insulator for cooling the exhaust manifold.

● **Right-Hand Exhaust Manifold** ◀

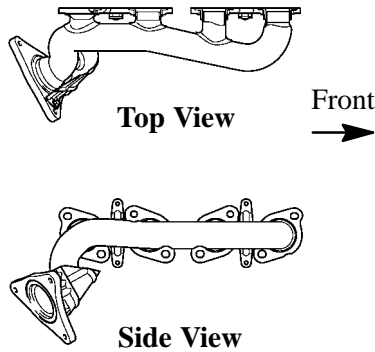

188EG36

● **Left-Hand Exhaust Manifold** ◀

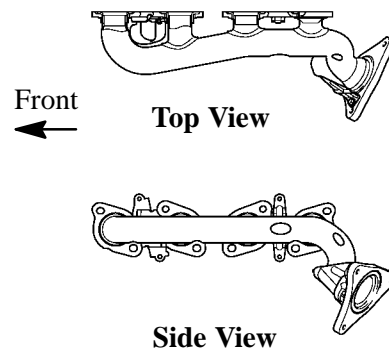

188EG37

● **Right-Hand Heat Insulator** ◀

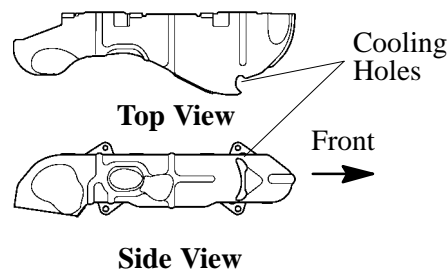

188EG38

● **Left-Hand Heat Insulator** ◀

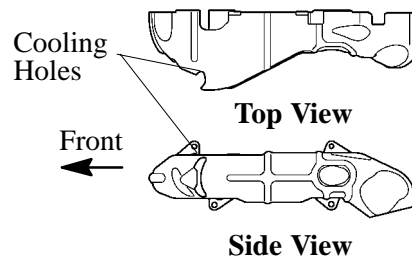

188EG39

5. Exhaust Pipe

Two TWCs (Three-way Catalytic Converters) have been provided in the front, and one in the center.

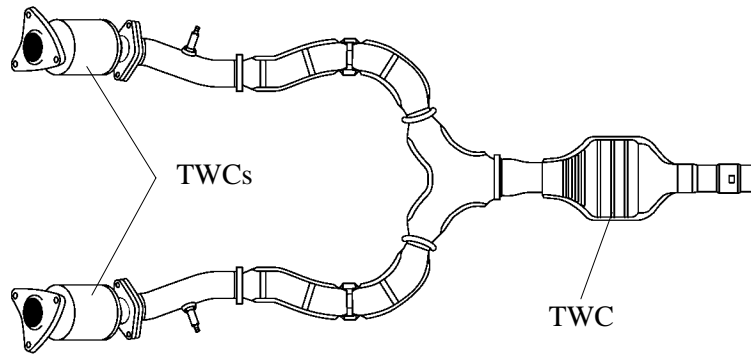

189EG39

6. Three Way Catalytic Converter

An ultra thin-wall, high-cell ceramic type TWC has been adopted. This TWC enables to optimize the cells density and to reduce wall thickness.

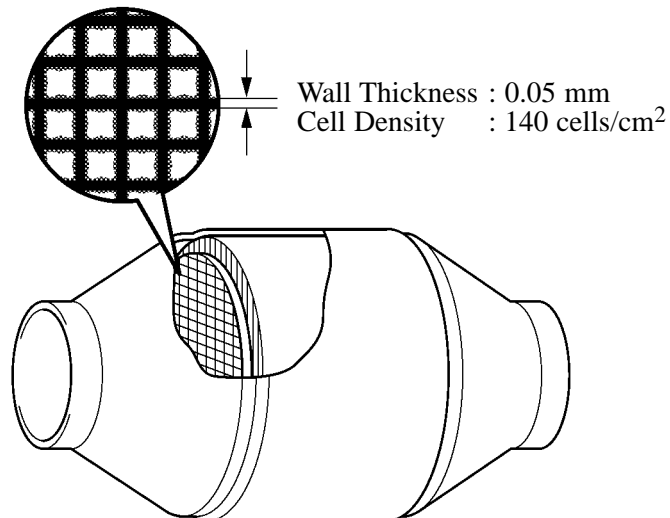

189EG21

1. General

- A saddle-shaped fuel tank has been adopted.
- A compact fuel pump in which a fuel filter, pressure regulator and jet pump are integrated in the module fuel pump assembly has been adopted.
- The charcoal canister, which was provided in the luggage compartment of the '00 LS400, has been relocated outside, underneath the luggage compartment on the '01 LS430.
- A fuel returnless system has been used to reduce evaporative emissions.
- An air-assist system has been adopted to improve the atomization of fuel, thus improving the performance of the evaporative emissions.
- A compact 4-hole type fuel injector has been used.
- The ORVR (On-Board Refueling Vapor Recovery) system has been used.

2. Fuel Returnless System

- The fuel returnless system has been used to reduce evaporative emissions. With the pressure regulator and the fuel filter-integrated fuel pump are housed inside the fuel tank, this system eliminates the return of fuel from the engine area. This helps prevent the internal temperature of the fuel tank from rising, and reduces evaporative emissions.
- 2 pulsation dampers are used to realize a quieter operation.

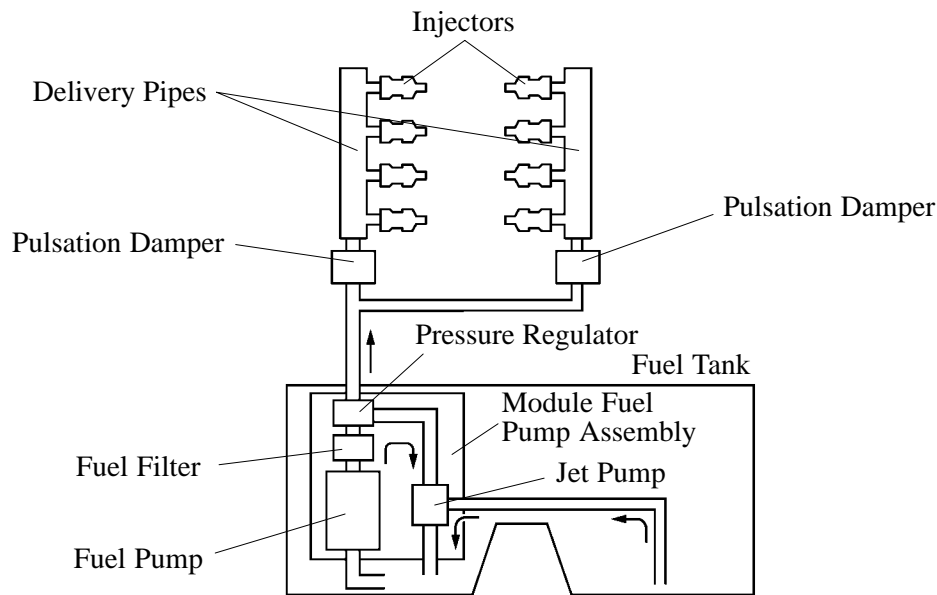

58. Air-Assist System

This system is designed to regulate air intake (atmospheric side) using the throttle valve, and direct it to the nozzle of the fuel injector inside the intake manifold (negative pressure side). This promotes atomization of the fuel while reducing emissions and improving fuel economy and idle stability.

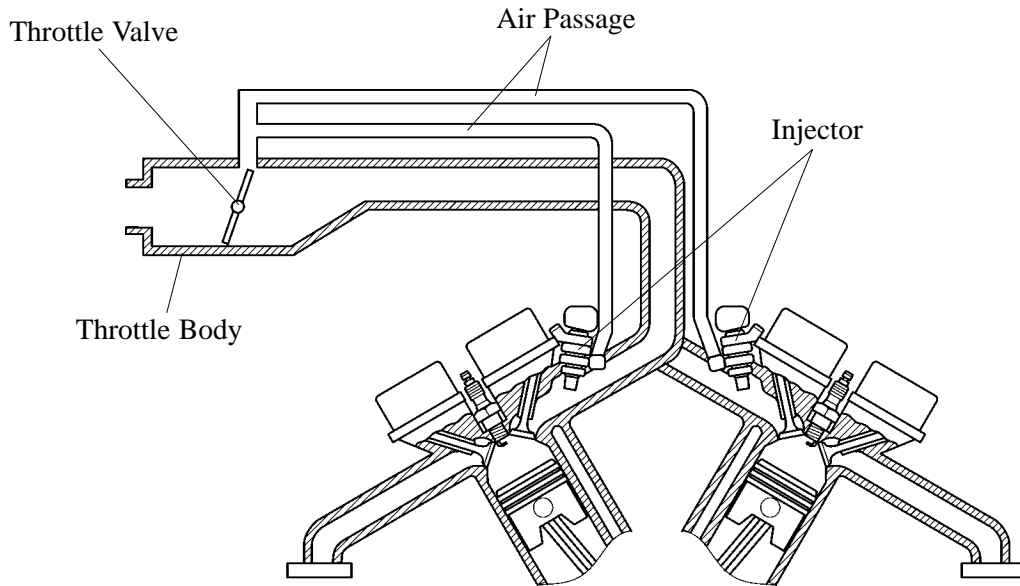

151EG35

4. Fuel Injector

- A compact 4-hole type fuel injector has been used.
- Air introduced from the throttle body and air gallery flows through the air chamber formed by the O-ring and insulator under the fuel injector and then is mixed with the fuel. This design promotes atomization of the fuel.

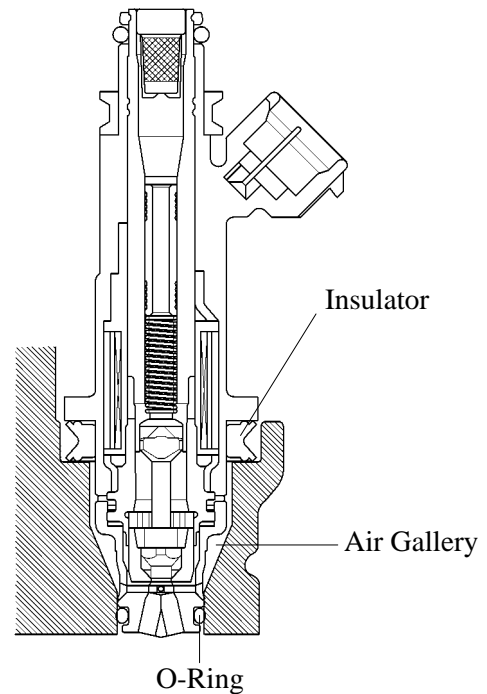

151EG36

5. Fuel Tank

- The fuel tank adopts a saddle shape to allow the propeller shaft to pass through its center portion. Also, a jet pump is provided to transfer the fuel from the side of the tank without the fuel pump to the side with the fuel pump.
- Two sender gauges, the main and sub sender gauges, are provided to improve the accuracy of the fuel gauge.

Jet Pump

A jet pump is adopted in the fuel tank. Since the propeller shaft is located below its center bottom, the fuel tank of the new LS430 is shaped as indicated below.

A fuel tank with such a shape tends to cause the fuel to be dispersed into both chamber A and chamber B when the fuel level is low, stopping the fuel in chamber B from being pumped out. To prevent this from occurring, a jet pump has been provided to transfer the fuel from chamber B to chamber A.

This is accomplished by utilizing the flow of the fuel, so that the vacuum created by the fuel, as it passes through the venturi is used to suck the fuel out of chamber B and send it to chamber A.

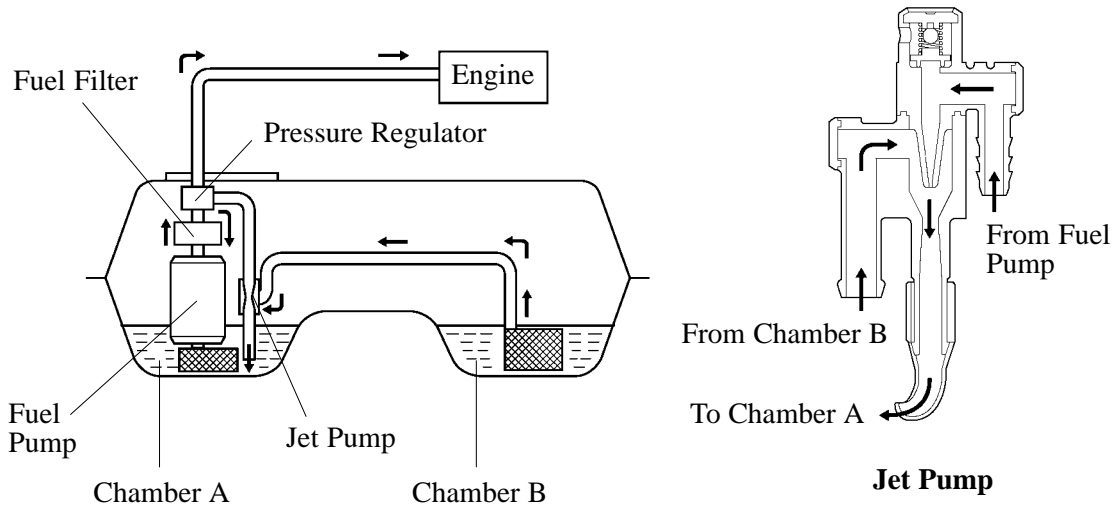

152EG06

152EG07

Fuel Sender Gauge

Two sender gauges, the main and sub, are provided to improve the accuracy of the fuel gauge. These sender gauges, which are provided inline in chambers A and B, send the signals representing the residual volume of fuel in both chambers via the luggage room junction block ECU to the meter ECU. Based on the signals from the 2 sender gauges and the fuel injection volume data from the ECM, the meter ECU calculates the residual volume of fuel and actuates the fuel gauge in the combination meter.

● System Diagram ◀

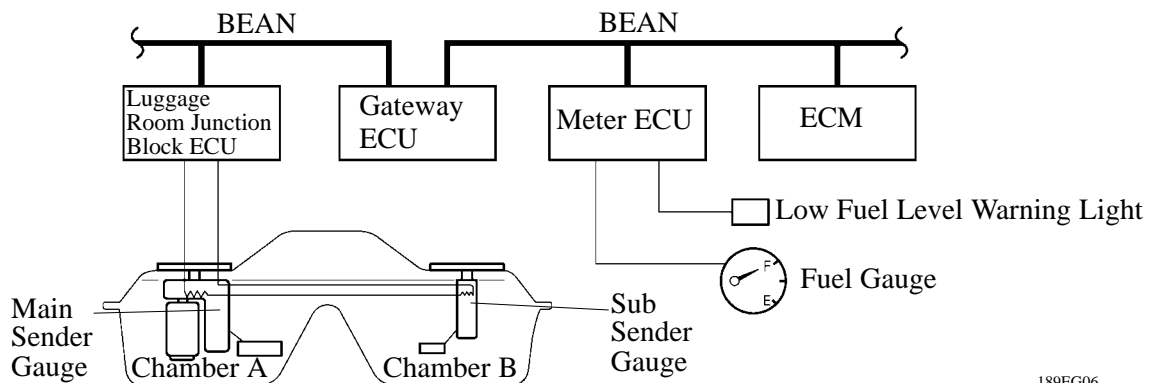

189EG06

6. Module Fuel Pump Assembly

The main sender gauge, fuel pump, fuel filter, pressure regulator and jet pump have been integrated.

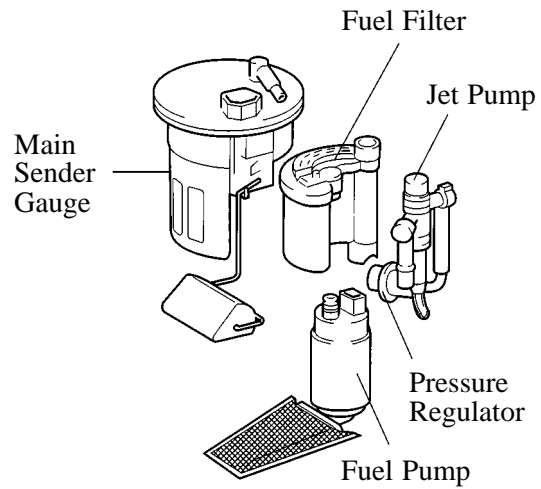

163EG35

7. ORVR System

General

The ORVR (On-Board Refueling Vapor Recovery) is a system that uses a charcoal canister, which is provided onboard, to recover the fuel vapor that is generated during refueling. This reduces the discharge of fuel vapor into the atmosphere.

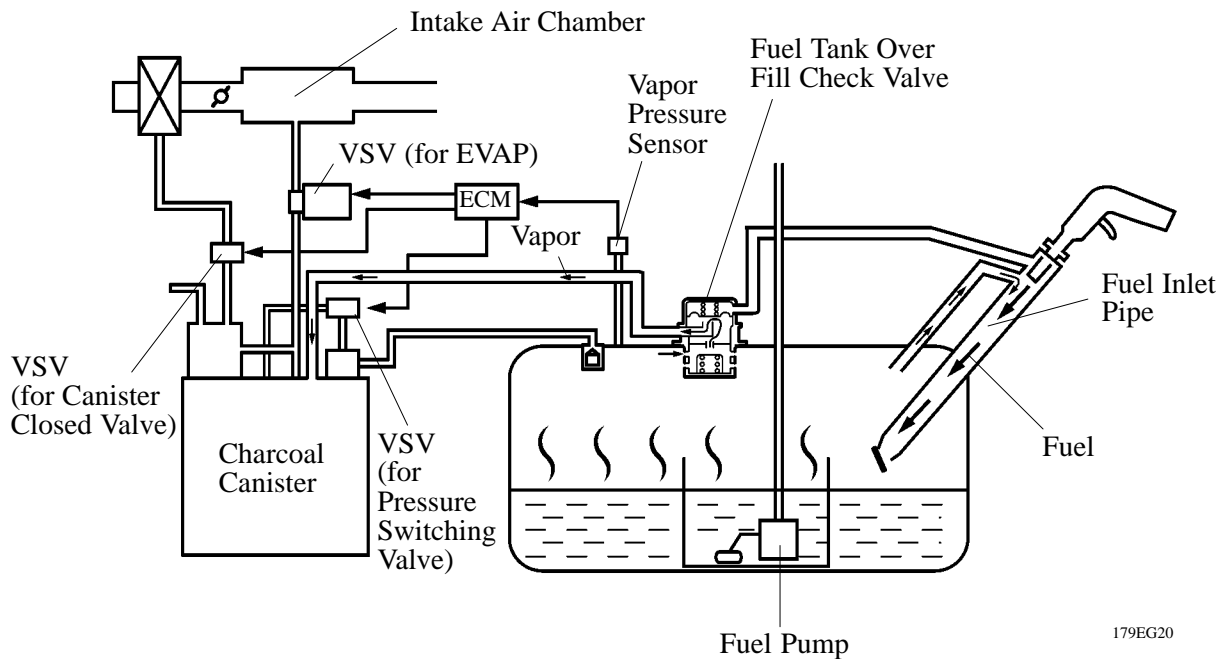

179EG20

When the fuel tank cap is removed, atmosphere applies to the fuel tank over fill check valve's chamber A. Refueling causes the internal pressure of the fuel tank to increase, the vapor flows to the charcoal canister while maintaining valve B pressed, thus allowing the vapor to become absorbed by the charcoal canister. When the tank is full, valve C closes, thus shutting off the passage to the charcoal canister.

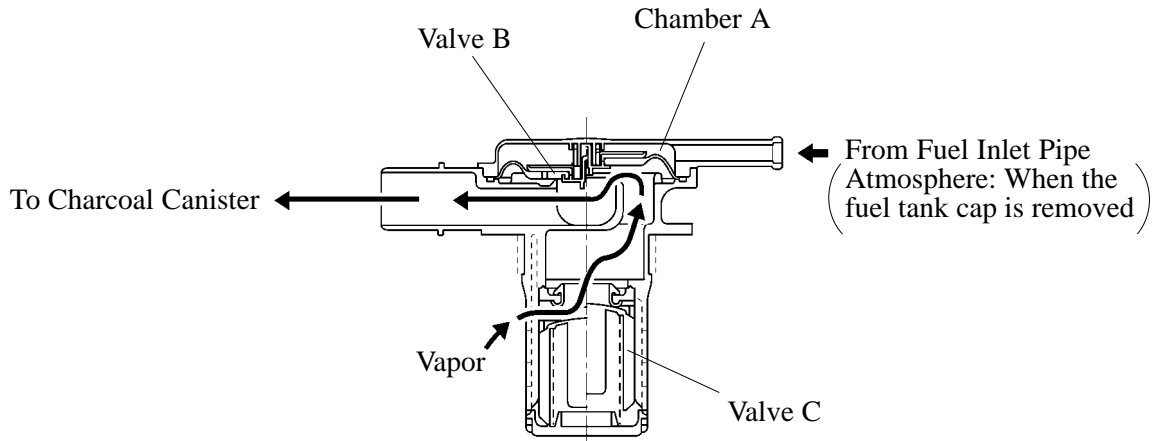

Fuel Tank Over Fill Check Valve

62IGNITION SYSTEM

1. General

- A DIS (Direct Ignition System) has been adopted. The DIS improves the ignition timing accuracy, reduces high-voltage loss, and enhances the overall reliability of the ignition system by eliminating the distributor. The DIS in this engine is an independent ignition system which has one ignition coil (with igniter) for each cylinder.
- Iridium-tipped spark plugs have been adopted.
- In contrast to the 1UZ-FE engine on the '00 LS400, compact and lightweight ignition coils with an optimized construction have been adopted in the 3UZ-FE engine on the '01 LS430.

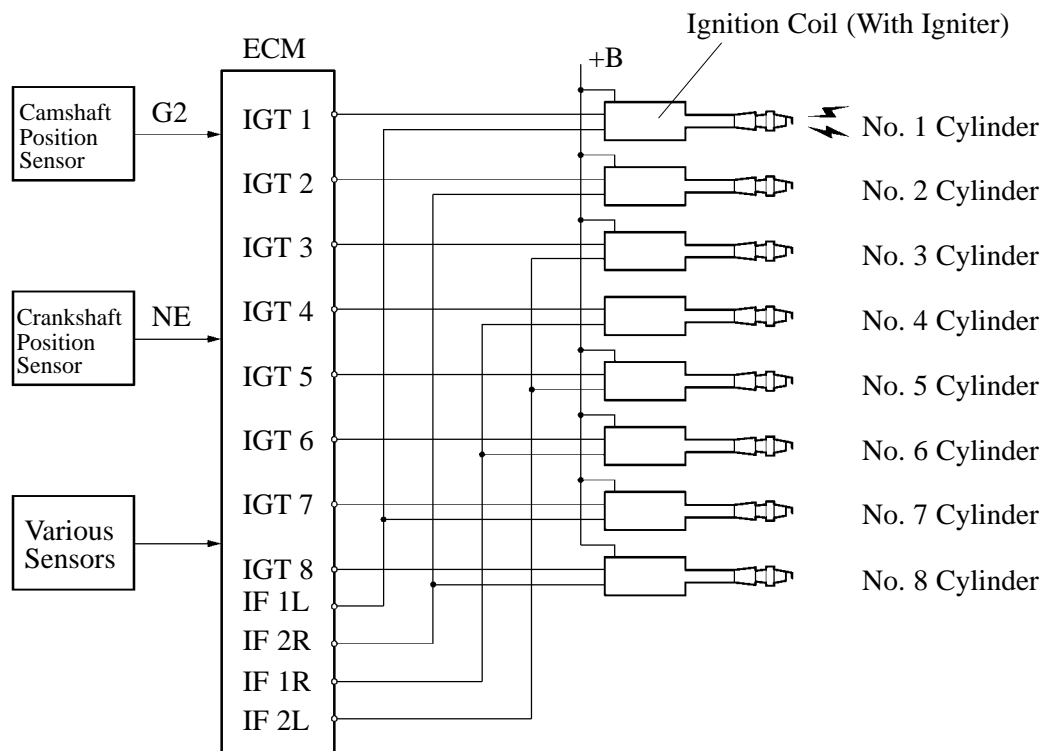

2. Spark Plug

Iridium-tipped spark plugs have been adopted to realize a 120,000-mile (192,000 km) maintenance-free operation. Their center electrode is made of iridium, which excels in wear resistance. As a result, the center electrode is made with a smaller diameter and improved the ignition performance.

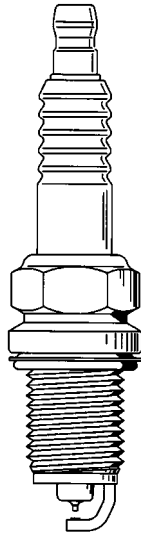

● Recommended Spark Plugs ◀

DENSO	SK20R11
NGK	IFR6A11
Plug Gap	1.0 – 1.1 mm (0.0394 – 0.043 in.)

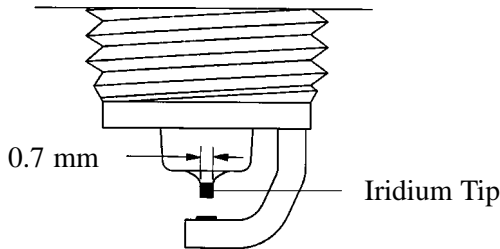

151EG39

3. Ignition Coil (with Igniter)

The DIS provides 8 ignition coils, one for each cylinder. The spark plug caps, which provide contact to the spark plugs, are integrated with an ignition coil. Also, an igniter is enclosed to simplify the system. However, in contrast to the 1UZ-FE engine on the '00 LS400, compact and lightweight ignition coils with an optimized construction have been adopted in the 3UZ-FE engine on the '01 LS430.

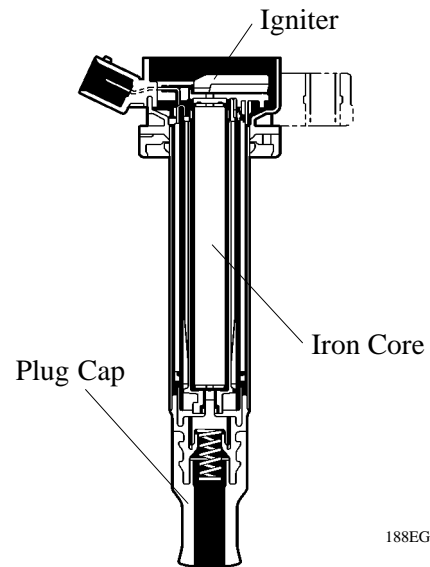

188EG41

Ignition Coil Cross Section

64 SERPENTINE BELT DRIVE SYSTEM

1. General

- Accessory components are driven by a serpentine belt consisting of a single V-ribbed belt. It reduces the overall engine length, weight and number of engine parts.
- An automatic tensioner eliminates the need for tension adjustment.

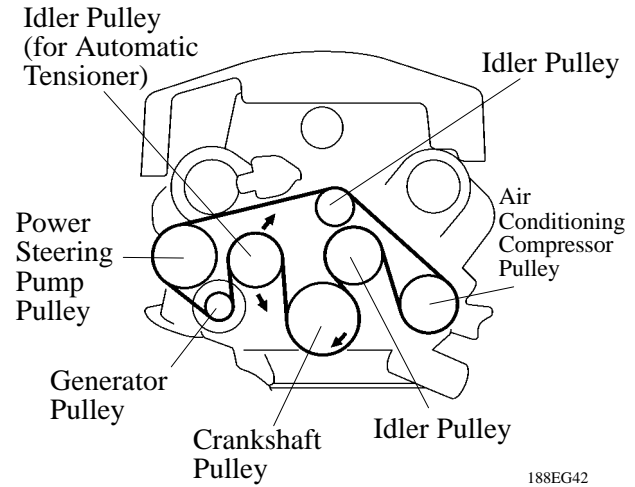

188EG42

2. Automatic Tensioner

The automatic tensioner, which mainly consists of an idler pulley, an arm, a spring case, and a torsion spring, maintains the tension of the V-ribbed belt constant through the force of the torsion spring.

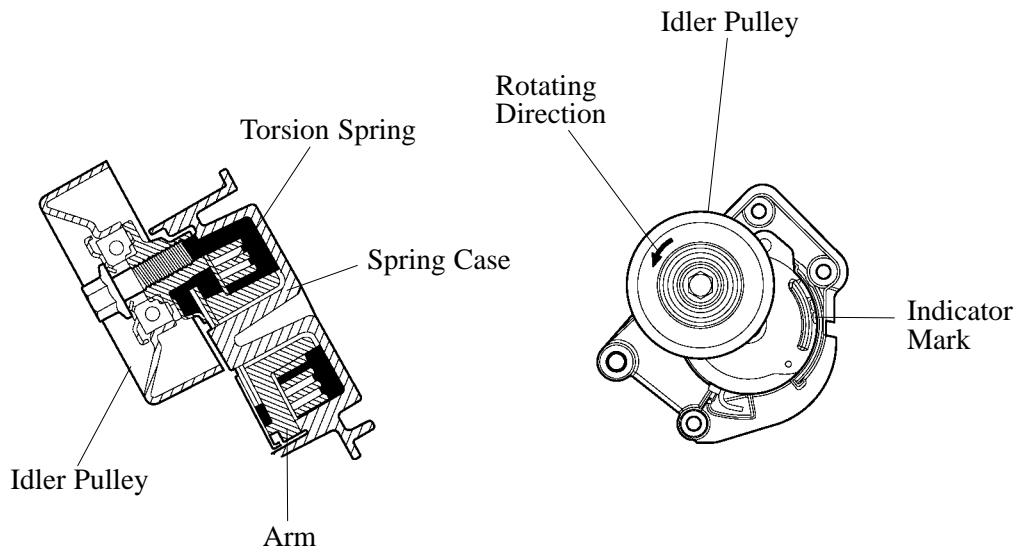

188EG43

• ENGINE CONTROL SYSTEM

1. General

The engine control system of the 3UZ-FE engine on the '01 LS430 is basically same in construction and operation as that of the 1UZ-FE engine for the '00 LS400.

The engine control system of the 3UZ-FE engine in the '01 LS430 and 1UZ-FE engine in the '00 LS400 are compared below.

System	Outline	3UZ-FE	1UZ-FE
SFI (Sequential Multiport Fuel Injection)	An L-type SFI system directly detects the intake air mass with a hot wire type air flow meter.	○	○
ESA (Electronic Spark Advance)	Ignition timing is determined by the ECM based on signals from various sensors. The ECM corrects ignition timing in response to engine knocking.	○	○
	2 knock sensors are used to improve knock detection.	○	○
	The torque control correction during gear shifting has been used to minimize the shift shock.	○	○
VVT-i (Variable Valve Timing-intelligent)	Controls the intake camshaft to an optimal valve timing in accordance with the engine condition. For details, see page 69.	○	○
ETCS-i (Electronic Throttle Control System-intelligent)	Optimally controls the throttle valve opening in accordance with the amount of accelerator pedal effort and the condition of the engine and the vehicle. In addition, comprehensively controls the ISC, snow mode control, cruise control, VSC system and TRAC systems. For details, see page 74.	○	○
	Controls the throttle valve opening to effect adaptive laser cruise control.*	○	—
	Torque activated power train control has been adopted. Also, the fail-safe control has been reconsidered with the adoption of the link-less type throttle body. For details, see page 74.	○	—
ACIS (Acoustic Control Induction System)	The intake air passages are switched according to the engine speed and throttle valve angle to increase performance in all speed ranges. For details, see page 80.	○	○
Fuel Pump Control	The fuel pump speed is controlled by the fuel pump relay and the fuel pump resistor.	○	○
	The operation of the fuel pump will stop when the airbag is deployed at the front or side collision. For details, see page 84.	○	—
Oxygen Sensor Heater Control	Maintains the temperature of the oxygen sensor at an appropriate level to increase accuracy of detection of the oxygen concentration in the exhaust gas.	○	○
Cooling Fan Control	An electric cooling fan system has been adopted. The ECM steplessly controls the speed of the fans in accordance with the engine coolant temperature, vehicle speed, engine speed, and air conditioning operating conditions. As a result, the cooling performance has been improved.	○	—

*: with Adaptive Laser Cruise Control

System	Outline	3UZ-FE	1UZ-FE
Air Conditioning Cut-Off Control	By controlling the air conditioning compressor ON or OFF in accordance with the engine condition, drivability is maintained.	○	○
Evaporative Emission Control	The ECM controls the purge flow of evaporative emissions (HC) in the charcoal canister in accordance with engine conditions.	○	○
	Using 3 VSVs and a vapor pressure sensor, the ECM detects any evaporative emission leakage occurring between the fuel tank and the charcoal canister through the changes in the tank pressure. For details, see page 85.	○	○
Engine Immobiliser	Prohibits fuel delivery and ignition if an attempt is made to start the engine with an invalid ignition key.	○	○
Function to communicate with multiplex communication system	Communicates with the meter ECU, A/C ECU, etc., on the body side, to input/output necessary signals.	○	○
Diagnosis	When the ECM detects a malfunction, the ECM diagnoses and memorizes the failed section.	○	○
	The diagnosis system includes a function that detects a malfunction in the thermostat.	○	—
Fail-Safe	When the ECM detects a malfunction, the ECM stops or controls the engine according to the data already stored in the memory.	○	○

2. Construction

The configuration of the engine control system in the 3UZ-FE engine of the '01 LS430 is as shown in the following chart.

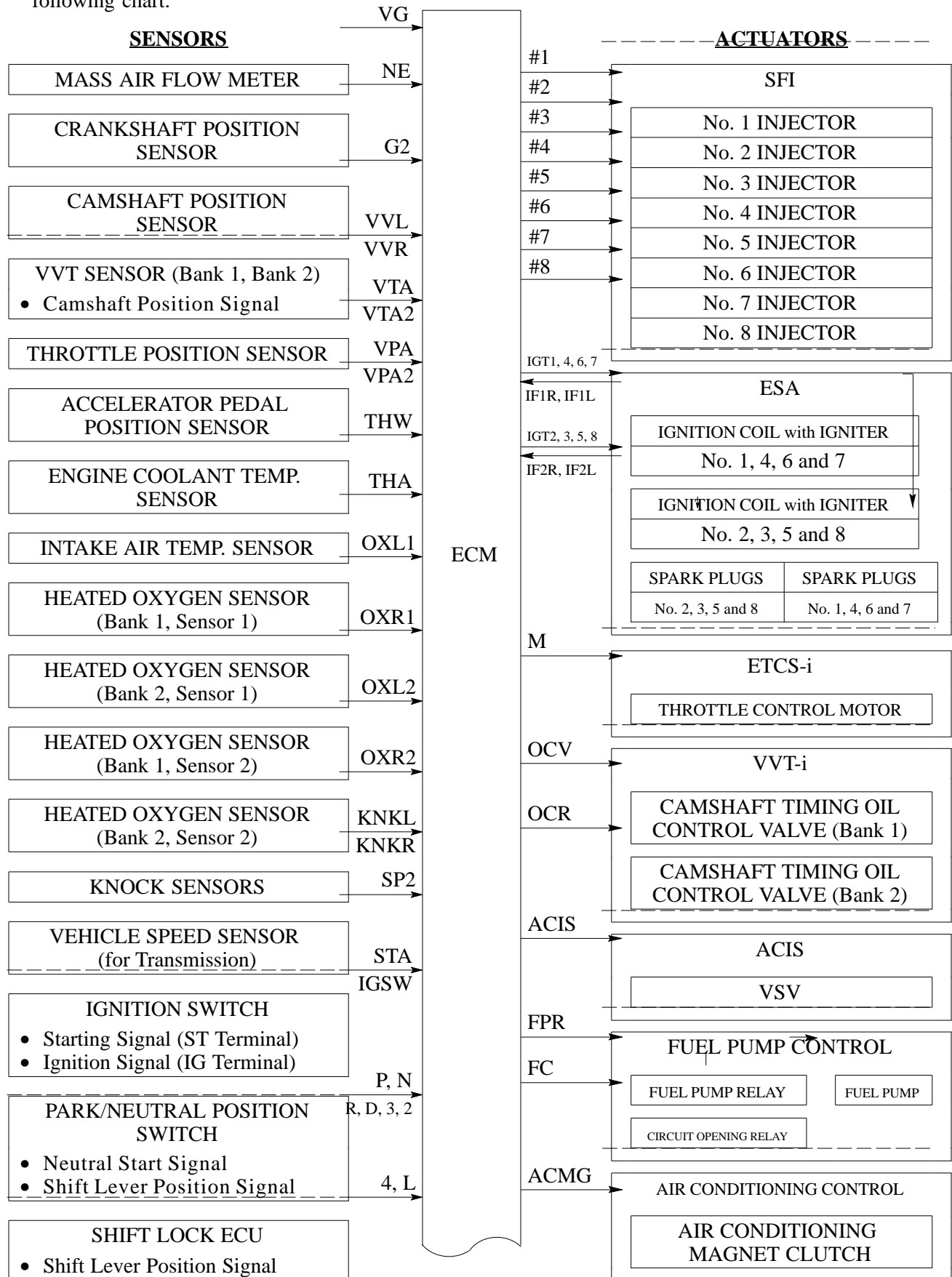

(Continued)

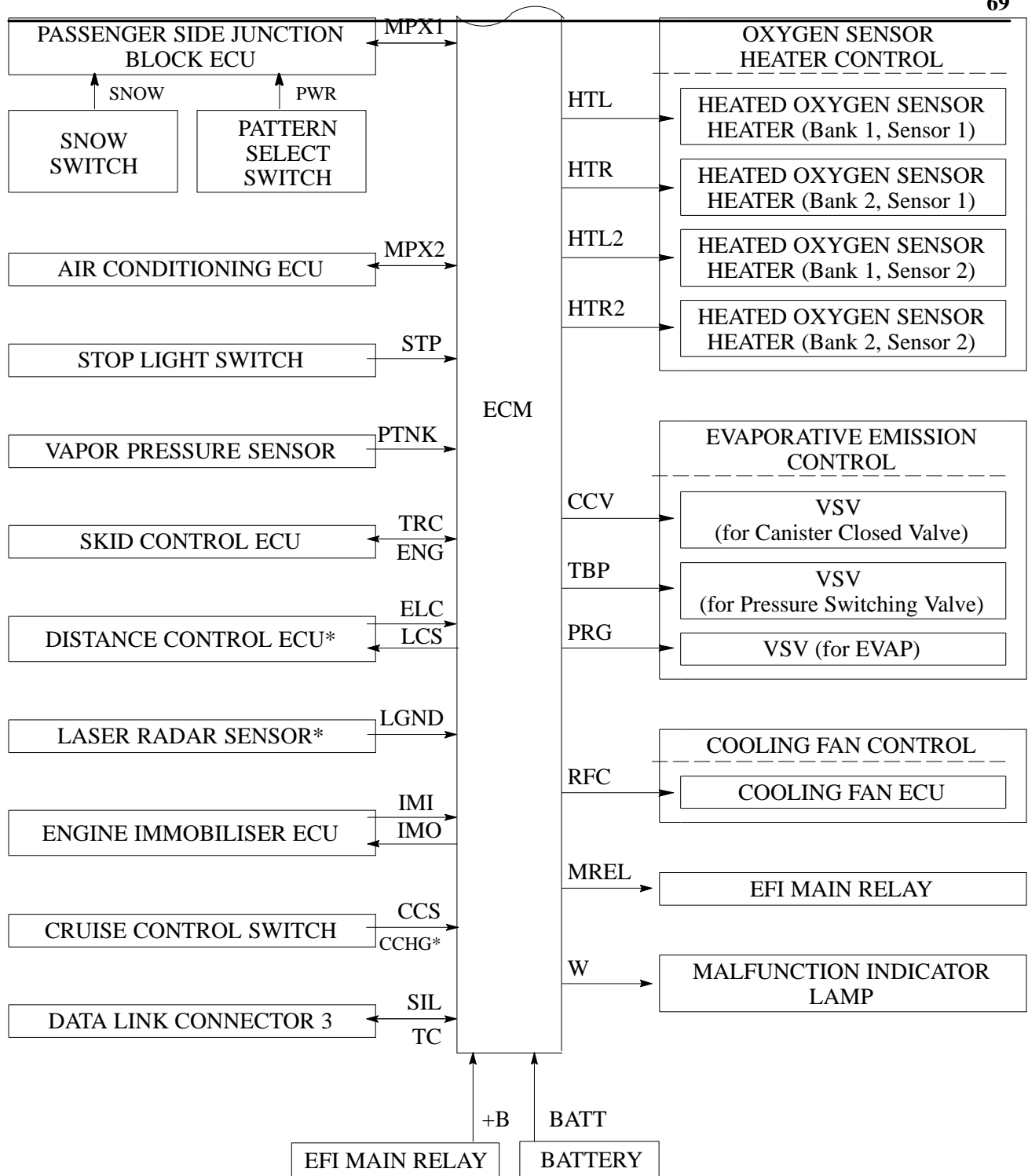

*: with Adaptive Laser Cruise Control

7B. Engine Control System Diagram

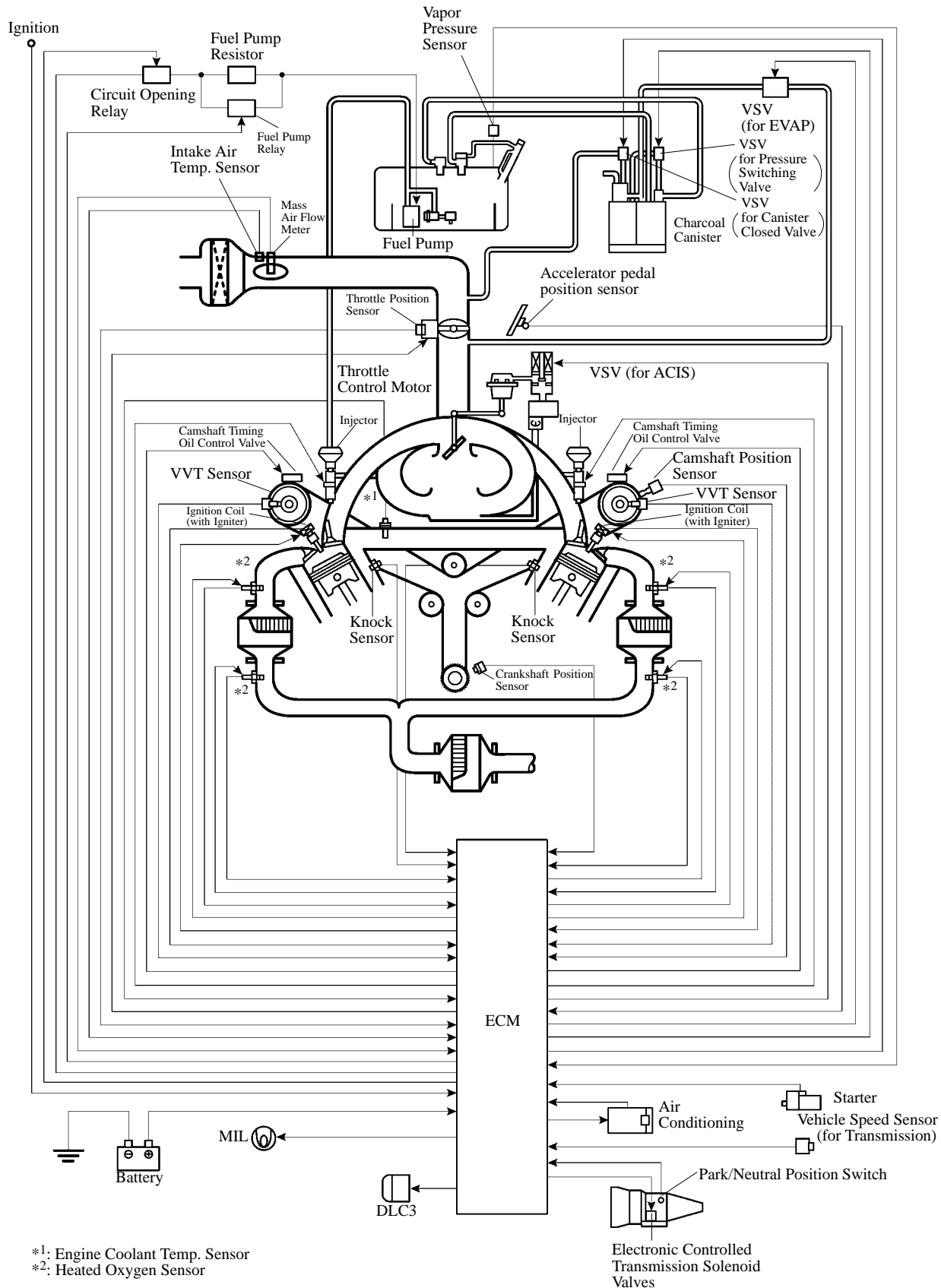

4. Layout of Main Components

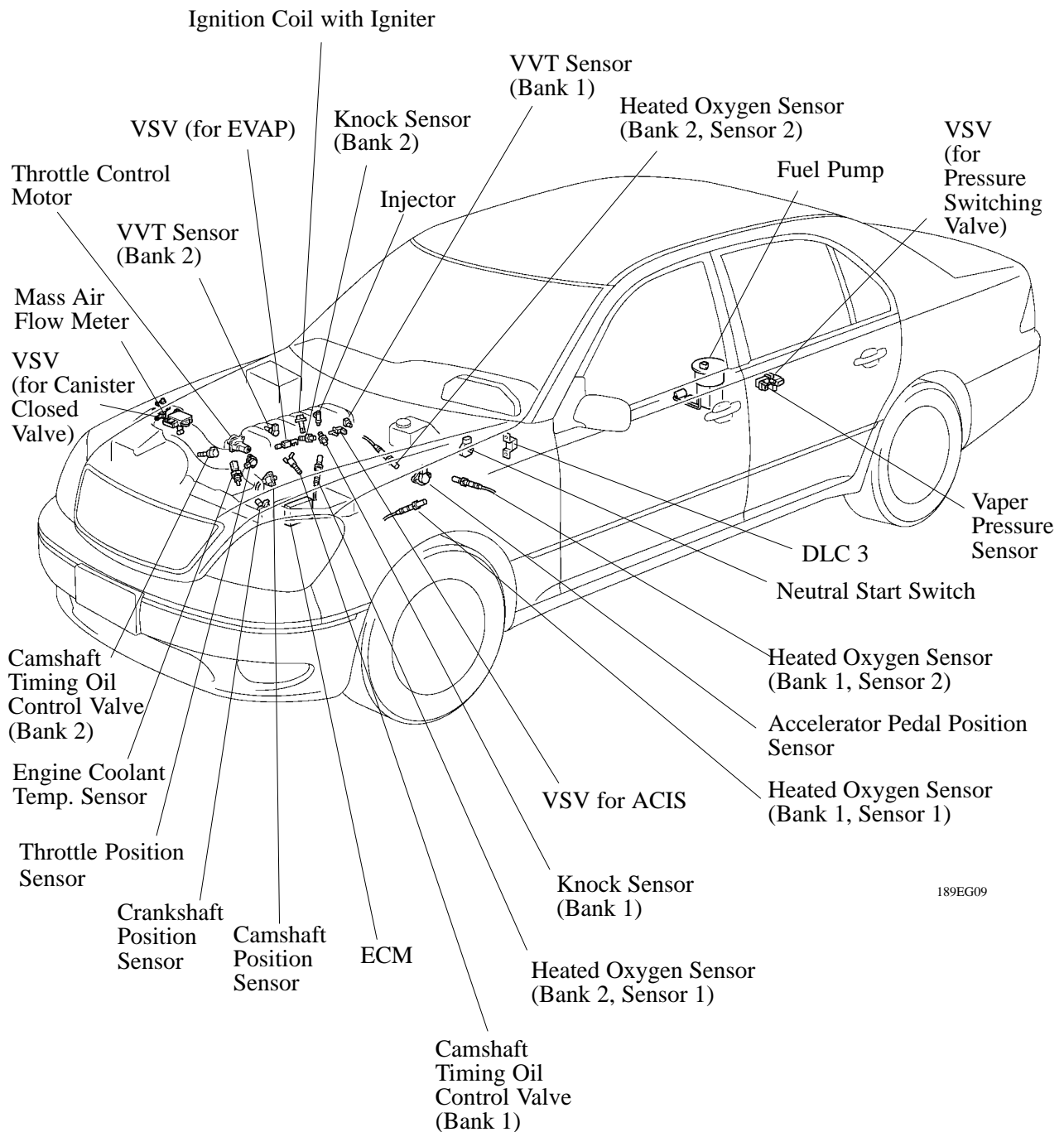

7.5. Main Components of Engine Control System

General

The following table compares the main components of the 3UZ-FE engine in the '01 LS430 and 1UZ-FE engine in the '00 LS400.

Engine Type Components	3UZ-FE		1UZ-FE	
	Outline	Quantity	Outline	Quantity
Mass Air Flow Meter	Hot-Wire Type	1	×	
Crankshaft Position Sensor (Rotor Teeth)	Pick-Up Coil Type (36-2)	1	×	
Camshaft Position Sensor (Rotor Teeth)	Pick-Up Coil Type (1)	1	×	
VVT Sensor	Pick-Up Coil Type (3)	2	×	
Throttle Position Sensor	Linear Type	2	×	
Accelerator Pedal Position Sensor	Linear Type	2	×	
Knock Sensor	Built-In Piezoelectric Type	2	×	
Oxygen Sensor (Bank 1, Sensor 1) (Bank 2, Sensor 1) (Bank 1, Sensor 2) (Bank 2, Sensor 2)	With Heater Type	4	×	
Injector	4-Hole Type with Air Assist	8	×	

Mass Air Flow Meter

A hot-wire type mass air flow meter has been adopted. This mass air flow meter, which is a plug-in type, allows a portion of the intake air to flow through the detection area. By directly measuring the mass and the flow rate of the intake air, the detection precision has been improved and the intake air resistance has been reduced.

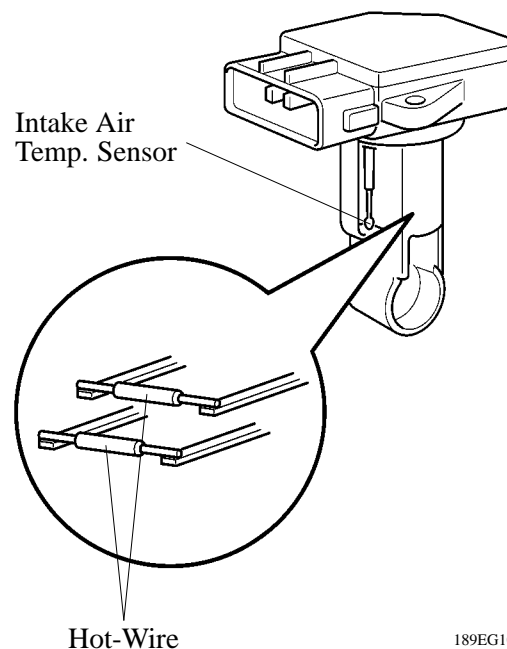

Crankshaft Position Sensor

The timing rotor of the crankshaft consists of 34 teeth, with 2 teeth missing. The crankshaft position sensor outputs the crankshaft rotation signals every 10°, and the missing teeth are used to determine the top-dead-center.

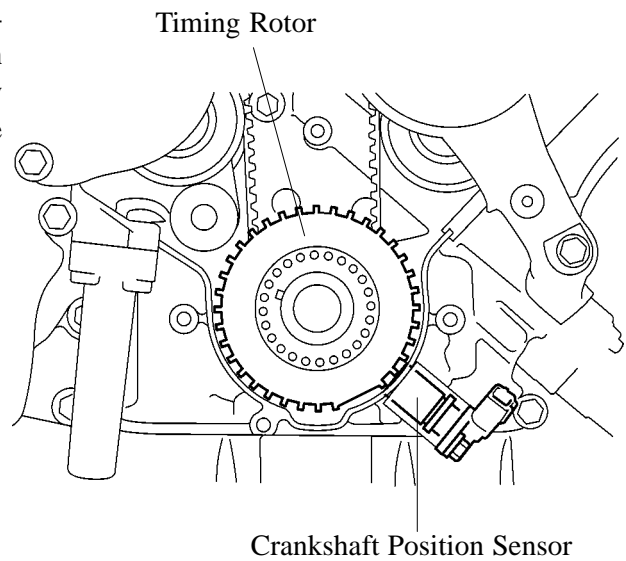

151EG18

Camshaft Position Sensor

The camshaft position sensor is mounted on the left bank cylinder head. To detect the camshaft position, a protrusion that is provided on the timing pulley is used to generate 1 pulse for every 2 revolutions of the crankshaft.

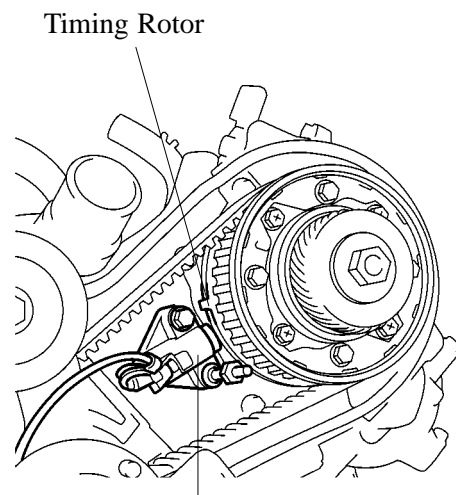

151EG19

VVT Sensor

A VVT sensor is mounted on the intake side of each cylinder head. To detect the camshaft position, a timing rotor that is provided on the intake camshaft is used to generate 3 pulses for every 2 revolutions of the crankshaft.

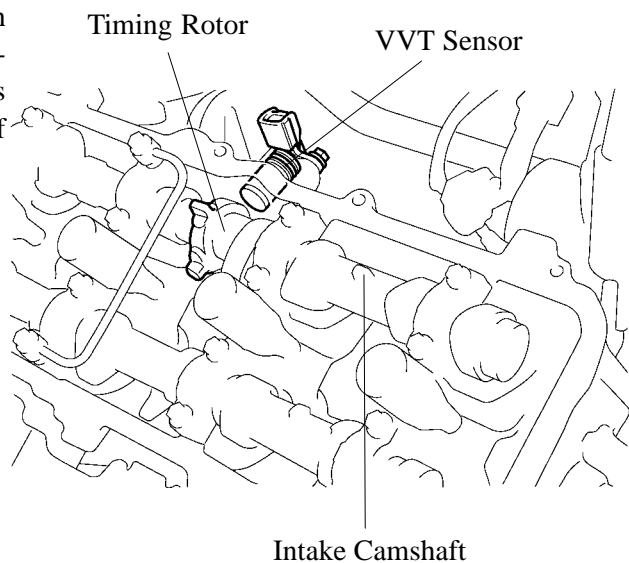

151EG20

7.6. VVT-i (Variable Valve Timing-intelligent) System

General

The VVT-i system is designed to control the intake camshaft within a wide range of 45° (of crankshaft angle) to provide a valve timing that is optimally suited to the engine condition, thus realizing improved torque in all the speed ranges and fuel economy, and reduce exhaust emissions.

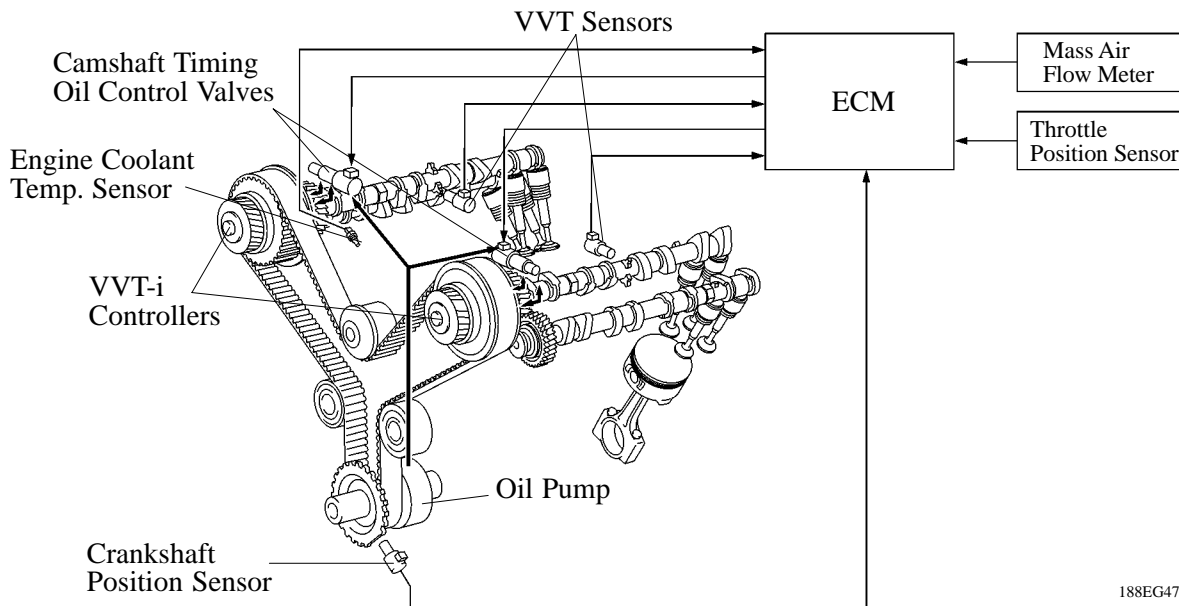

188EG47

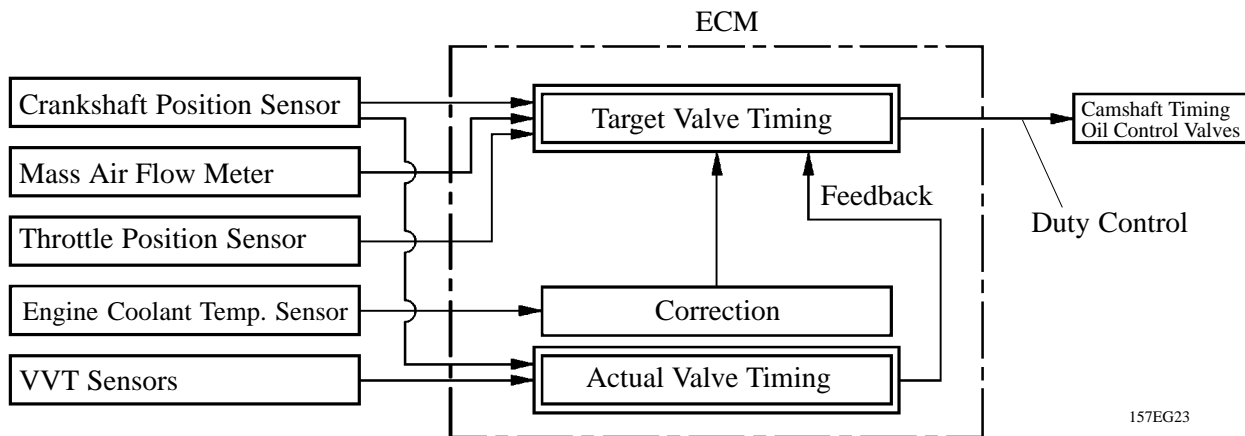

157EG23

1) VVT-i Controller

The VVT-i controller comprises the outer gear that is driven by the timing belt, the inner gear that is affixed to the camshaft and a movable piston that is placed between the outer gear and inner gear. Having helical splines (twisted, vertical grooves) on its inner and outer periphery, the piston moves in the axial direction to shift the phase of the outer gear and inner gear, thus causing the valve timing to change continuously.

The VVT tube drives the exhaust camshaft via the scissors gear that is installed on the back.

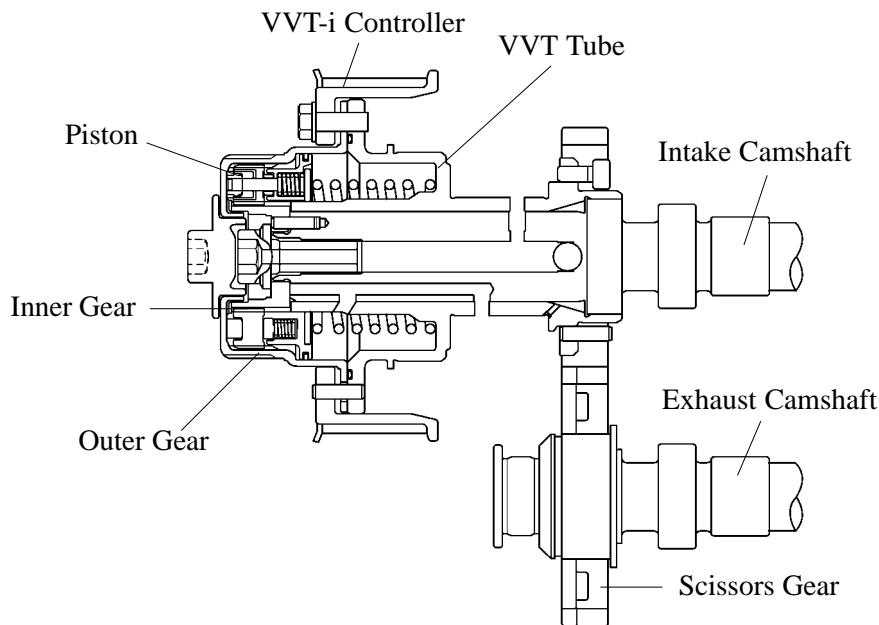

151EG29

2) Camshaft Timing Oil Control Valve

The camshaft timing oil control valve controls the spool valve position in accordance with the duty control from the ECM thus allocating the hydraulic pressure that is applied to the VVT-i controller to the advance and the retard side. When the engine is stopped, the camshaft timing oil control valve is in the most retarded state.

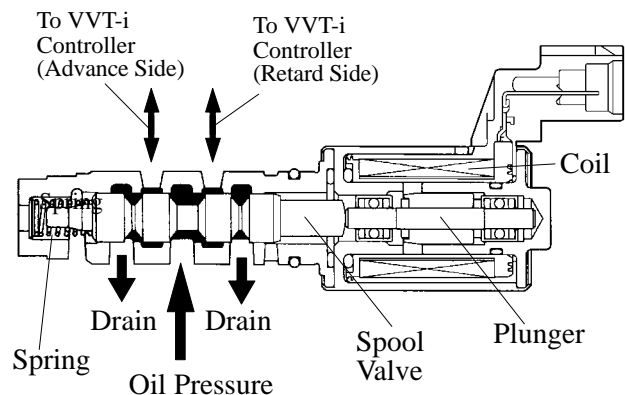

165EG34

76Operation

- The camshaft timing oil control valve selects the path to the VVT-i controller according to the advance, retard or hold signal from the ECM. The VVT-i controller rotates the intake camshaft in the timing advance or retard position or holds it according to the position where the oil pressure is applied.

	Operation	Camshaft Timing Oil Control Valve Drive Signal	Description
Advance	<p>188EG48</p>	<p>Advance Signal</p> <p>Duty Ratio</p> <p>157EG35</p>	<p>When the camshaft timing oil control valve is positioned as illustrated in accordance with the advance signal from the ECM, the oil pressure is applied to the chamber at the advance side. Then, the twist of the helical spline causes the camshaft to rotate in the direction of timing advance.</p>
Retard	<p>188EG49</p>	<p>Retard Signal</p> <p>Duty Ratio</p> <p>157EG36</p>	<p>When the camshaft timing oil control valve is positioned as illustrated in accordance with the retard signal from the ECM, the oil pressure is applied to the chamber at the retard side. Then, the twist of the helical spline causes the camshaft to rotate in the direction of timing retard.</p>
Hold	<p>188EG50</p>	<p>Hold Signal</p> <p>Duty Ratio</p> <p>157EG37</p>	<p>The ECM calculates the target timing angle according to the traveling state to perform control as described above. After setting at the target timing, the valve timing is held by keeping the camshaft timing oil control valve in the neutral position unless the traveling state changes. This adjusts the valve timing at the desired target position and prevents the engine oil from running out when it is unnecessary.</p>

ENGINE — 3UZ-FE ENGINE

● In proportion to the engine speed, intake air volume, throttle position and water temperature, the ECM calculates an optimal valve timing under each driving condition and control the camshaft timing oil control valve. In addition, ECM uses signal from the VVT sensors and the crankshaft position sensor to detect the actual valve timing, thus performing feed back control to achieve the target valve timing.

● **Operation During Various Driving Condition (Conceptual Diagram) ◀**

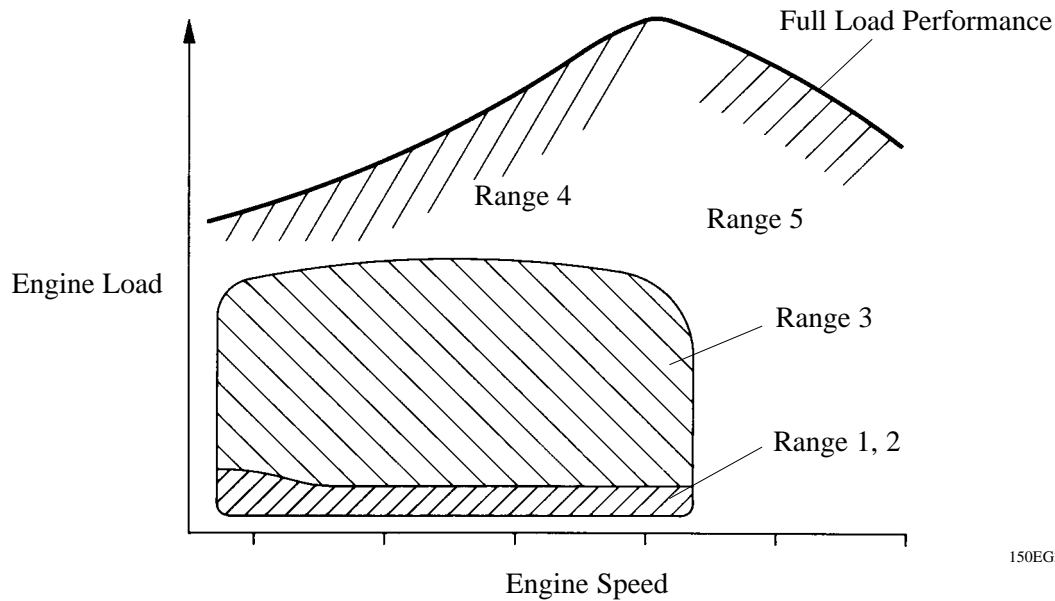

150EG34

Operation State	Range	Valve Timing	Objective	Effect
During Idling	1	<p style="text-align: center;">TDC Latest Timing EX IN BDC 188EG51</p>	Eliminating overlap to reduce blow back to the intake side	Stabilized idling rpm Better fuel economy
At Light Load	2	<p style="text-align: center;">To Retard Side EX IN 188EG64</p>	Decreasing overlap to eliminate blow back to the intake side	Ensured engine stability
At Medium load	3	<p style="text-align: center;">To Advance Side EX IN 188EG65</p>	Increasing overlap to increase internal EGR for pumping loss elimination	Better fuel economy Improved emission control

ENGINE — 3UZ-FE ENGINE

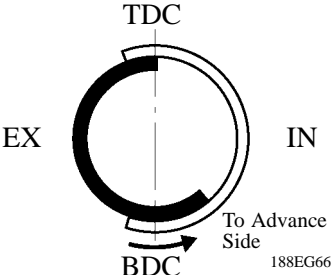
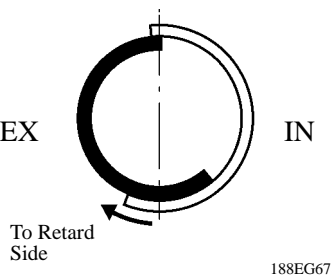
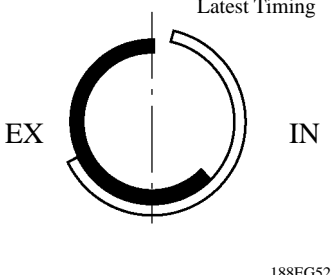
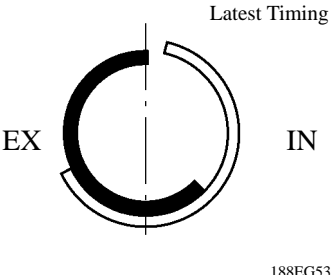
78	Operation State	Range	Valve Timing	Objective	Effect
In Low to Medium Speed Range with Heavy Load	4		Advancing the intake valve close timing for volumetric efficiency improvement	Improved torque in low to medium speed range	
In High Speed Range with Heavy Load	5		Retarding the intake valve close timing for volumetric efficiency improvement	Improved output	
At Low Temperatures	—		Eliminating overlap to prevent blow back to the intake side leads to the lean burning condition, and stabilizes the idling speed at fast idling.	Stabilized fast idle rpm Better fuel economy	
Upon Starting/ Stopping the Engine	—		Eliminating overlap to minimize blow back to the intake side	Improved startability	

7. ETCS-i (Electronic Throttle Control System-intelligent)

79

General

- The ETCS-i system, which realizes excellent throttle control in all the operating ranges, has been adopted. However, in the new 3UZ-FE engine, the accelerator cable has been discontinued, and an accelerator position sensor has been provided on the accelerator pedal. Accordingly, the limp-mode control during the fail-safe mode has been changed.
- In the conventional throttle body, the throttle valve opening is determined invariably by the amount of the accelerator pedal effort. In contrast, the ETCS-i uses the ECM to calculate the optimal throttle valve opening that is appropriate for the respective driving condition and uses a throttle control motor to control the opening.
- The ETCS-i controls the ISC (Idle Speed Control) system, the snow mode control system, the cruise control system, the TRAC (Traction Control) system, and the VSC (Vehicle Skid Control) system. In addition to these controls, a function to control the adaptive laser cruise control has been added to the model with the adaptive laser cruise control.
- The torque-activated power train control has been newly adopted. This control enables the engine to generate the necessary torque as desired by the driver, as well as to realize a smooth engine output characteristic.

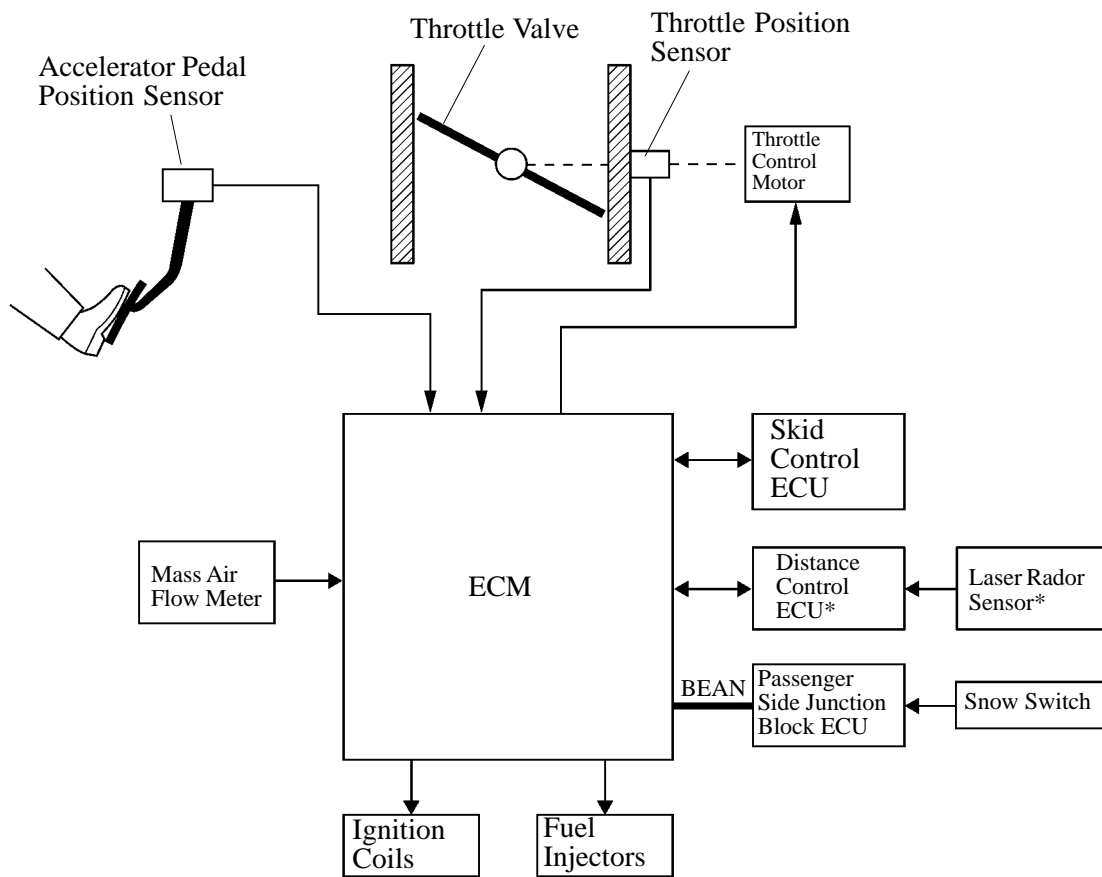

*: with Adaptive Laser Cruise Control

189EG11

80 Construction

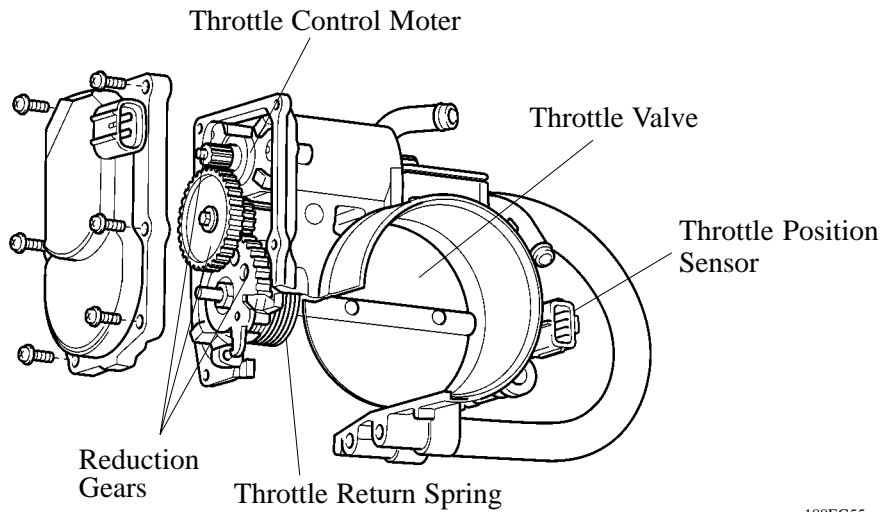

188EG55

1) Accelerator Pedal Position Sensor

The accelerator pedal position sensor is attached to the accelerator pedal. This sensor converts the accelerator pedal depressed angles into electric signals with two differing characteristics and outputs them to the ECM. One is the VPA signal that linearly outputs the voltage along the entire range of the accelerator pedal depressed angle. The other is the VPA2 signal that outputs an offset voltage.

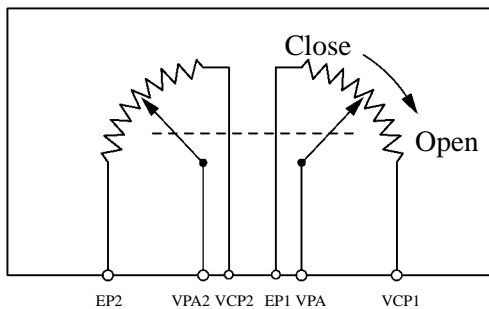

188EG56

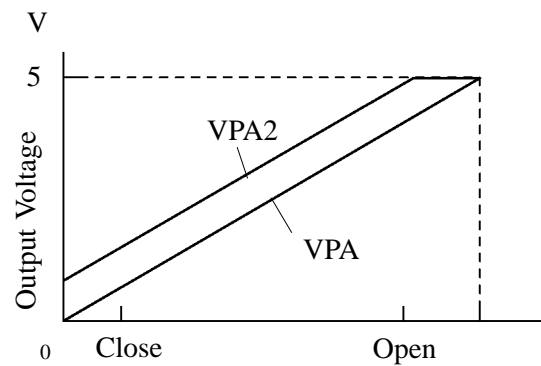

Accelerator Pedal Depressed Angle

188EG57

2) Throttle Position Sensor

81

The throttle position sensor is attached to the throttle body. This sensor converts the throttle valve opening angles into electric signals with two differing characteristics and outputs them to the ECM. One is the VTA signal that linearly outputs the voltage along the entire range of the throttle valve opening angle. The other is the VTA2 signal that outputs an offset voltage.

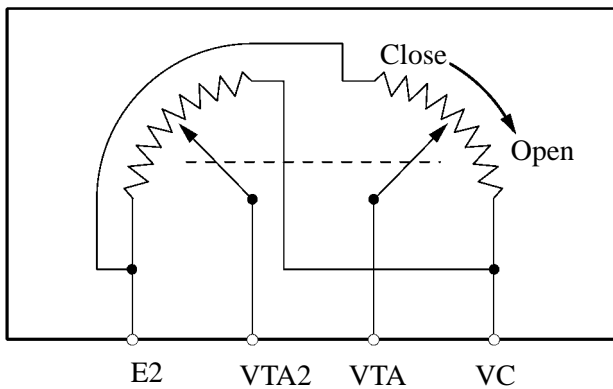

150EG40

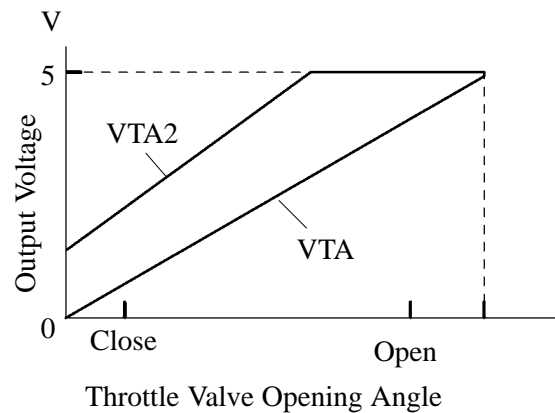

150EG39

3) Throttle Control Motor

A DC motor with excellent response and minimal power consumption is used for the throttle control motor. The ECM performs the duty ratio control of the direction and the amperage of the current that flows to the throttle control motor in order to regulate the opening angle of the throttle valve.

82 Operation

The ECM drives the throttle control motor by determining the target throttle valve opening in accordance with the respective operating condition.

In addition to the controls listed below, functions to effect torque-activated power train control and radar cruise control (on models with adaptive laser cruise control) have been added.

- 1) Torque Activated Power Train Control × New Control
- 2) Nomal-mode Control, Power-mode control and Snow-mode Control
- 3) Idle Speed Control
- 4) Shift Shock Reduction Control
- 5) TRAC Throttle Control
- 6) VSC Coordination Control
- 7) Cruise Control
- 8) Adaptive Laser Cruise Control × New Control

1) Torque Activated Power Train Control

Controls the throttle to an optimal throttle valve opening that is appropriate for the driving condition such as the amount of the accelerator pedal effort and the engine operating condition. As a result, excellent throttle control and comfort in all operating ranges, as well as smooth startoff acceleration and elastic acceleration have been achieved.

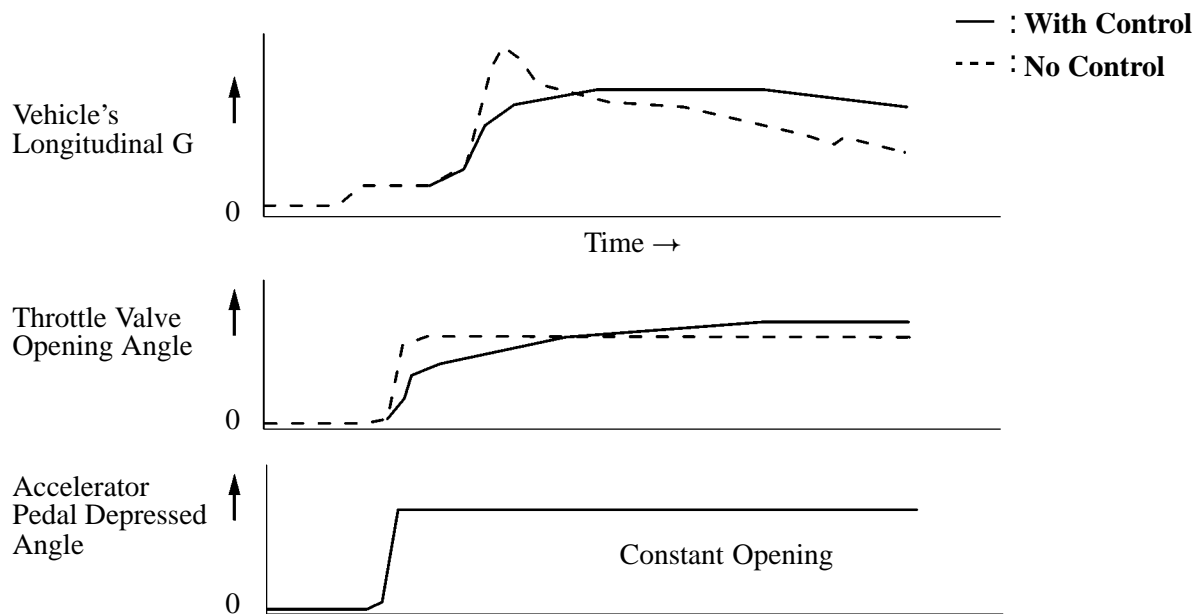

- Controls the throttle to an optimal throttle valve opening that is appropriate for the driving condition such as the amount of the accelerator pedal effort and the engine operating condition in order to realize excellent throttle control and comfort in all operating ranges.
- If turning ON the POWER switch of the pattern select switch and selecting the power-mode, the throttle valve opening angle is controlled to react more directly to operation of the accelerator pedal than the normal mode. With this, sporty driving is realized.
- In situations in which low- μ surface conditions can be anticipated, such as when driving in the snow, the throttle valve can be controlled to help vehicle stability while driving over the slippery surface. This is accomplished by turning on the SNOW switch of the pattern select switch, which, in response to the amount of the accelerator pedal effort that is applied, reduces the engine output from that of the normal driving level.

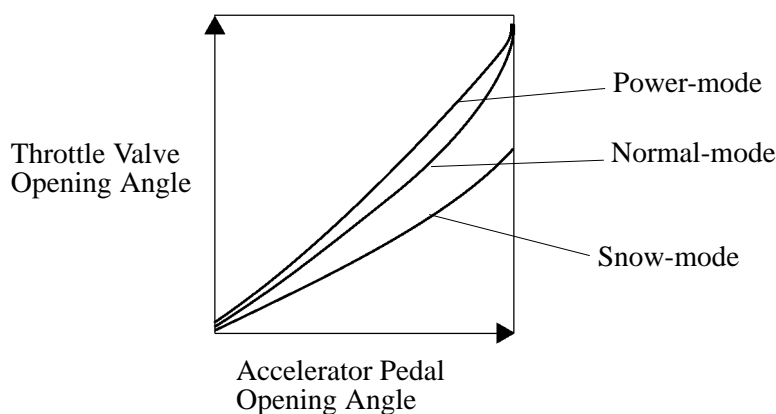

189EG38

Conceptual Diagram**3) Idle Speed Control**

Controls the ECM and the throttle valve in order to constantly effect ideal idle speed control.

4) Shift Shock Reduction Control

The throttle control is synchronized to the ECT (Electronically Controlled Transmission) control during the shifting of the transmission in order to reduce the shift shock.

5) TRAC Throttle Control

As part of the TRAC system, the throttle valve is closed by a demand signal from the skid control ECU if an excessive amount of slippage is created at a driving wheel, thus facilitating the vehicle in ensuring stability and driving force.

6) VSC Coordination Control

In order to bring the effectiveness of the VSC system control into full play, the throttle valve opening angle is controlled by effecting a coordination control with the skid control ECU.

7) Cruise Control

An ECM with an integrated cruise control ECU directly actuates the throttle valve to effect the operation of the cruise control.

84 8) Adaptive Laser Cruise Control

In addition to the functions provided by the conventional cruise control, the adaptive laser cruise control uses a laser radar sensor and a distance control ECU to determine the distance of the vehicle driven ahead, its direction, and relative speed. Thus, the system can effect deceleration cruising control, follow-up cruising control, cruising at a fixed speed control, and acceleration cruising control. To make these controls possible, the ECM controls the throttle valve.

Fail-Safe

If an abnormal condition occurs with the ETCS-i system, the malfunction indicator lamp in the combination meter illuminates to inform the driver.

The accelerator pedal position sensor comprises two sensor circuits. Therefore, if an abnormal condition occurs in the accelerator pedal position sensor, and the ECM detects the abnormal voltage difference of the signals between these two sensor circuits, the ECM transfers to the limp mode by limiting the accelerator opening signal.

If an abnormal condition occurs in the throttle body system which comprises two sensor circuits, the ECM detects the abnormal voltage difference of the signals between these two circuits and cuts off the current to the throttle motor, causing the throttle valve to close. However, when the throttle motor is OFF, because a return spring is provided in the throttle valve, the force of the spring keeps the throttle valve slightly open from the fully closed state. In this state, fuel injection control and ignition timing retard control are effected in accordance with the accelerator opening, thus enabling the vehicle to be operated within the range of idling and limp mode.

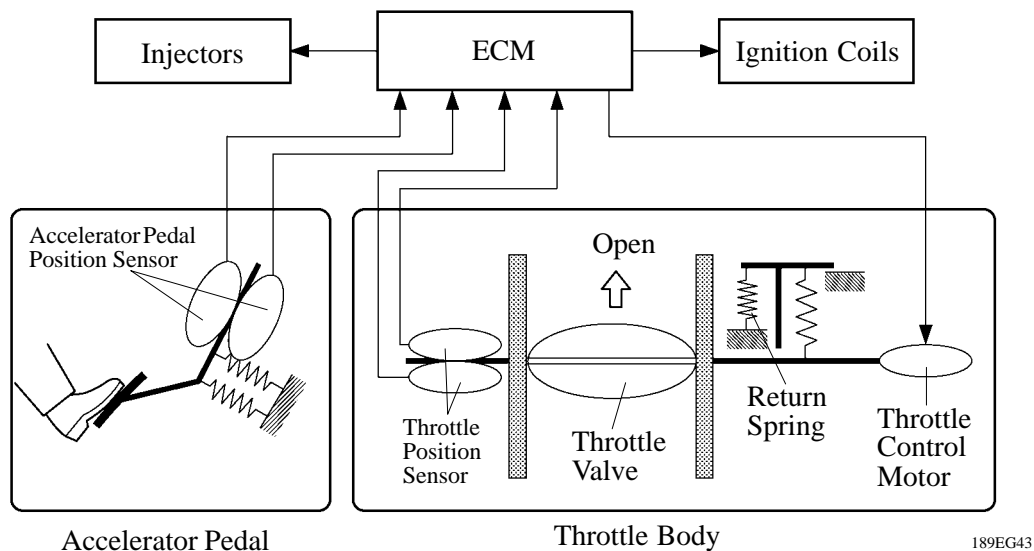

Diagnosis

The diagnostic trouble codes can be output to a LEXUS hand-held tester via the DLC 3. For details, refer to the 2001 LEXUS LS430 Repair Manual (Pub. No. RM812U).

8. ACIS (Acoustic Control Induction System)

85

General

The ACIS (Acoustic Control Induction System) is realized by using a bulkhead to divide the intake manifold into 2 stages, with an intake air control valve in the bulkhead being opened and closed to vary the effective length of the intake manifold in accordance with the engine speed and throttle valve opening angle. This increases the power output in all ranges from low to high speed.

- System Diagram ◀

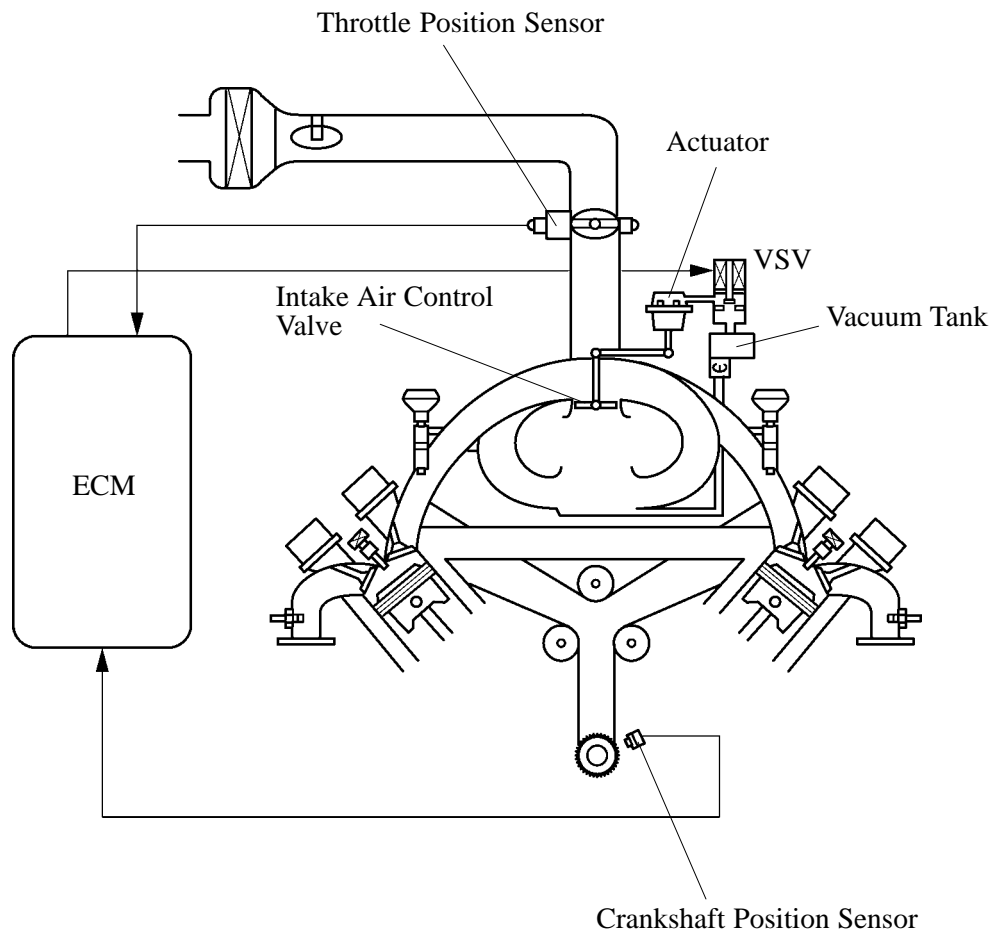

151EG13

86 Construction

1) Intake Air Control Valve

The intake air control valve, which is provided in the middle of the intake manifold in the intake air chamber, opens and closes to change the effective length of the intake manifold in two stages.

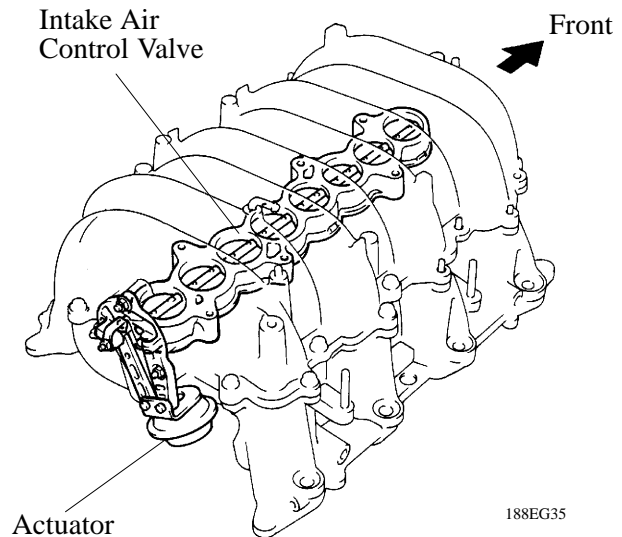

2) VSV (Vacuum Switching Valve)

Controls the vacuum that is applied to the actuator by way of the signal (ACIS) that is output by the ECM.

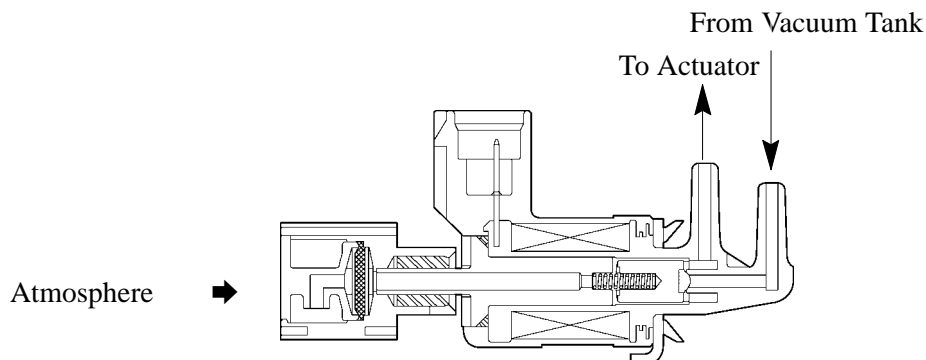

3) Vacuum Tank

Equipped with an internal check valve, the vacuum tank stores the vacuum that is applied to the actuator in order to maintain the intake air control valve fully closed even during low-vacuum conditions.

1) When the Intake Control Valve Closes (VSV ON)

The ECM activates the VSV to match the longer pulsation cycle so that the negative pressure acts on the diaphragm chamber of the actuator. This closes the control valve. As a result, the effective length of the intake manifold is lengthened and the intake efficiency in the low-to-medium speed range is improved due to the dynamic effect of the intake air, thereby increasing the power output.

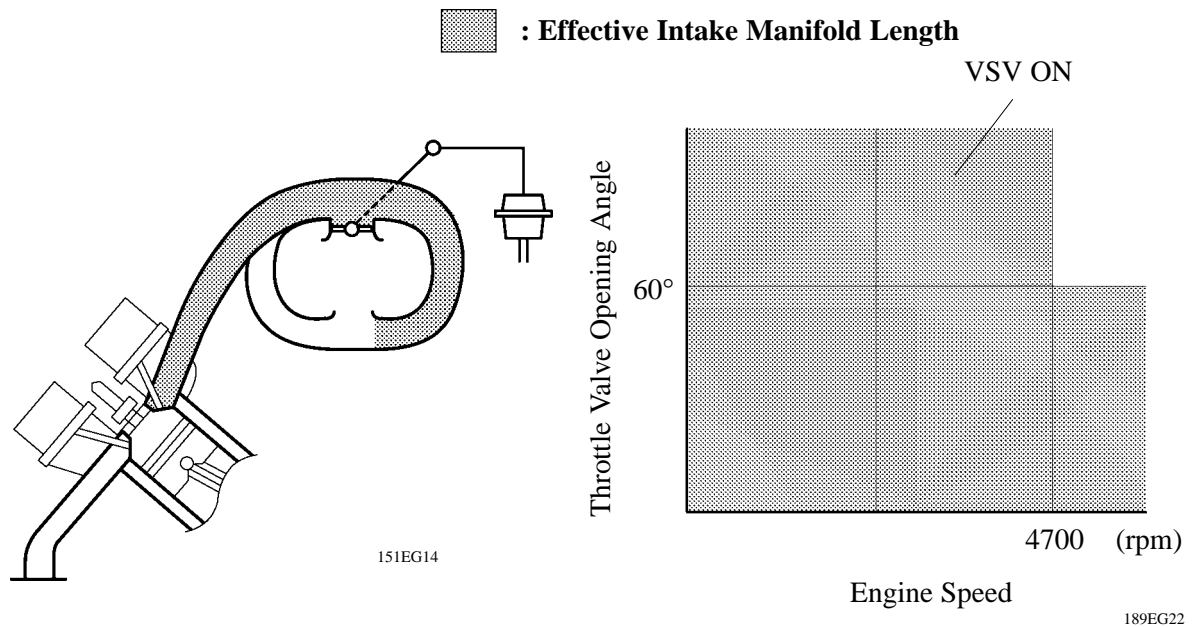

2) When the Intake Control Valve Open (VSV OFF)

The ECM deactivates the VSV to match the shorter pulsation cycle so that atmospheric air is led into the diaphragm chamber of the actuator and opens the control valve. When the control valve is open, the effective length of the intake air chamber is shortened and peak intake efficiency is shifted to the high engine speed range, thus providing greater output at high engine speeds.



: Effective Intake Manifold Length

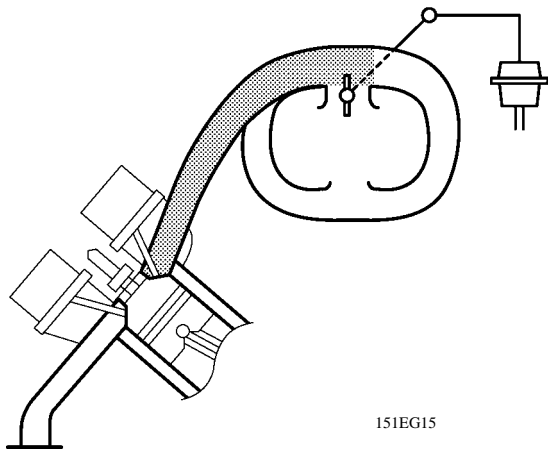

Throttle Valve Opening Angle

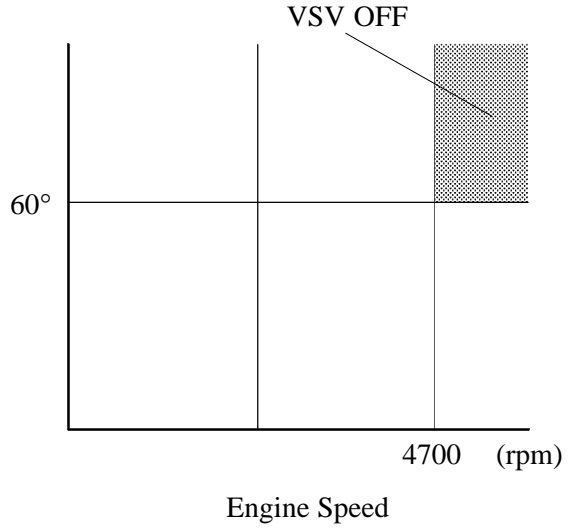

9. Cooling Fan System

General

A cooling fan system has been adopted by the 3UZ-FE engine on the '01 LS430. To achieve an optimal fan speed in accordance with the engine coolant temperature, vehicle speed, engine speed, and air conditioning operating conditions, the ECM calculates the proper fan speed and sends the signals to the cooling fan ECU. Upon receiving the signals from the ECM, the cooling fan ECU actuates the fan motors. Also, the fan speed is controlled by ECM using the stepless control.

- **Wiring Diagram** ◀

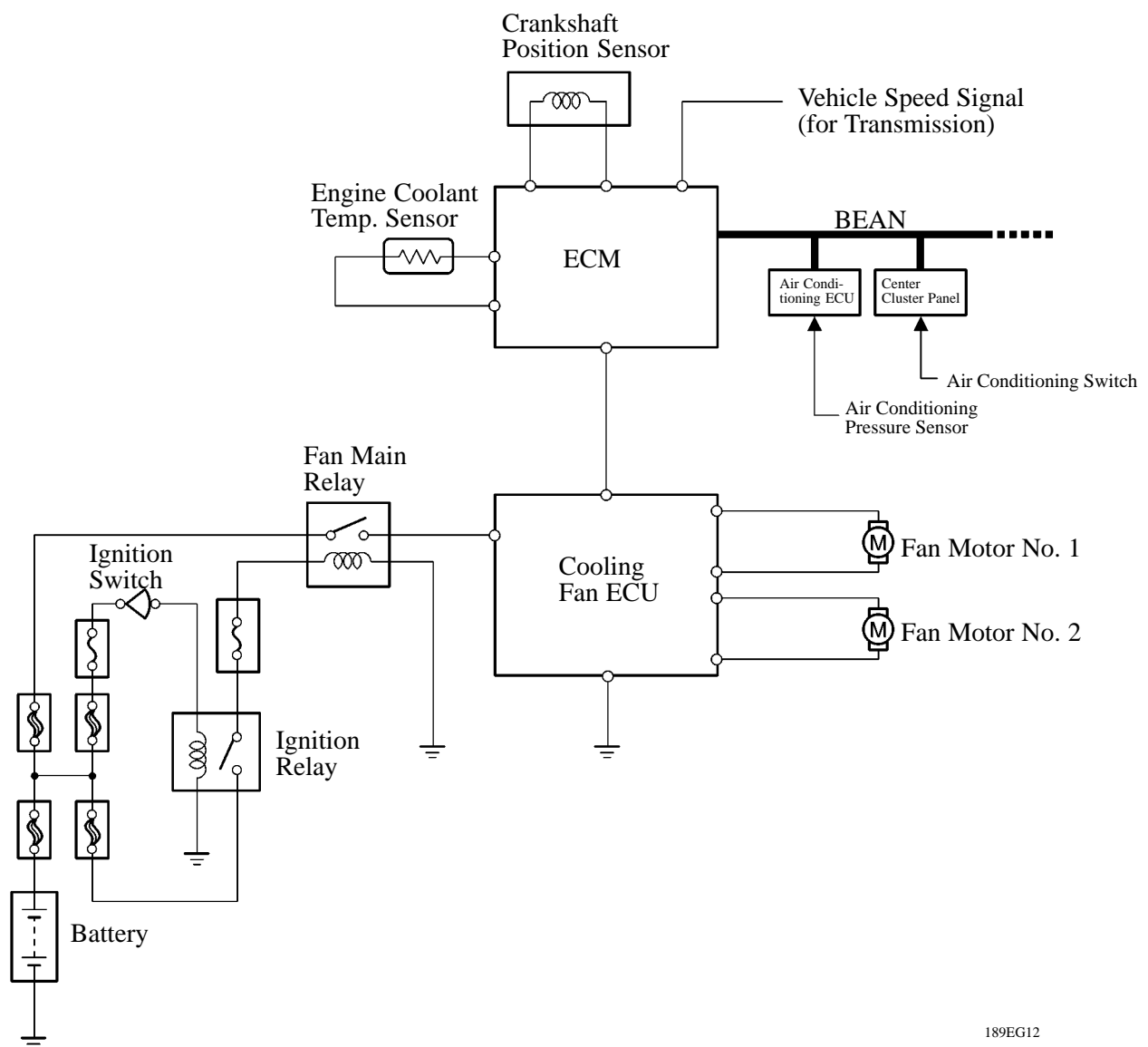

90 Operation

As illustrated below, the ECM determines the required fan speed by selecting the fastest fan speed from among the following:

(A) The fan speed required by the engine coolant temperature, (B) the fan speed required by the air conditioning refrigerant pressure, (C) the fan speed required by the engine speed, and (D) the fan speed required by the vehicle speed.

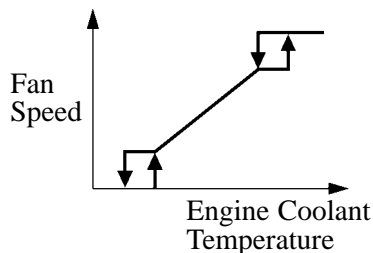

(A) Fan speed required by engine coolant temperature
189EG13

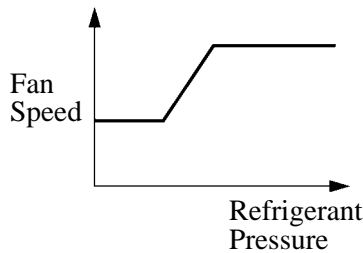

(B) Fan speed required by air conditioning refrigerant pressure
189EG14

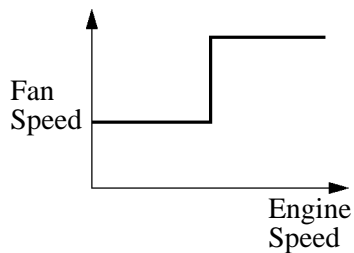

(C) Fan speed required by engine speed
189EG15

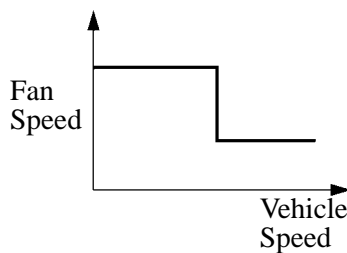

(D) Fan speed required by vehicle speed
189EG16

10. Fuel Pump Control

A fuel cut control is adopted to stop the fuel pump when the airbag is deployed at the front or side collision. In this system, the airbag deployment signal from the airbag sensor assembly is detected by the ECM, which turns OFF the circuit opening relay.

After the fuel cut control has been activated, turning the ignition switch from OFF to ON cancels the fuel cut control, thus engine can be restarted.

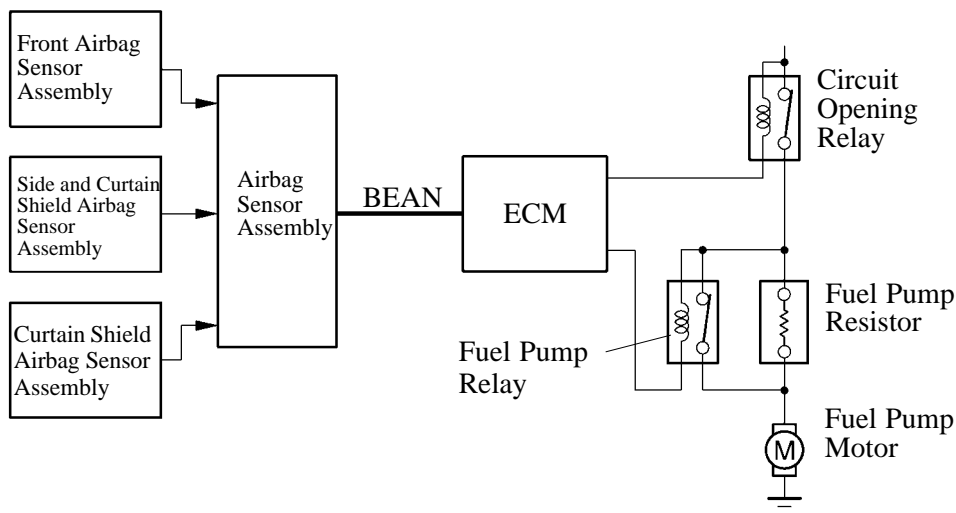

11. Evaporative Emission Control System

91

General

As in the '00 LS400, the vacuum type has been adopted on the '01 LS430 to detect leaks in the evaporative emission control system. This vacuum type detects leaks by forcefully introducing the purge vacuum into the entire system and monitoring the changes in the pressure. It consists of the following main components:

- A VSV (for canister closed valve) that closes the fresh air line from the air cleaner to the charcoal canister has been adopted.
- A VSV (for pressure switching valve) that opens the evaporator line between the fuel tank and the charcoal canister has been adopted.
- Function to close the purge line from the air intake chamber to the charcoal canister for this system is added to the original functions of VSV (for EVAP).
- A vapor pressure sensor that measures the pressure in the fuel tank while checking for evaporative emission leaks and sends signals to the ECM has been adopted.

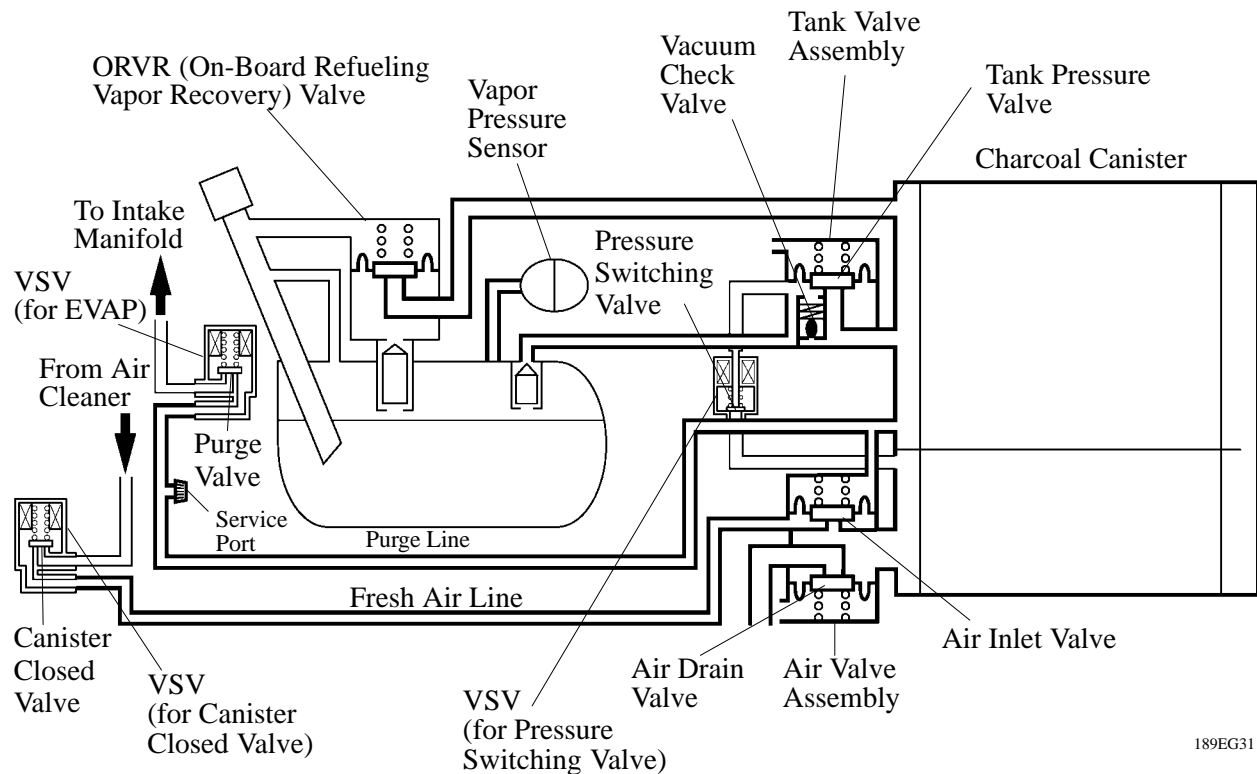

189EG31

92 Operation

1) Purge Flow

When the engine has reached predetermined parameters (closed loop, engine coolant temp. above 74°C (165°F), etc.), stored fuel vapors are purged from the charcoal canister whenever the purge valve is opened by the ECM. At the appropriate time, the ECM will turn on the VSV (for EVAP). The ECM will change the duty ratio cycle of the VSV (for EVAP) thus controlling purge flow volume. Purge flow volume is determined by manifold pressure and the duty ratio cycle of the VSV (for EVAP). Atmospheric pressure is allowed into the canister to ensure that purge flow is constantly maintained whenever purge vacuum is applied to the canister.

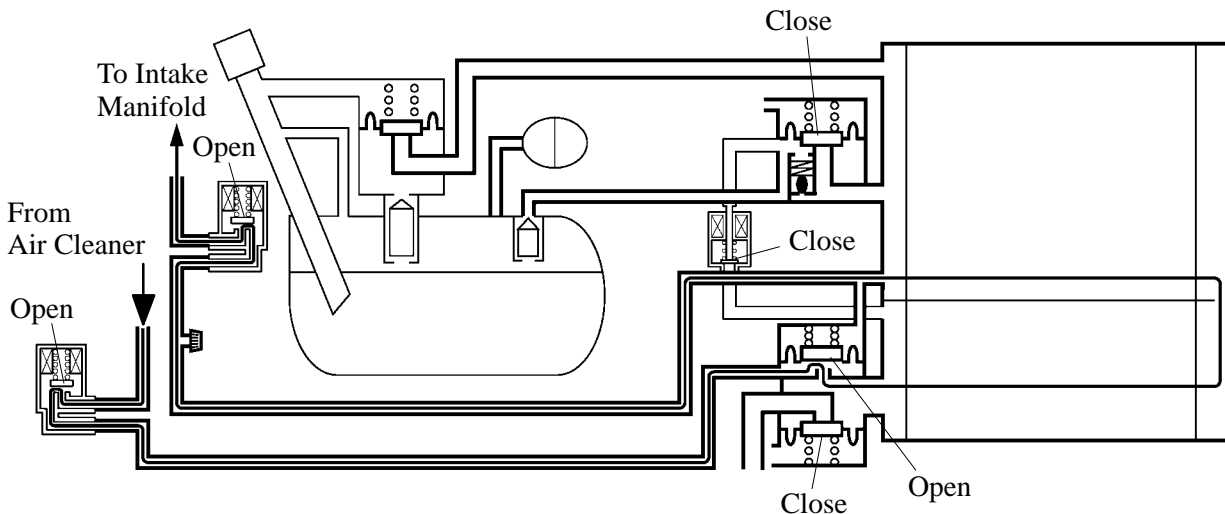

189EG32

2) ORVR (On-Board Refueling Vapor Recovery)

During refueling, low pressure above the diaphragm in the onboard recovery valve lifts allowing fuel vapors into the charcoal canister. At the same time, the air drain valve opens and the charcoal absorbs the fuel vapors.

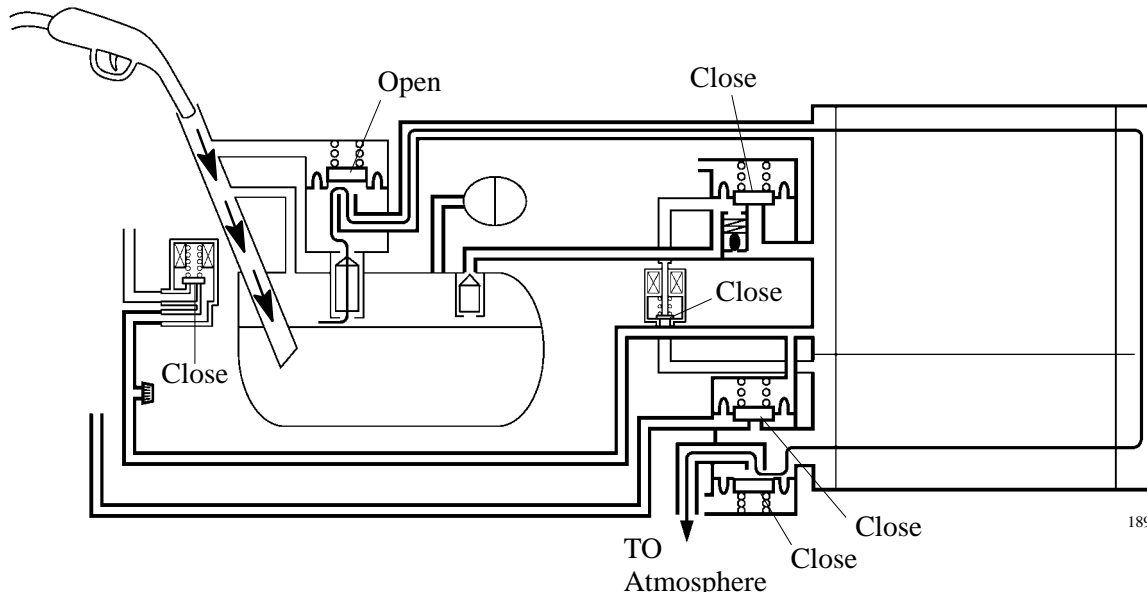

189EG26

3) Monitor

The monitor sequence begins with a cold engine start. The intake air temp. and engine coolant temp. sensors must have approximately the same temperature reading. The ECM is constantly monitoring fuel tank pressure. As the temperature of the fuel increases, pressure slowly rises. The ECM will purge the charcoal canister at the appropriate time. With VSV (for pressure switching valve) closed, pressure will continue to rise in fuel tank.

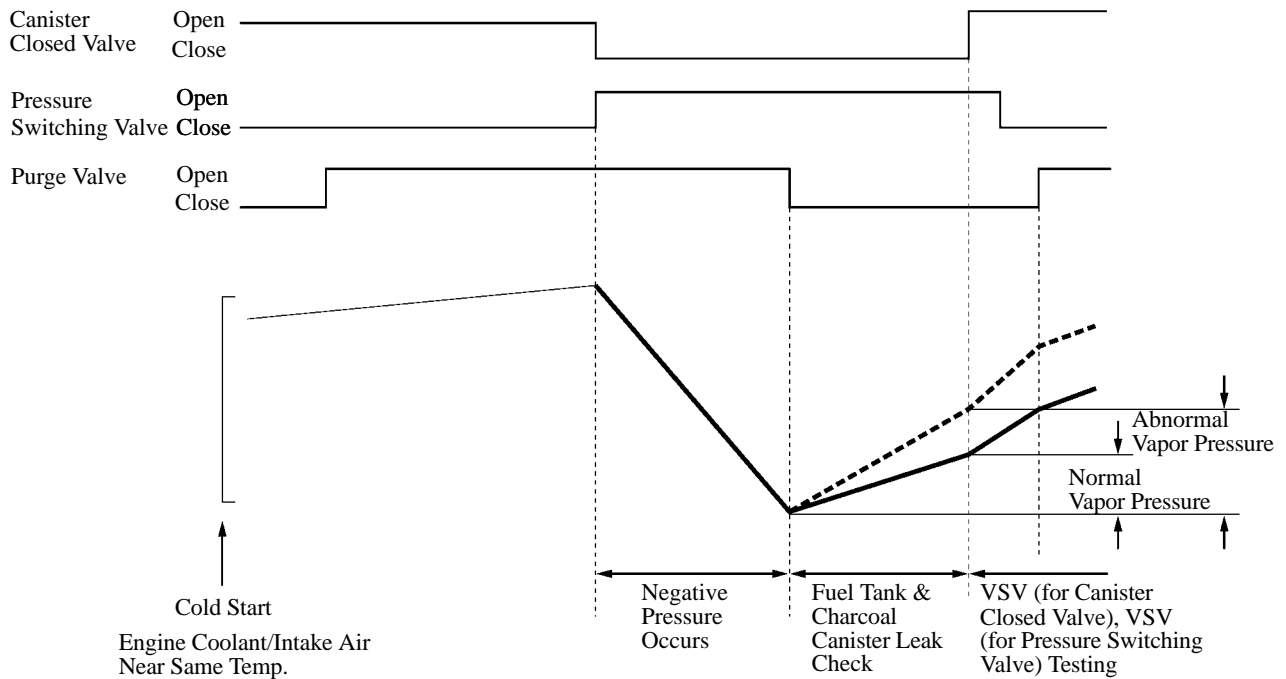
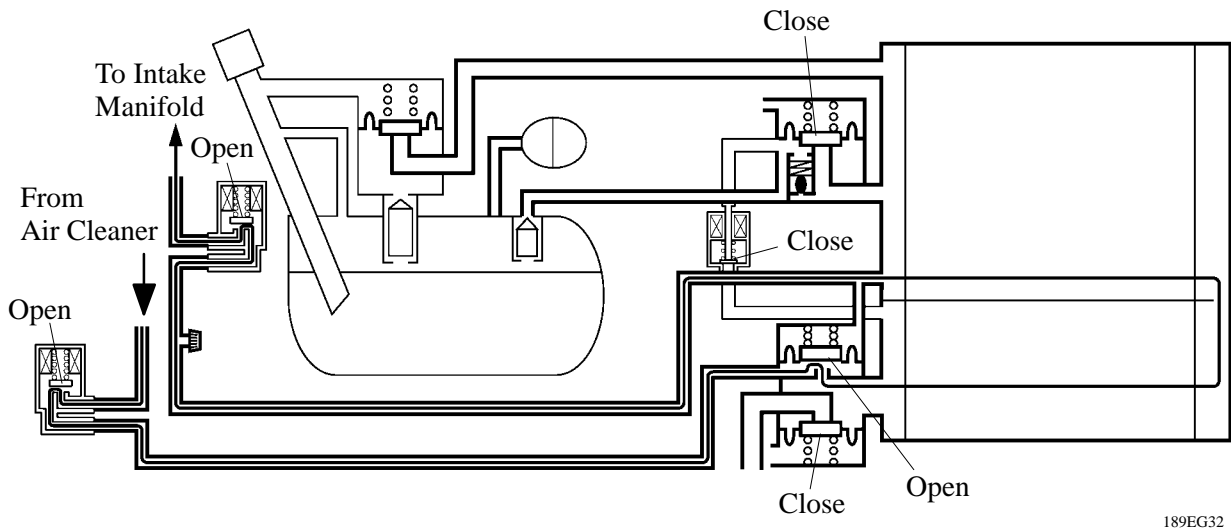

94 4) DTC P0440 (Evaporative Emission Control System Malfunction)

Initially, when the canister closed valve is closed, and the pressure switching valve and the purge valve are opened, a vacuum is applied to the purge line from the air intake to the charcoal canister and to the evaporator line from the charcoal canister to the fuel tank. Next, the purge valve is closed in order to maintain a vacuum from the VSV (for EVAP) to the inside of the fuel tank. Then, any subsequent changes in the pressure are monitored by the vapor pressure sensor in order to check for evaporative emission leaks.

If a leak is detected, the MIL (Malfunction Indicator Lamp) illuminates to inform the driver. Also, the DTC (Diagnostic Trouble Code) can be accessed through the use of a LEXUS hand-held tester.

For details on the DTCs, refer to the 2001 LEXUS LS430 Repair Manual (Pub. No. RM812U).

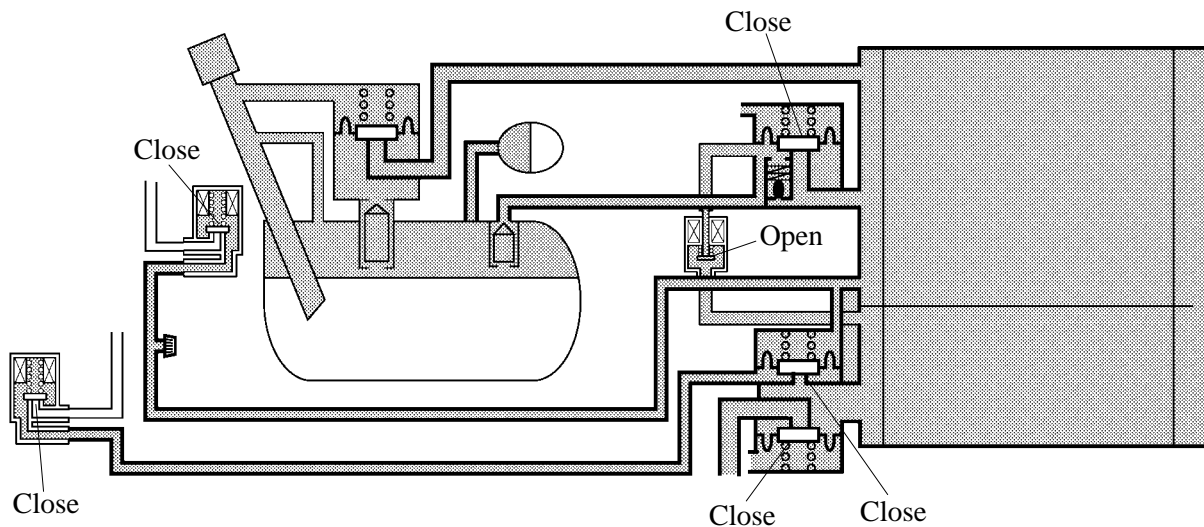

189EG34

5) DTC P0441 (Evaporative Emission Control System Incorrect Purge Flow)

At a predetermined point, the ECM closed the canister closed valve and opens the pressure switching valve causing a pressure drop in the entire EVAP system. The ECM continues to operate the VSV (for EVAP) until the pressure is lowered to a specified point at which time the ECM closed the purge valve. If the pressure did not drop, or if the drop in pressure increased beyond the specified limit, the ECM judges the VSV (for EVAP) and related components to be faulty and the MIL illuminates to inform the driver. Also, the DTC can be accessed through the use of a LEXUS hand-held tester.

For details on the DTCs, refer to the 2001 LEXUS LS430 Repair Manual (Pub. No. RM812U).

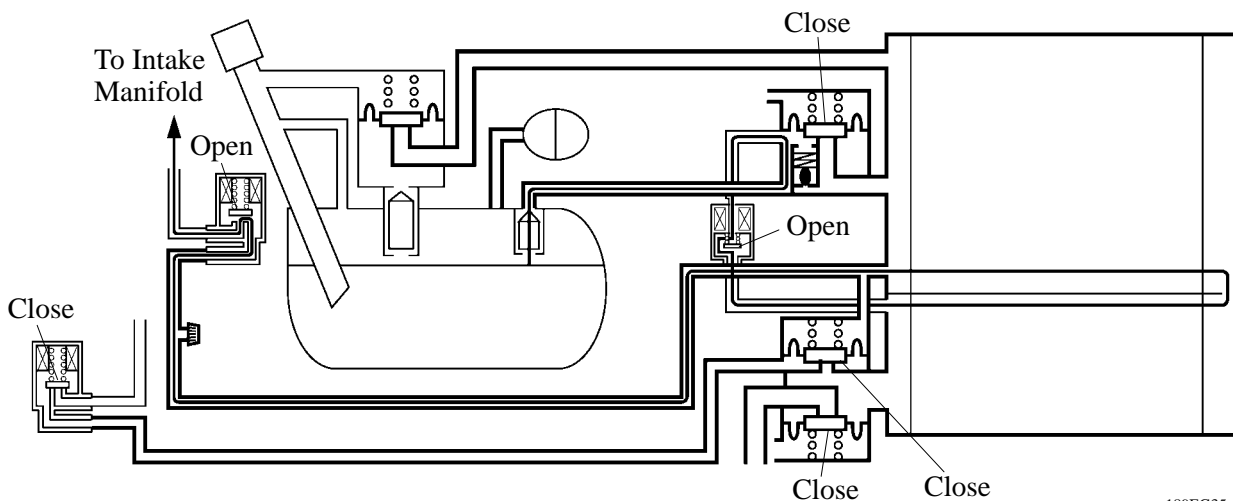

189EG35

a. Canister Closed Valve

This stage checks the VSV (for canister closed valve) and vent (air inlet side) operation. When the vapor pressure rises to a specified pint, the ECM opens the canister closed valve. Pressure will increase rapidly because of the air allowed into the system. No increase or an increase below specified rate of pressure increase indicates a restriction on the air inlet side. If a malfunction is detected, the MIL illuminates to inform the driver. Also, the DTC can be accessed through the use of a LEXUS hand-held tester. For details on the DTCs, refer to the 2001 LEXUS LS430 Repair Manual (Pub. No. RM812U).

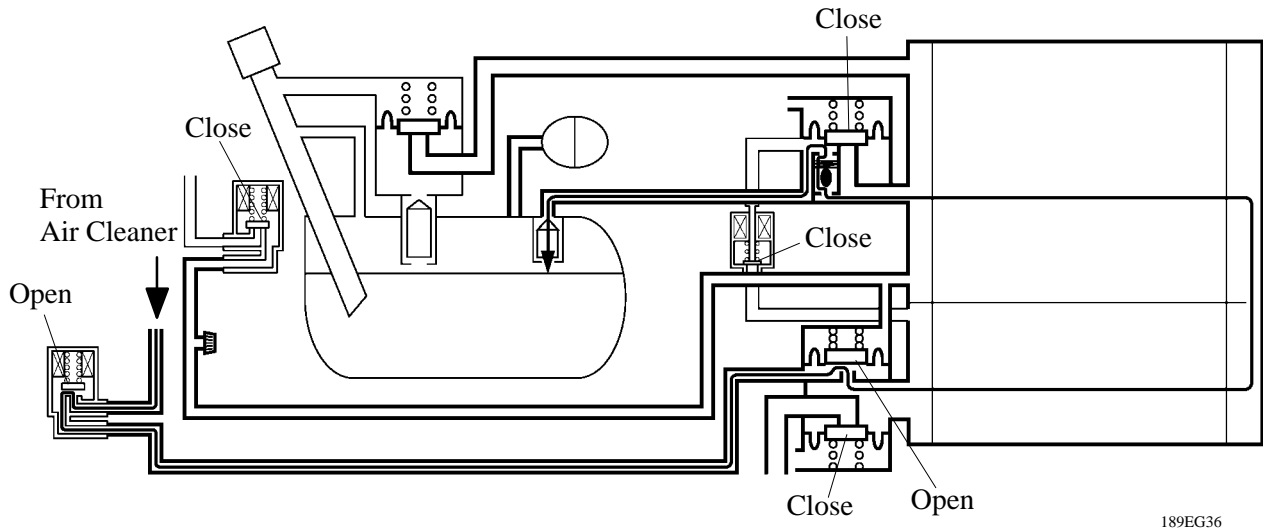

b. Pressure Switching Valve

The ECM closes the pressure switching Valve. This action blocks air entering the tank side of the system. The pressure rise is no longer as great. If there was no change in pressure, the ECM will conclude the pressure switching valve did not close. If a malfunction is detected, the MIL illuminates to inform the driver. Also, the DTC can be accessed through the use of a LEXUS hand-held tester. For details on the DTCs, refer to the 2001 LEXUS LS430 Repair Manual (Pub. No. RM812U).

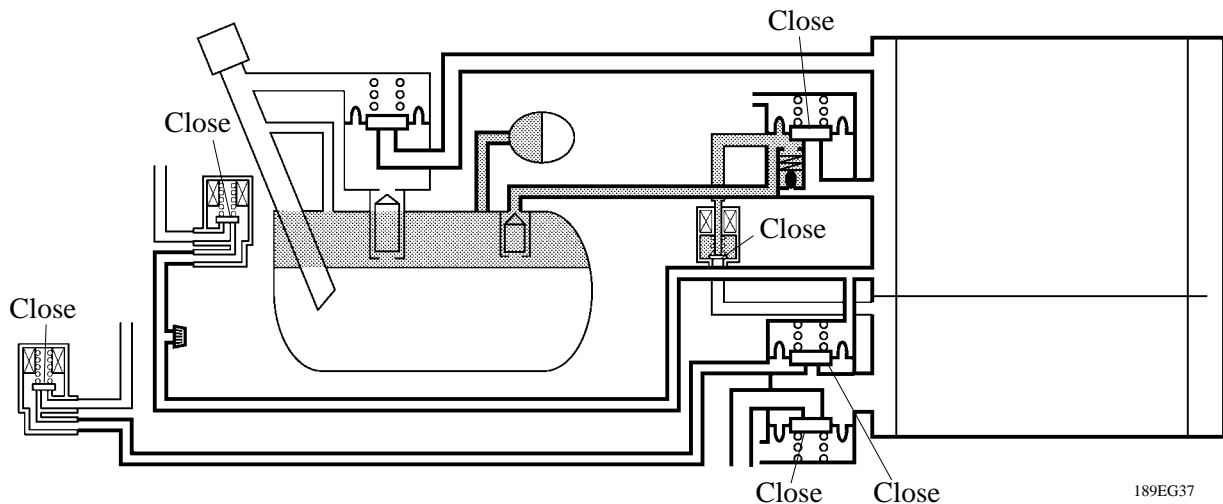

MAJOR TECHNICAL SPECIFICATIONS

Item	Area		U.S.A.	Canada	
	Body Type		4-Door Sedan		
	Vehicle Grade		—		
	Model Code		UCF30L-AEAGKA	UCF30L-AEAGKK	
Major Dimension & Vehicle Weights	Overall	Length	mm (in.)	4995 (196.7)	←
		Width	mm (in.)	1830 (72.0)	←
		Height*	mm (in.)	1490 (58.7), 1470 (57.9)* ¹	←
	Wheel Base		mm (in.)	2925 (115.2)	←
	Tread	Front	mm (in.)	1570 (61.8), 1575 (62.0)* ¹	←
		Rear	mm (in.)	1570 (61.8), 1575 (62.0)* ¹	←
	Effective Head Room	Front	mm (in.)	1005 (33.6), 967 (38.1)* ²	←
		Rear	mm (in.)	963 (37.9), 964 (38.0)* ²	←
	Effective Leg Room	Front	mm (in.)	1118 (44.0)	←
		Rear	mm (in.)	954 (37.6)	←
	Shoulder Room	Front	mm (in.)	1481 (58.3)	←
		Rear	mm (in.)	1479 (58.2)	←
	Overhang	Front	mm (in.)	835 (32.9)	←
		Rear	mm (in.)	1235 (48.6)	←
	Min. Running Ground Clearance		mm (in.)	145 (5.7), 150 (5.9)* ¹	←
	Angle of Approach		degrees	16°, 18° * ¹	←
Angle of Departure		degrees	15°	←	
Curb Weight	Front	kg (lb)	950 (2094)	←	
	Rear	kg (lb)	845 (1863)	←	
	Total	kg (lb)	1795 (3957)	←	
Gross Vehicle Weight	Front	kg (lb)	1115 (2458)	←	
	Rear	kg (lb)	1215 (2679)	1210 (2668)	
	Total	kg (lb)	2330 (5137)	2325 (5126)	
Fuel Tank Capacity	L (US. gal., Imp.gal.)		84 (22.2, 18.5)	←	
Luggage Compartment Capacity	m ³ (cu.ft.)		0.45 (16.0)	←	
Performance	Max. Speed		km/h (mph)	210 (130)	←
	Max. Cruising Speed		km/h (mph)	190 (118)	←
	Acceleration	0 to 60 mph	sec.	6.3	←
		0 to 400 m	sec.	14.7	←
	Max. Permissible Speed	1st Gear	km/h (mph)	68 (42)	←
		2nd Gear	km/h (mph)	104 (65)	←
		3rd Gear	km/h (mph)	160 (99)	←
4th Gear		km/h (mph)	—	—	
Turning Diameter (Outside Front)	Wall to Wall	m (ft.)	11.4 (37.4)	←	
	Curb to Curb	m (ft.)	10.7 (35.1)	←	
Engine	Engine Type		3UZ-FE	←	
	Valve Mechanism		32-Valve, DOHC	←	
	Bore × Stroke	mm (in.)	91.0 × 82.5 (3.58 × 3.25)	←	
	Displacement	cm ³ (cu.in.)	4293 (261.9)	←	
	Compression Ratio		10.5 : 1	←	
	Carburetor Type		SFI	←	
	Research Octane No.	RON	95 or more	←	
	Max. Output (SAE-NET)	kW/rpm (HP@rpm)	216/5600 (290@5600)	←	
Max. Torque (SAE-NET)	N-m/rpm (lb-ft@rpm)	434/3400 (320@3400)	←		
Engine Electrical	Battery Capacity (5HR)	Voltage & Amp. Hr.	12 - 55	←	
	Alternator Output	Watts	1560	←	
	Starter Output	kW	2.0	←	

55

60

Chassis

65

70

Clutch Type		—	—
Transmission Type		A650E	←
Transmission Gear	In First	3.357	←
	In Second	2.180	←
	In Third	1.424	←
Ratio	In Fourth	1.000	←
	In Fifth	0.753	←
	In Reverse	3.431	←
Differential Gear Ratio		3.266	←
Differential Gear Size in.		8"	←
Brake Type	Front	Ventilated Disc	←
	Rear	Ventilated Disc	←
Parking Brake Type		Duo Servo	←
Brake Booster Type and Size in.		Tandem 8.5" + 8.5"	←
Proportioning Valve Type		—	—
Suspension Type	Front	Double Wishbone	←
	Rear	Double Wishbone	←
Stabilizer Bar	Front	STD	←
	Rear	STD	←
Steering Gear Type		Rack & Pinion	←
Steering Gear Ratio (Overall)		15.7	←
Power Steering Type		Integral Type	←

*: Unladen Vehicle *1: With Air Suspension *2: With Moon Roof

Obsessed with superior performance, as well as concern for the environment.

The LS430 contains limitless possibilities.



Engine

The V8 4.3L 3UZ-FE engine has been adopted.

The V8 4.3L 3UZ-FE engine developed through the incorporation of the latest technology, achieving an improvement in total performance by enlarging the bore, based on the 1UZ-FE engine installed in the previous LS400, and improvements of other engine parts.

This engine turns smoothly and runs dynamically. With the VVT-i (Variable Valve Timing-intelligent) system, ACIS (Acoustic Control Induction System), ETCS-i (Electronic Throttle Control System-intelligent) and optimal utilization of their control functions, excellent engine performance is ensured. The engine features good fuel economy, clean exhaust gas performance, and is packed with superior performance features that are just what you would expect from an engine mounted on the LEXUS flagship.

● Outline of the 3UZ-FE Engine ◀

Overall Engine Displacement	cm³ (cu.in.)	4,293 (261.9)
Bore × Stroke	mm (in.)	91 × 82.5 (3.58 × 3.259)
Maximum Output	[SAE-NET]	216 kW @ 5,600 rpm (290 HP @ 5,600 rpm)
Maximum Torque	[SAE-NET]	434 N·m @ 3,400 rpm (320 ft·lbf @ 3,400 rpm)

● Performance Curve ◀

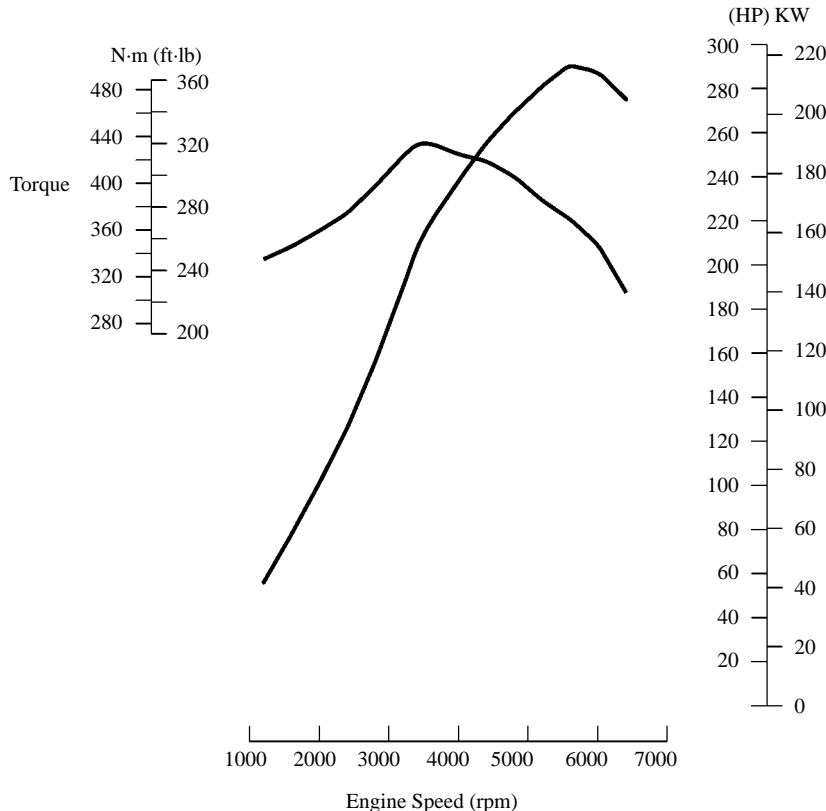

FEATURES OF 3UZ-FE ENGINE

- 1. Powerful in practical range**
- 2. Acceleration without stress**
- 3. Excellent fuel efficiency**
- 4. The engine passes U-LEV (Ultra-Low Emission Vehicle) exhaust emissions requirements**

Item	1	2	3	4
Displacement increased from 4.0 liters to 4.3 liters	•	•		
Adoption of ETCS-i (Electronic Throttle Control System-intelligent)				
VVT-i (Variable Valve Timing-intelligent)	•		•	•
Reduced overall engine weight			•	
Adoption of a thin-walled high-density cell catalytic converter				•
Shorter length exhaust manifolds allows the catalytic converter to be placed closer to the engine				•



Suspension

This is a highly sophisticated suspension that puts polish on supple driving performance.

Front Suspension

A newly refinded high-mount double wishbone suspension has been adopted. Also, by locating the power steering gear assembly in front of the axle, calm, flat running is realized, particularly during high speed driving. The steering angle has also been increased to its maximum, making the minimum turning radius smaller.

Rear Suspension

As with the front suspension, a newly refinded double wishbone suspension has been adopted. By enlarging the stroke, ensuring torsional rigidity and ensuring camber rigidity, flat riding comfort and superior vehicle stability are realized wherever you drive.

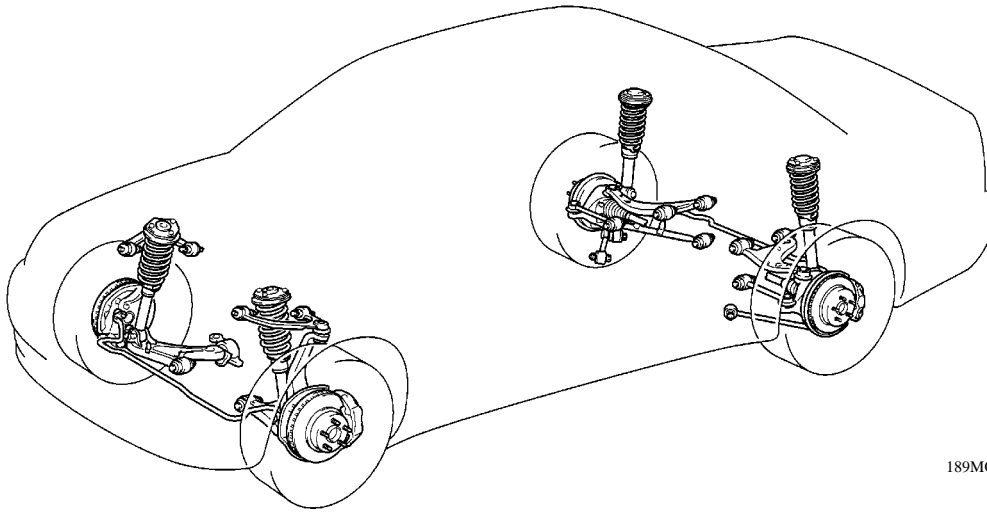

189MO38

Air Suspension (Option)

Combining the features of air springs for extreme suppleness with new shock absorber control functions, the air suspension ensures riding comfort and quietness newer experienced before.

Various technologies have been poured into this car to assure that it is the top class in safety.



Active Safety

To the farthest extent possible, to prevent accidents before they happen.

ABS with EBD (Electronic Brake force Distribution)

In order to prevent the tires from locking during emergency braking and assure vehicle stability and steerability, ABS has been installed. Furthermore, ABS hydraulic control equipment can be used and EBD, which appropriately divides the braking force between the front and rear and between the right and left wheels in accordance with the vehicle's driving state, can be included as a part of a set. With EBD, braking pedal force, particularly when the vehicle is loaded, is lightened, and a superior braking effect and performance can be assured.

TRAC (Traction Control) System

The TRAC is provided to ensure the proper drive force and to achieve excellent straightline performance and cornering stability on slippery roads.

VSC (Vehicle Skid Control)

When hazard avoidance actions are taken and the vehicle's equilibrium is destabilized, the VSC system applies the brakes to the appropriate wheel, generating a yaw moment and this helps to stabilize the vehicle.

Brake Assist

For drivers who cannot pump the brake pedal hard during emergency braking, with this system, in an emergency, brake pedal depressing speed can be accelerated and greater braking force can be generated. Also, when greater braking force is required, high braking pedal depression speed can be achieved, even when the vehicle is loaded.



Passive Safety

We carry on a constant and thorough search to discover and implement various things that can be done to the car to make it safe; just in case.

LEXUS Link (Option for U.S.A.)

If an accident occurs and the airbags are deployed, this system makes an emergency call to a LEXUS link center automatically. And since the vehicle's position is communicated by GPS to LEXUS link center, rescue operations can be conducted smoothly. Even in the event of an accident in which the airbags are not deployed, an emergency call can be placed by button operation.

Furthermore, the following functions are adopted.

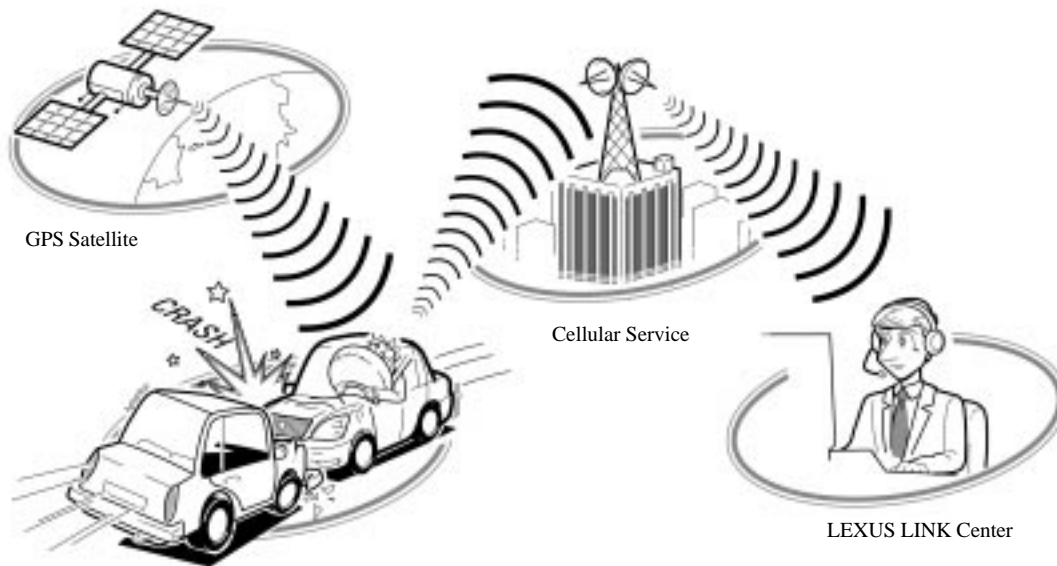

189MO39

- Conversations with the LEXUS link center can be recorded and played back.
- If a driver forgets to lock the door, the user can inform the LEXUS link center, which can then, by remote operation, lock the door.
- If a driver locks the keys in the car, the user can inform the LEXUS link center, which can then, by remote operation, unlock the door.
- When the vehicle is stolen, the Mayday ECU receives a signal from the theft deterrent ECU and, automatically informs the LEXUS link center of the theft, and the vehicle's location by GPS (Global Positioning System).

SRS Airbag System

The LS430 is equipped with SRS (Supplement Restraint System) front airbags and SRS side airbags on both driver and front passenger; it's also equipped with curtain shield airbags, front and rear, to help prevent secondary injuries during collisions.

- **2-stage Airbag System for Front Passenger**

Two newly installed electrical (deceleration sensor) type front airbag sensor assembly mounted on the center floor under the instrument panel.

- **Curtain Shield Airbag (Front/Rear Seat)**

If the sensors, mounted in the bottom of the center pillar and of the rear quarter pillar, detects an impact from the side, a side airbag is deployed, and at the same time, a curtain shield airbag is deployed. This enables the passengers to avoid direct impact to the head from objects inside the car, such as the pillar garnish, and from objects outside the car, such as power poles.

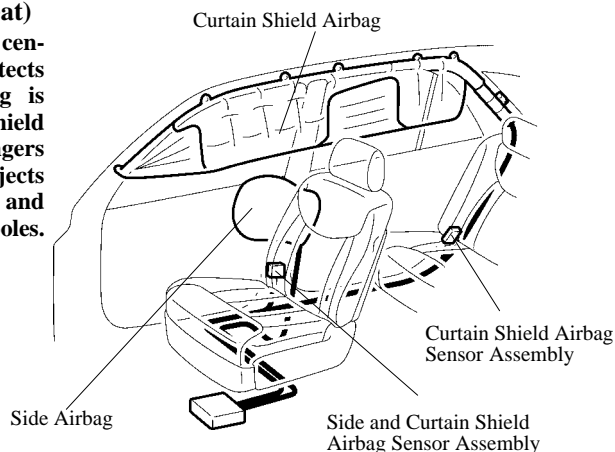

189MO35

Seat Belts with Pretensioner and Force Limiter

Seat belt for the front seats and the rear outside seats are equipped with pretensioners, which snugly restraint the occupants at the time of a collision, and force limiters, which soften the impact to the chest from the seat belt itself.

Head Impact Protection Structure

A head impact protection structure has been adopted. With this type of construction, if the occupant's head hits against the roof side rail and pillar in reaction to a collision, the inner panel of the roof side rail and pillar collapses to help reduce the impact.

Laminated Door Glass (Option)

2-layer laminated glass is used for all the door windows. In the event of an accident, etc., pieces of broken glass are prevented from scattering. Laminated glass can shut out ultraviolet rays approximate 100%, which consequently presents deterioration of interior trim from sunshine.

Impact Absorbing Structure

The impact absorbing body adopted for the new LS430 effectively absorbs and distributes the impact from front and side collision to ease the impact on the driver and passengers, and the high-strength cabin minimizes deformation of the cabin itself.

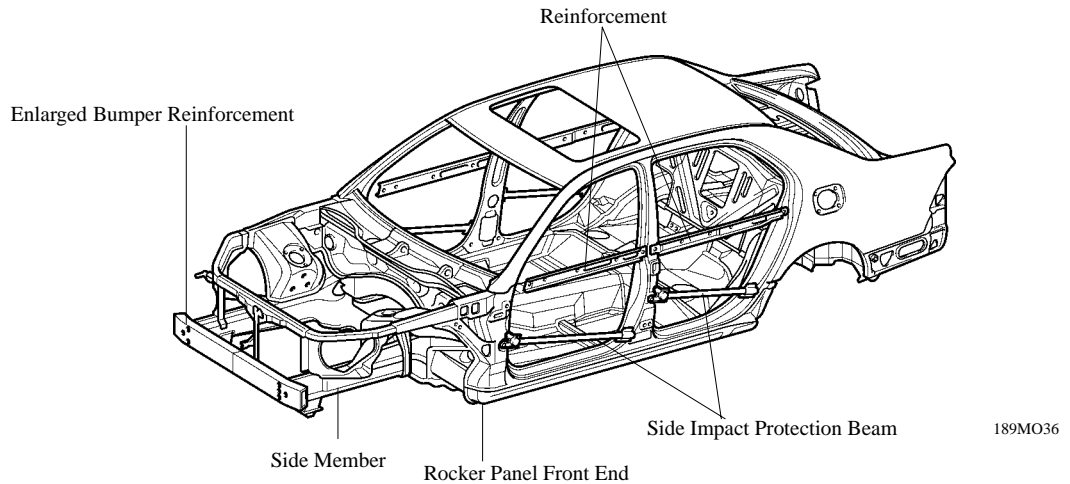

Compatibility

Enlarged bumper reinforcement for impact in wide area of another vehicle for considering harmness. Adopted tailored blank to front side member and front end of member for crushable construction for consideration.

Frontal Collision

The side member, as an impact absorbing structure, strengthens parts connected to the cabin, to minimize cabin deformation.

We raised the edge in front of the rocker panels to create a crumple zone, which enables impact absorption and also minimizes cabin deformation.

Side Collision

Impact absorbing efficiency has been provided by placing a side impact protection beam inside the door, to reinforce it.

The front seat rod and brace have been provided, allowing the energy of a side collision to be transmitted to the floor tunnel in order to minimize the deformation of cabin space.

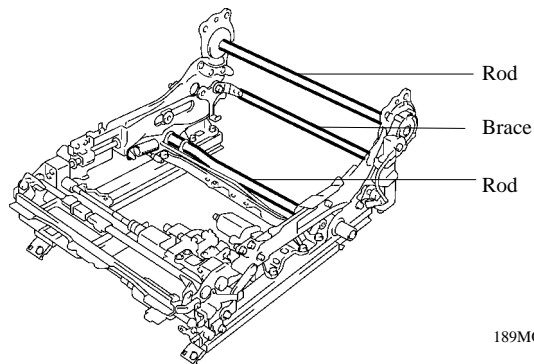

Reasonable Repair Cost

LS430's large bumper reinforcements absorb collision impact across a boarder area and strengthened body structure help to keep damage low level to large and expensive parts.

In the current era of environmental protection we fully take into consideration and actively implement the re-use and recycling of resources and parts as well as the reduction of environmentally harmful materials.



Recycling Activities

Recycling of plastic materials as well as the conventional recycling of metal materials are aggressively promoted.

TSOP, TPO & TPU

TSOP: The Super Olefin Polymer, TPO: Thermoplastic olefin, TPU: Thermoplastic polyurethane

TSOP, TPO and TPU, which have excellent recycling characteristics, are used in many parts. Additionally, chlorine use is reduced as much as possible.

A sample of parts made of TSOP, TPO and TPU:

- Front & rear bumper covers
- Lower door molding
- Rocker molding
- Pillar garnish (Front, center)
- Roof side inner garnish
- Door Trim
- Instrument Panel
- Door Scuff Plate
- Rear Seat Side Garnish
- Door Flame Garnish



189MO40

Use of Recycled Materials

Recycled materials are used in the following parts:

- Luggage trims
- Lower instrument under cover, No. 1 & No. 2
- Engine under cover No. 2
- Front fender splashshield
- Engine under cover bracket
- Dash silencers



189MO41



Reducing the Use of Environmentally Harmful Materials (Lead)

The use of lead is considerably cut back.

Parts in which use of lead has been reduced:

- Radiator**
- Heater core**
- Battery cable terminals**
- Fuel tank**
- Wire harness covering**
- Light bulbs and window glass**
- Drive shaft lubricating grease**

LS430

OUTLINE OF NEW FEATURES

The following changes are made for the 2002 model year.

1. Engine

The logic of the ECM for detecting evaporative emission leakage has been changed to increase the detection range from the 2001 LS430. In conjunction with this change, the DTC (Diagnostic Trouble Code) P0442 has been added.

No changes have been made to the system configuration.

2. Door Lock Control System

The One-motion open function has been added to the passenger's side. The function which enables the passenger to unlock the passenger's door by pulling the passenger's door inside handle.

3. SRS Airbag System

- Dual-stage SRS airbag system has been adopted for driver airbag, that controls the airbag deployment output optimum by judging the extent of impact, seat position and whether or not the seat belt is fasten. In accordance with the adoption of the Dual-stage SRS airbag system, a seat position sensor has been added for the driver seat.
- The Airbag sensor assembly transmits the airbag deployment signal to the door lock ECU via the BEAN (Body Electronics Area Network) and sends in addition directly the airbag deployment signal to the door lock ECU via Theft deterrent ECU for collision door lock release control.

4. Compass

A compass display has been adopted on the Inside rear view mirror to the Canada models without GPS (Global Positioning System) voice navigation system.

5. Multi Display

The GPS voice navigation system has been added to the Canada models as optional equipment.

6. Audio

The voice recognition function has been added which this function enables the operation of the AM/FM radio, cassette player and 6-CD automatic changer.

EXTERIOR APPEARANCE

1

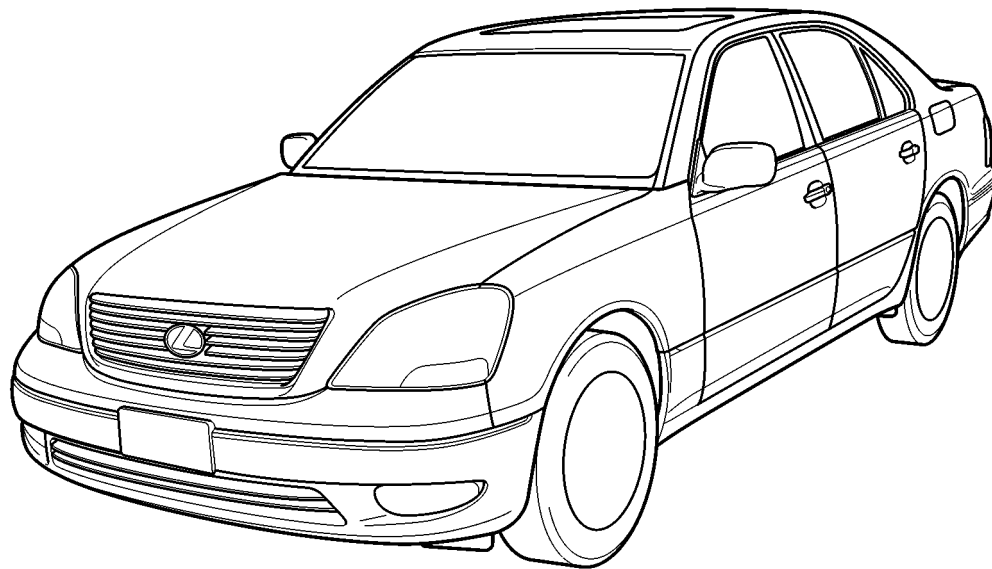

213LS03

LS430

OUTLINE OF NEW FEATURES

The flagship sedan of the LEXUS lineup, the LS430 is the ultimate sedan into which all automotive technology has been concentrated.

The following changes are made for the 2003 model year.

1. Tire and Disc Wheel

- The 225/55R17 size tire has been changed from optional to standard equipment.
- The size 225/60R16 tire has been discontinued.

2. 3UZ-FE Engine

To comply with the OBD-II regulations, all the DTCs (Diagnostic Trouble Codes) have been made to correspond to the SAE controlled codes. Some of the DTCs have been further divided into smaller detection areas than in the past, and new DTCs have been assigned to them.

For details, see the General 2003 Features section.

3. Stabilizer Bar

The front stabilizer bar has been changed from the solid type to the hollow type.

◀ **KNOCK SENSOR (FLAT TYPE)**

1. General

In the conventional type knock sensor (resonant type), a vibration plate which has the same resonance point as the knocking frequency of the engine is built in and can detect the vibration in this frequency band.

On the other hand, a flat type knock sensor (non-resonant type) has the ability to detect vibration in a wider frequency band from about 6 kHz to 15 kHz, and has the following features.

- The engine knocking frequency will change a bit depending on the engine speed. The flat type knock sensor can detect the vibration even when the engine knocking frequency is changed. Thus the vibration detection ability is increased compared to the conventional type knock sensor, and a more precise ignition timing control is possible.

--- : Resonance Characteristic of Conventional Type

— : Resonance Characteristic of Flat Type

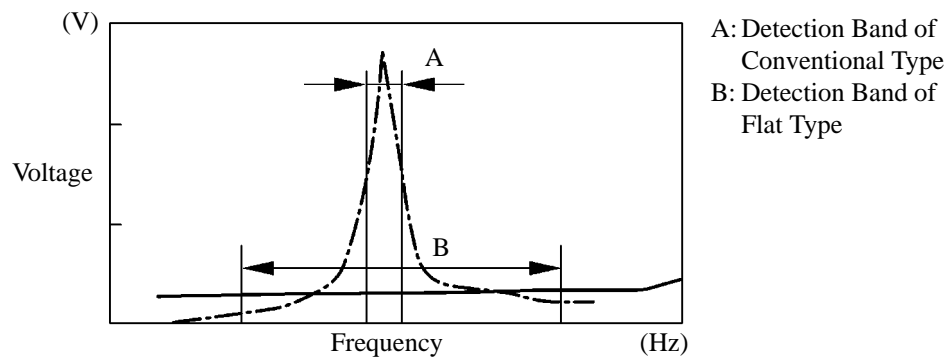

A: Detection Band of Conventional Type
B: Detection Band of Flat Type

Characteristic of Knock Sensor

214CE04

2. Construction

- The flat type knock sensor is installed on the engine through the stud bolt installed on the cylinder block. For this reason, a hole for the stud bolt is in the center of the sensor.
- Inside of the sensor, a steel weight is located on the upper portion and a piezoelectric element and is located under the weight through the insulator.
- The open/short circuit detection resistor is integrated.

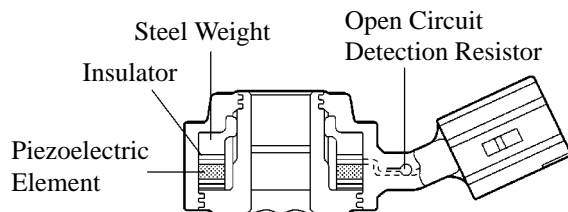

**Flat Type Knock Sensor
(Non-Resonant Type)**

214CE01

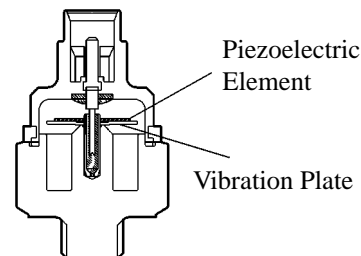

**Conventional Type Knock Sensor
(Resonant Type)**

214CE02

3. Operation

The knocking vibration is transmitted to the steel weight and its inertia applies pressure to the piezoelectric element. The action generates electromotive force.

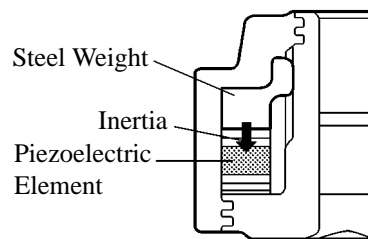

214CE08

2

4. Open/Short Circuit Detection Resistor

During ignition ON, the open/short circuit detection resistor in the knock sensor and the resistor in the ECM keep the voltage at the terminal KNK1+ or KNK2+ constant.

An IC (Integrated Circuit) in the ECM is always monitoring the voltage of the terminal KNK1+ or KNK2+. If the open/short circuit occurs between the knock sensor and the ECM, the voltage of the terminal KNK1+ or KNK2+ will change and the ECM detects the open/short circuit and stores DTC (Diagnostic Trouble Codes) P0325.

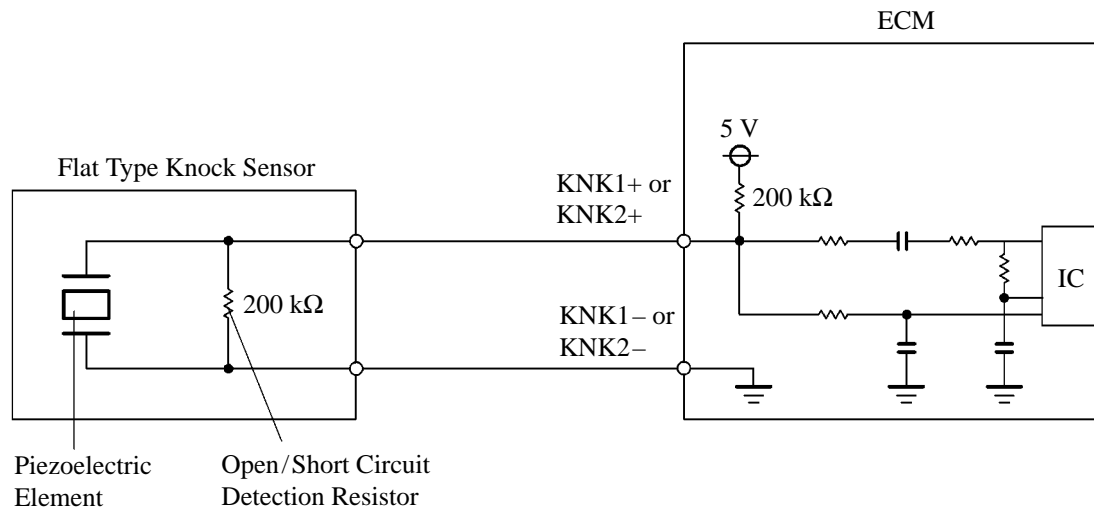

214CE06

Service Tip

In accordance with the adoption of an open/short circuit detection resistor, the inspection method for the sensor has been changed. For details, see the 2004 LEXUS LS430 Repair Manual (Pub. No. RM1048U).

LS430

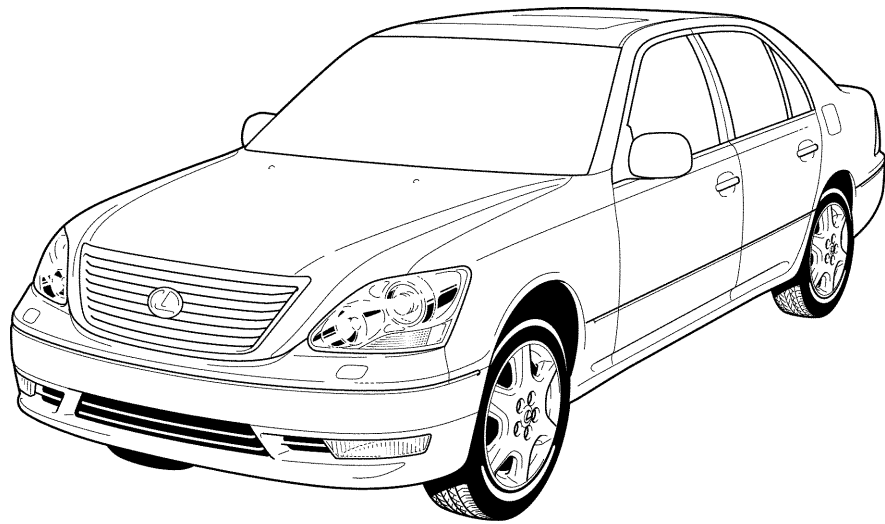

259LSW50

LS430

OUTLINE OF NEW FEATURES

The following changes are made for the 2005 model year.

1. 3UZ-FE Engine

The ECM outputs the VIN (Vehicle Identification Number) to the hand-held tester for OBD II (On-Board Diagnosis II).

2. Tires

All-season type is added to the optional 245/45R18 tires.

3. LEXUS Link System

Cellular networks in the United States are changing from analog to digital. Therefore, LEXUS stopped production of analog LEXUS Link system. However, the microphone for the LEXUS link system is continued for use with voice recognition.

NEW FEATURES

● 3UZ-FE ENGINE (ENGINE CONTROL SYSTEM)

1. General

The engine control system of the 3UZ-FE engine on the '06 LS430 has the following system.

System	Outline	Model	
		'06 Model	'05 Model
SFI (Sequential Multiport Fuel Injection)	An L-type SFI system directly detects the intake air mass with a hot wire type mass air flow meter.	◀	◀
ESA (Electronic Spark Advance)	Ignition timing is determined by the ECM based on signals from various sensors. The ECM corrects ignition timing in response to engine knocking.	◀	◀
ETCS-i (Electronic Throttle Control System-intelligent)	Optimally controls the throttle valve opening in accordance with the amount of accelerator pedal effort and engine and vehicle conditions.	◀	◀
VVT-i (Variable Valve Timing-intelligent)	Controls the intake camshaft to optimal valve timing in accordance with the engine condition.	◀	◀
ACIS (Acoustic Control Induction System)	The intake air passages are switched according to the engine speed and throttle valve opening angle to provided high performance in all speed ranges.	◀	◀
Cooling Fan Control	The ECM steplessly controls the speed of the fans in accordance with the engine coolant temperature, vehicle speed, engine speed, and air conditioning operation conditions.	◀	◀
Fuel Pump Control	<ul style="list-style-type: none"> The ECM controls fuel pump speed by switching the circuit to the fuel pump resistor. The fuel pump is stopped, when the SRS airbag is deployed in front, side, or rear side collision. 	◀	◀
Oxygen Sensor Heater Control	Maintains the temperature of the oxygen sensor at an appropriate level to increase accuracy of detection of the oxygen concentration in the exhaust gas.	◀	◀
Evaporative Emission Control [See page 9]	The ECM controls the purge flow of evaporative emission (HC) in the charcoal canister in accordance with engine conditions.	◀	◀
	Using three VSVs and a vapor pressure sensor, the ECM detects any evaporative emission leakage occurring between the fuel tank and the charcoal canister through pressure changes in the fuel tank.	—	◀
	Approximately five hours after the ignition switch has been turned OFF, the ECM operates the leak detection pump to detect any evaporative emission leakage occurring between the fuel tank and the charcoal canister through pressure changes in the fuel tank.	◀	—

(Continued)

System	Outline	Model	
		'06 Model	'05 Model
Air Conditioning Cut-off Control	By turning the A/C compressor ON or OFF in accordance with the engine condition, drivability is maintained.	◀	◀
Engine Immobilizer	Prohibits fuel delivery and ignition if an attempt is made to start the engine with an invalid ignition key.	◀	◀
Diagnosis [See page 21]	When the ECM detects a malfunction, the ECM diagnoses and memorizes the failed section.	◀	◀
Fail-safe	When the ECM detects a malfunction, the ECM stops or controls the engine according to the data already stored in the memory.	◀	◀

2. Construction

The configuration of the engine control system in the 3UZ-FE engine is shown in the following chart.

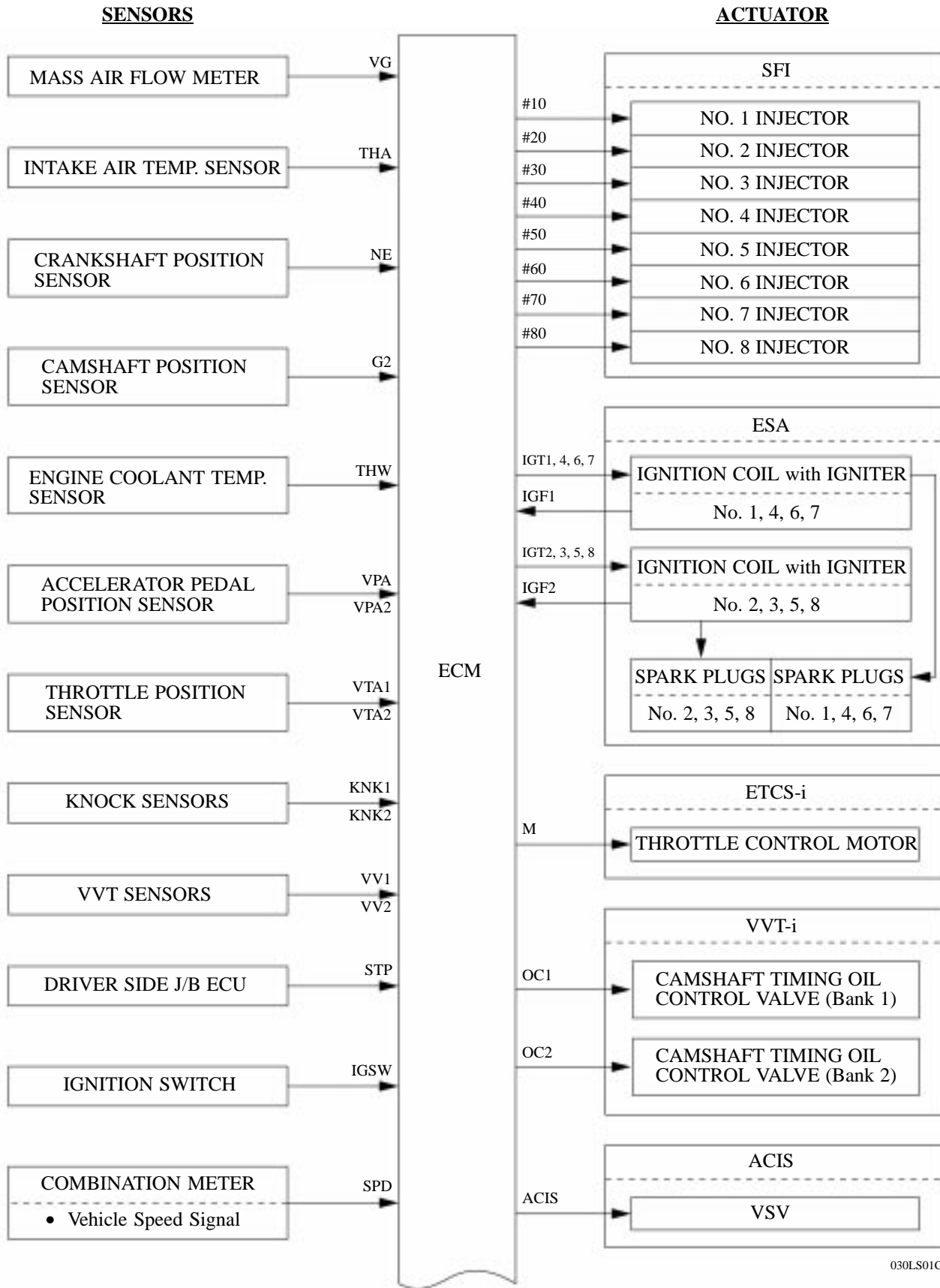

(Continued)

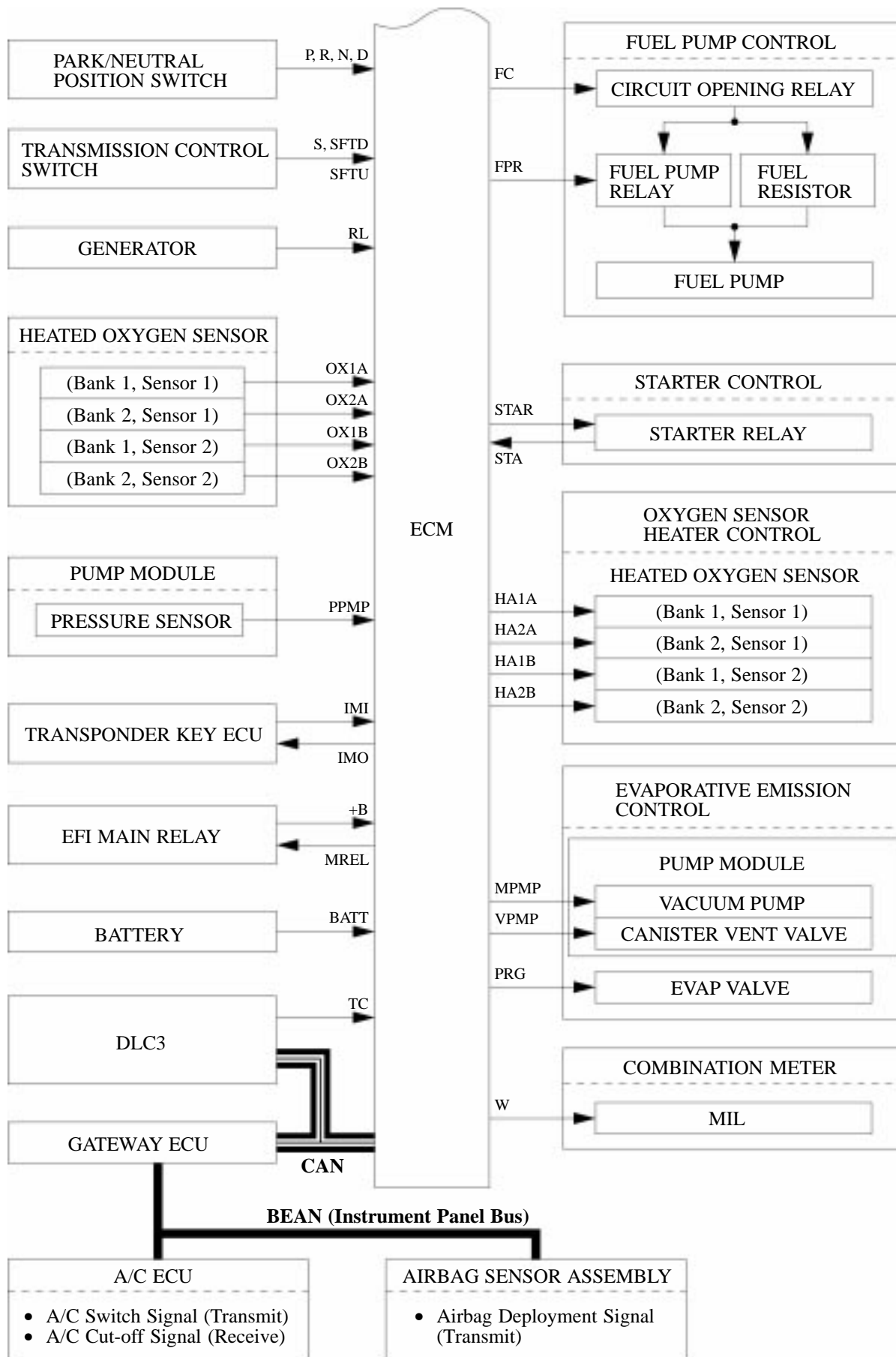

3. Engine Control System Diagram

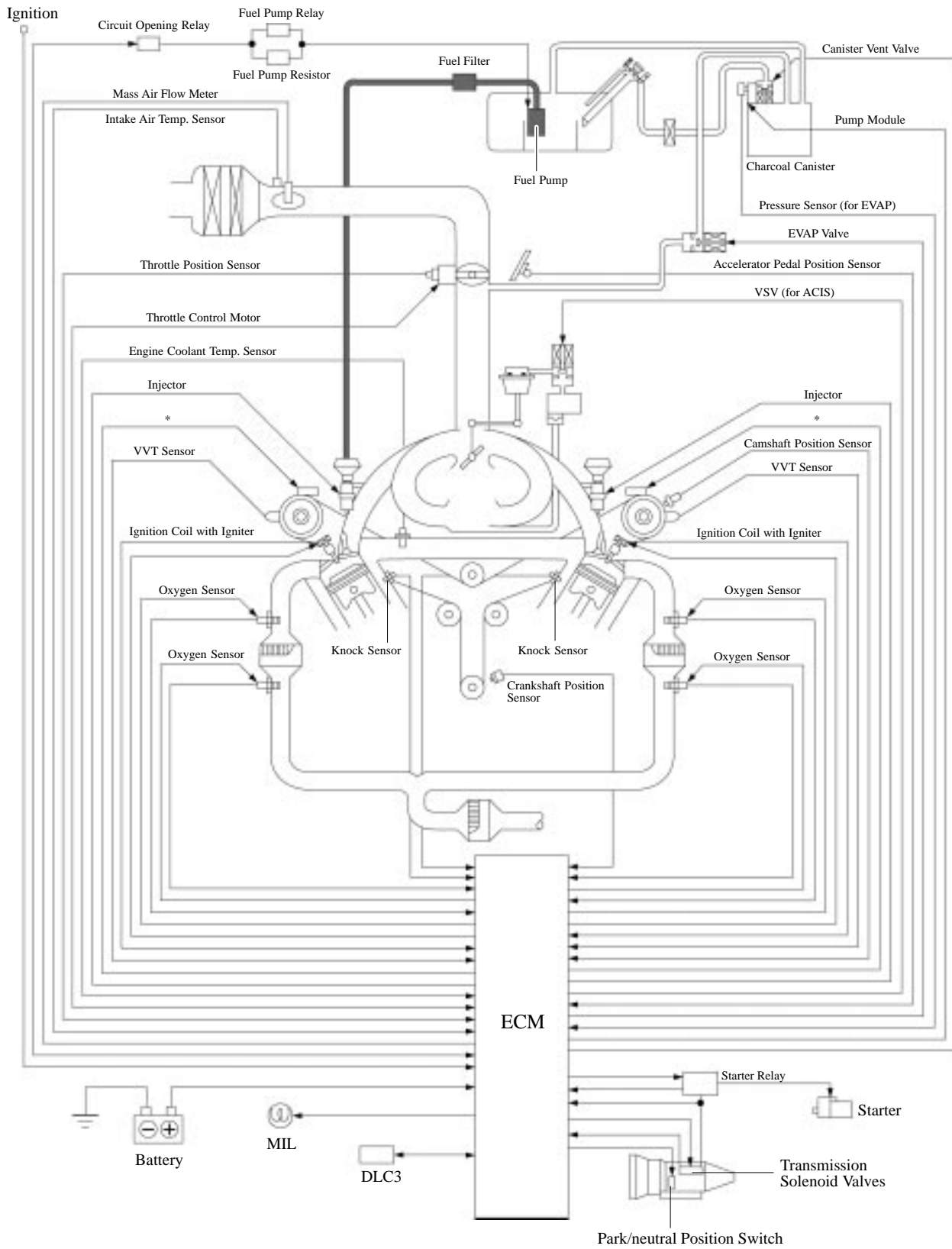

*: Camshaft Timing Oil Control Valve

4. Evaporative Emission Control System

General

The evaporative emission control system prevents the vapor gas that is created in the fuel tank from being released directly into the atmosphere.

- The charcoal canister stores the vapor gas that has been created in the fuel tank.
- The ECM controls the EVAP valve in accordance with the driving conditions in order to direct the vapor gas into the engine, where it is burned.
- In this system, the ECM checks the evaporative emission leak and outputs DTC (Diagnostic Trouble Codes) in the event of a malfunction. An evaporative emission leak check consists of an application of a vacuum pressure to the system and monitoring the changes in the system pressure in order to detect a leakage.
- This system consists of an EVAP valve, charcoal canister, refueling valve, pump module, and ECM.
- An ORVR (Onboard Refueling Vapor Recovery) function is provided in the refueling valve.
- The pressure sensor has been included to the pump module.
- An air filter has been provided on the fresh air line. This air filter is maintenance-free.
- The EVAP service port has been removed.
- The following are the typical conditions for enabling an evaporative emission leak check:

Typical Enabling Condition	<ul style="list-style-type: none"> • Five hours have elapsed after the engine has been turned OFF*. • Altitude: Below 2400 m (8000 feet) • Battery Voltage: 10.5 V or more • Ignition switch: OFF • Engine Coolant Temperature: 4.4 to 35°C (40 to 95°F) • Intake Air Temperature: 4.4 to 35°C (40 to 95°F)
----------------------------	---

*: If engine coolant temperature does not drop below 35°C (95°F), this time should be extended to 7 hours. Even after that, if the temperature is not less than 35°C (95°F), the time should be extended to 9.5 hours.

Service Tip

The pump module performs fuel evaporative emission leakage check. This check is done approximately five hours after the engine is turned off. So you may hear sound coming from underneath the vehicle near the luggage compartment for several minutes. It does not indicate a malfunction.

- Pinpoint pressure test procedure is adopted by pressurizing the fresh air line that runs from the pump module to the air filler neck. For details, see the 2006 LEXUS LS430 Repair Manual (Pub. No. RM00B0U).

System Diagram

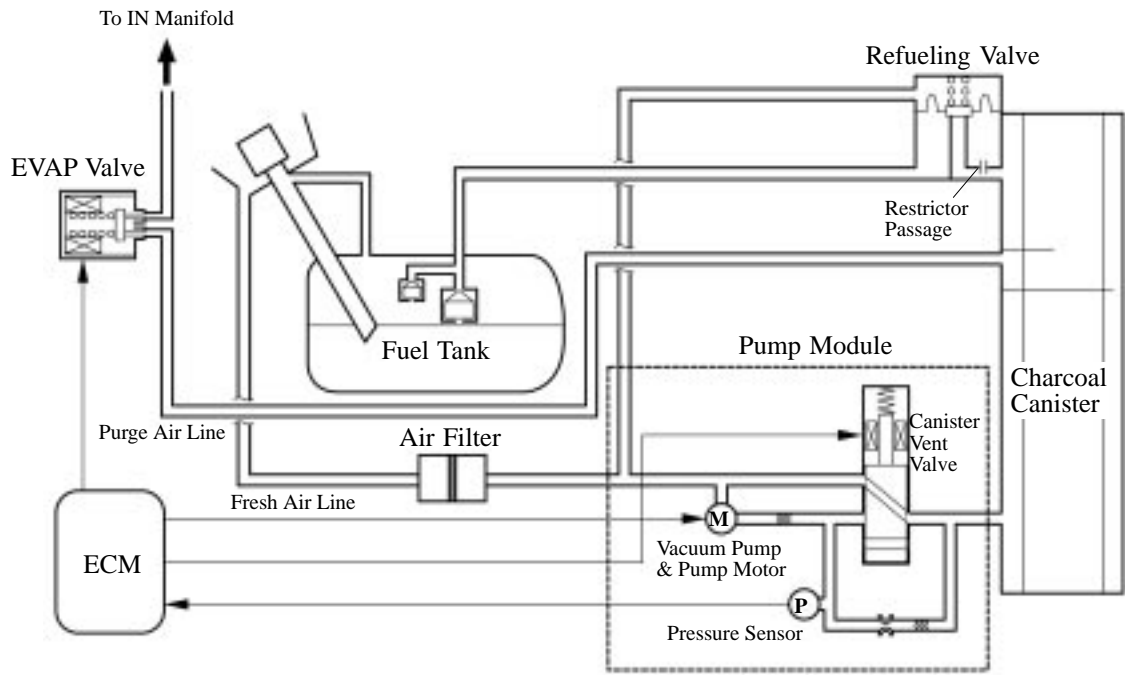

060XA15C

Layout of Main Component

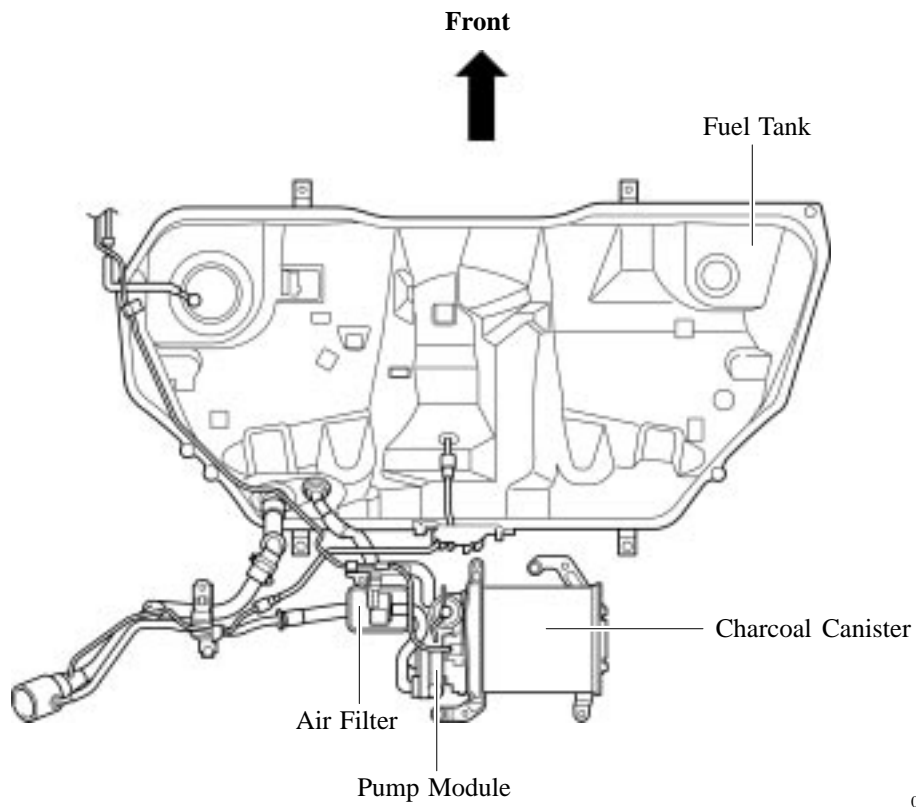

030LS04C

Function of Main Component

Component		Function
Charcoal Canister		Contains activated charcoal to absorb the vapor gas that is created in the fuel tank.
Refueling Valve		Controls the flow rate of the vapor gas from the fuel tank to the charcoal canister when the system is purging or during refueling.
	Restrictor Passage	Prevents a large amount of vacuum during purge operation or system monitoring operation from affecting the pressure in the fuel tank.
Fresh Air Line		Fresh air goes into the charcoal canister and the cleaned drain air goes out into the atmosphere.
Pump Module	Canister Vent Valve	Opens and closes the fresh air line in accordance with the signals from the ECM.
	Vacuum Pump & Pump Motor	Applies vacuum pressure to the evaporative emission system in accordance with the signals from the ECM.
	Pressure Sensor	Detects the pressure in the evaporative emission system and sends the signals to the ECM.
EVAP Valve		Opens in accordance with the signals from the ECM when the system is purging, in order to send the vapor gas that was absorbed by the charcoal canister into the intake manifold. In system monitoring mode, this valve controls the introduction of the vacuum into the fuel tank.
Air Filter		Prevents dust and debris in the fresh air from entering the system.
ECM		Controls the pump module and the EVAP valve in accordance with the signals from various sensors, in order to achieve a purge volume that suits the driving conditions. In addition, the ECM monitors the system for any leakage and outputs a DTC if a malfunction is found.

Construction and Operation

1) Refueling Valve

The refueling valve consists of chamber A, chamber B, and the restrictor passage. A constant atmospheric pressure is applied to chamber A.

- During refueling, the internal pressure of the fuel tank increases. This pressure causes the refueling valve to lift up, allowing the fuel vapors to enter the charcoal canister.
- The restrictor passage prevents the large amount of vacuum that is created during purge operation or system monitoring operation from entering the fuel tank, and limits the flow of the vapor gas from the fuel tank to the charcoal canister. If a large volume of vapor gas recirculates into the intake manifold, it will affect the air-fuel ratio control of the engine. Therefore, the role of the restrictor passage is to help prevent this from occurring.

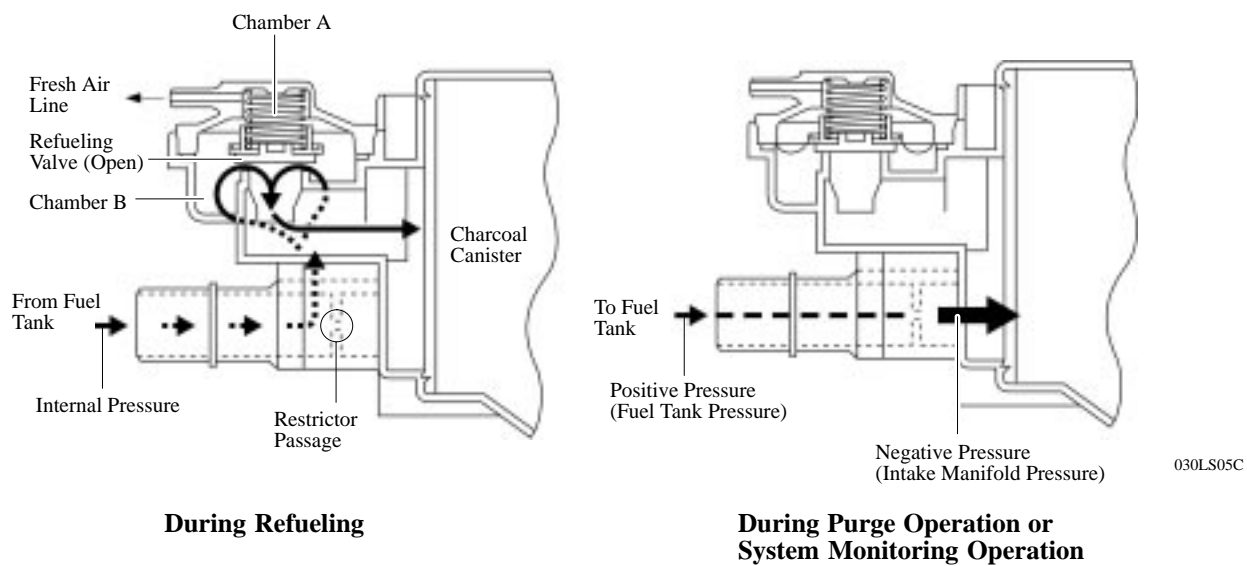

2) Fuel Inlet (Fresh Air Inlet)

In accordance with the change of structure of the evaporative emission control system, the location of a fresh air line inlet has been changed from the air cleaner section to the near fuel inlet. The fresh air from the atmosphere and drain air cleaned by the charcoal canister will go in and out of the system through the passage shown below.

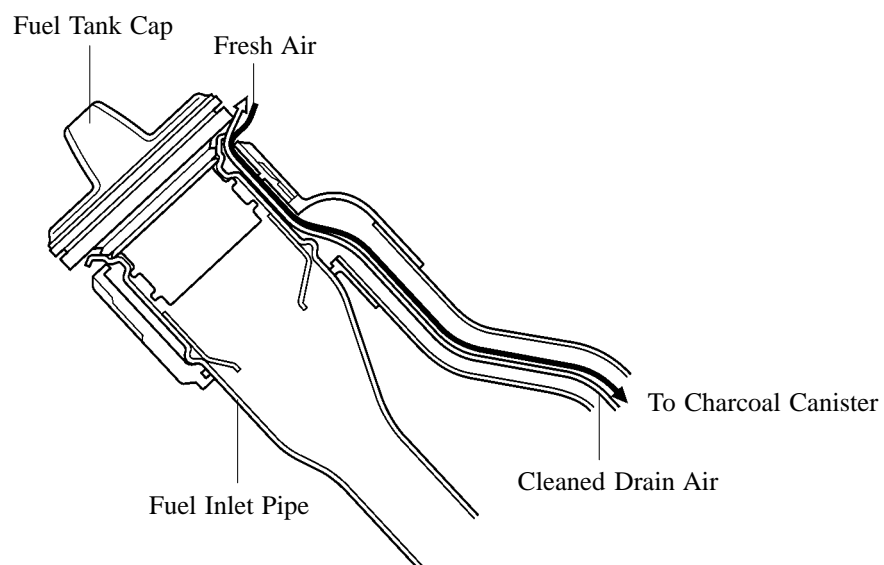

3) Pump module

Pump module consists of the canister vent valve, pressure sensor, vacuum pump, and pump motor.

- The canister vent valve switches the passages in accordance with the signals received from the ECM.
- A DC type brushless motor is used for the pump motor.
- A vane type vacuum pump is used.

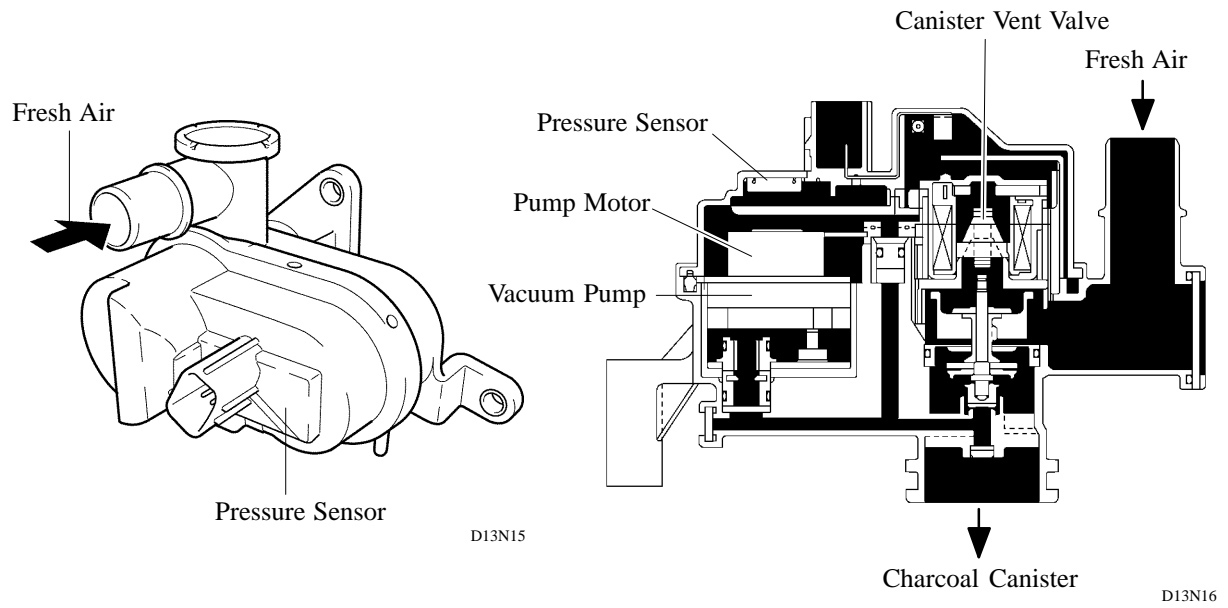

● Simple Diagram ◀

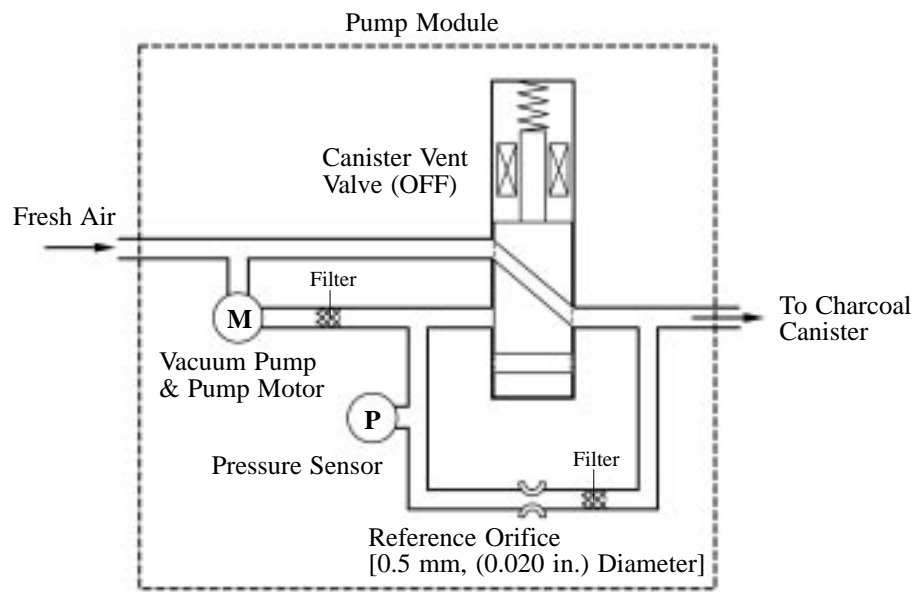

System Operation

1) Purge Flow Control

When the engine has reached predetermined parameters (closed loop, engine coolant temp. above 80°C (176°F), etc), stored fuel vapors are purged from the charcoal canister whenever the EVAP valve is opened by the ECM.

The ECM will change the duty ratio cycle of the EVAP valve, thus controlling purge flow volume. Purge flow volume is determined by intake manifold pressure and the duty ratio cycle of the EVAP valve. Atmospheric pressure is allowed into the charcoal canister to ensure that purge flow is constantly maintained whenever purge vacuum is applied to the charcoal canister.

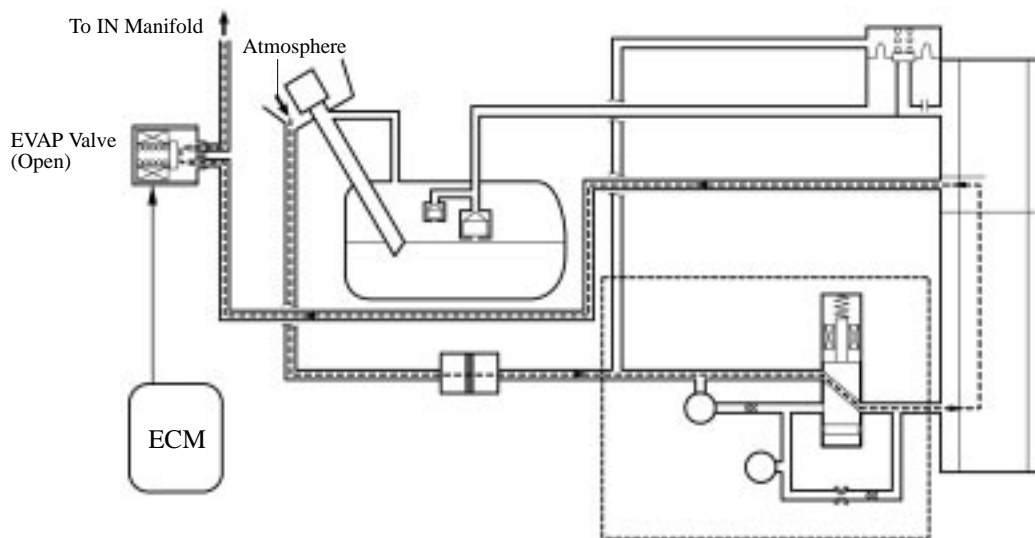

060XA17C

2) ORVR (On-Board Refueling Vapor Recovery)

When the internal pressure of the fuel tank increases during refueling, this pressure causes the diaphragm in the refueling valve to lift up, allowing the fuel vapors to enter the charcoal canister. Because the canister vent valve is always open (even when the engine is stopped) when the system is in a mode other than the monitoring mode, the air that has been cleaned through the charcoal canister is discharged outside the vehicle via the fresh air line. If the vehicle is refueled in system monitoring mode, the ECM will recognize the refueling by way of the pressure sensor, which detects the sudden pressure increase in the fuel tank, and will open the canister vent valve.

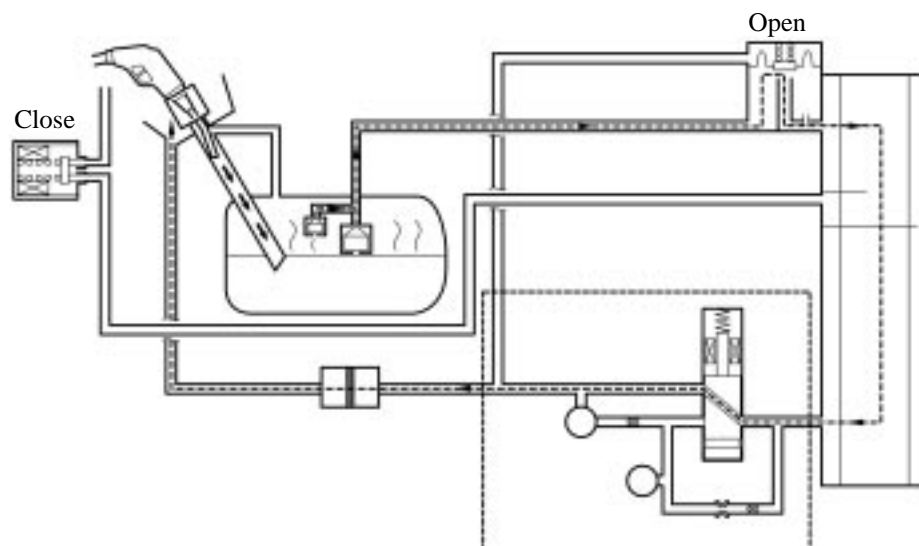

060XA18C

3) EVAP Leak Check

a. General

The EVAP leak check operates in accordance with the following timing chart:

• Timing Chart ◀

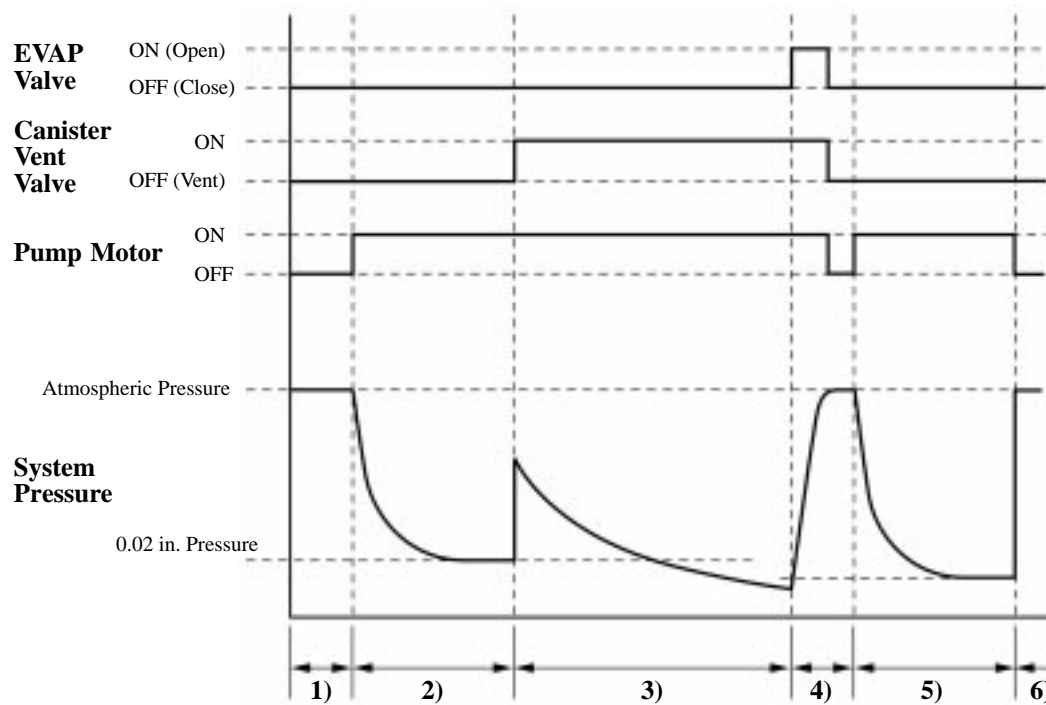

060XA19C

Order	Operation	Description	Time
1)	Atmospheric Pressure Measurement	ECM turns canister vent valve OFF (vent) and measures EVAP system pressure to memorize atmospheric pressure.	—
2)	0.02 in. Leak Pressure Measurement	Vacuum pump creates negative pressure (vacuum) through 0.02 in. orifice and the pressure is measured. ECM determines this as 0.02 in. leak pressure.	20 sec.
3)	EVAP Leak Check	Vacuum pump creates negative pressure (vacuum) in EVAP system and EVAP system pressure is measured. If stabilized pressure is larger than 0.02 in. leak pressure, ECM determines EVAP system has a leak. If EVAP pressure does not stabilize within 15 minutes, ECM cancels EVAP monitor.	Within 15 min.
4)	EVAP Valve Monitor	ECM opens EVAP valve and measure EVAP pressure increase. If increase is large, ECM interprets this as normal.	10 sec.
5)	Repeat 0.02 in. Leak Pressure Measurement	Vacuum pump creates negative pressure (vacuum) through 0.02 in. orifice and pressure is measured. ECM determines this as 0.02 in. leak pressure.	20 sec.
6)	Final Check	ECM measures atmospheric pressure and records monitor result.	—

b. Atmospheric Pressure Measurement

- 1) When the ignition switch is turned OFF, the EVAP valve and the canister vent valve are turned OFF. Therefore, the atmospheric pressure is introduced into the charcoal canister.
- 2) The ECM measures the atmospheric pressure through the signals provided by the pressure sensor.
- 3) If the measurement value is out of standards, the ECM actuates the vacuum pump in order to monitor the changes in the pressure.

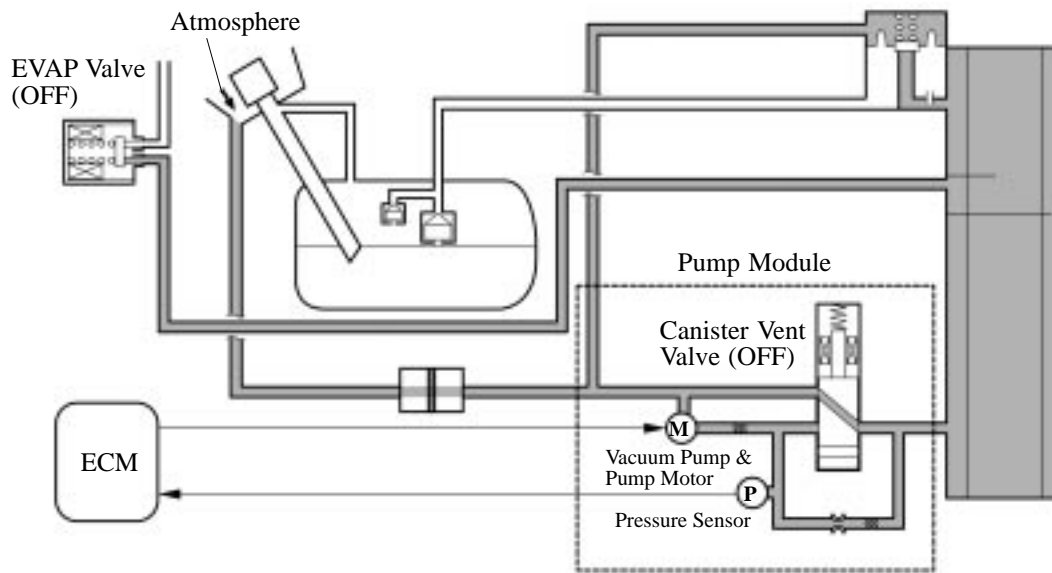

060XA20C

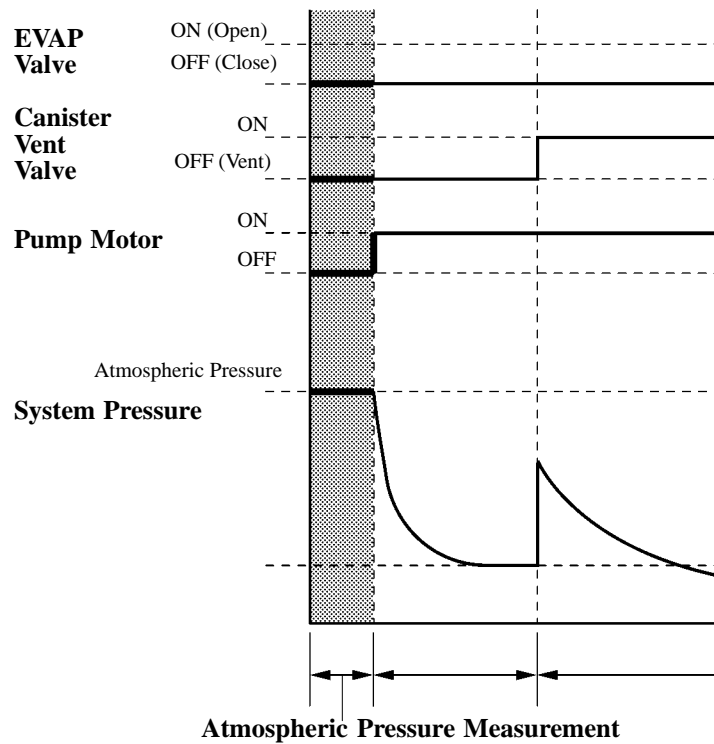

D13N22

c. 0.02 in. Leak Pressure Measurement

- 1) The canister vent valve remains off, and the ECM introduces atmospheric pressure into the charcoal canister and actuates the vacuum pump in order to create a negative pressure.
- 2) At this time, the pressure will not decrease beyond a 0.02 in. pressure due to the atmospheric pressure that enters through a 0.02 in. diameter reference orifice.
- 3) The ECM compares the logic value and this pressure, and stores it as a 0.02 in. leak pressure in its memory.
- 4) If the measurement value is below the standard, the ECM will determine that the reference orifice is clogged and store DTC (Diagnostic Trouble Code) P043E in its memory.
- 5) If the measurement value is above the standard, the ECM will determine that a high flow rate pressure is passing through the reference orifice and store DTCs (Diagnostic Trouble Codes) P043F, P2401 and P2402 in its memory.

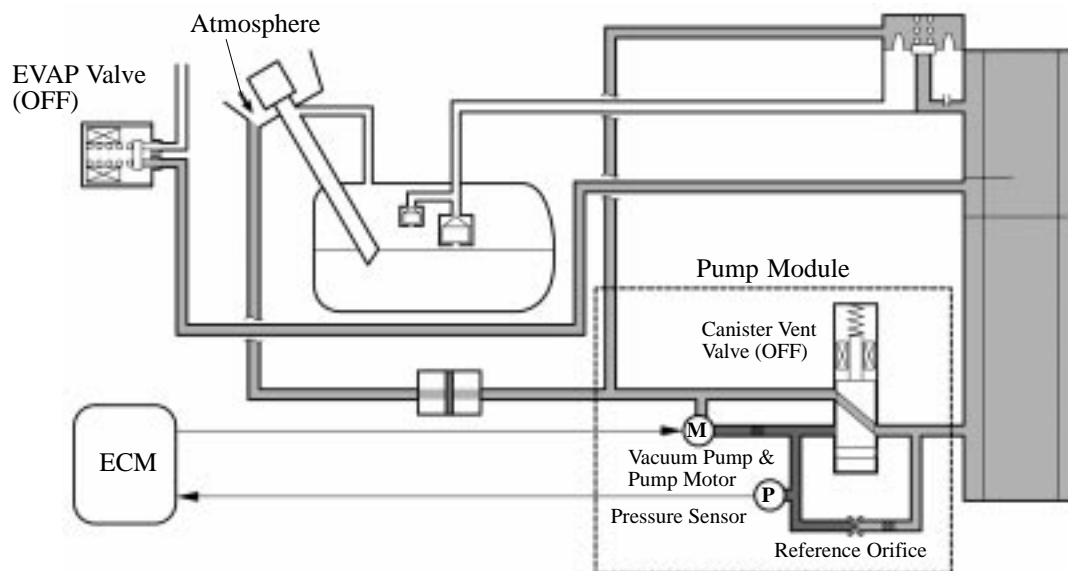

060XA21C

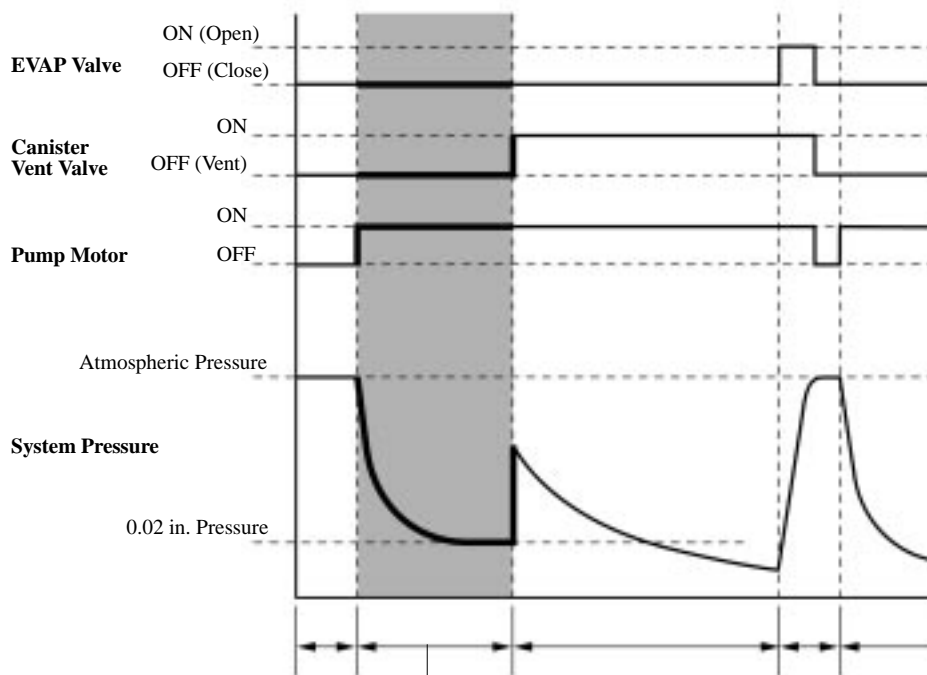

0.02 in. Pressure Measurement

060XA22C

d. EVAP Leak Check

- 1) While actuating the vacuum pump, the ECM turns ON the canister vent valve in order to introduce a vacuum into the charcoal canister.
- 2) When the pressure in the system stabilizes, the ECM compares this pressure and the 0.02 in. pressure in order to check for a leakage.
- 3) If the detection value is below the 0.02 in. pressure, the ECM determines that there is no leakage.
- 4) If the detection value is above the 0.02 in. pressure and near atmospheric pressure, the ECM determines that there is a gross leakage (large hole) and stores DTC P0455 in its memory.
- 5) If the detection value is above the 0.02 in. pressure, the ECM determines that there is a small leakage and stores DTC P0456 in its memory.

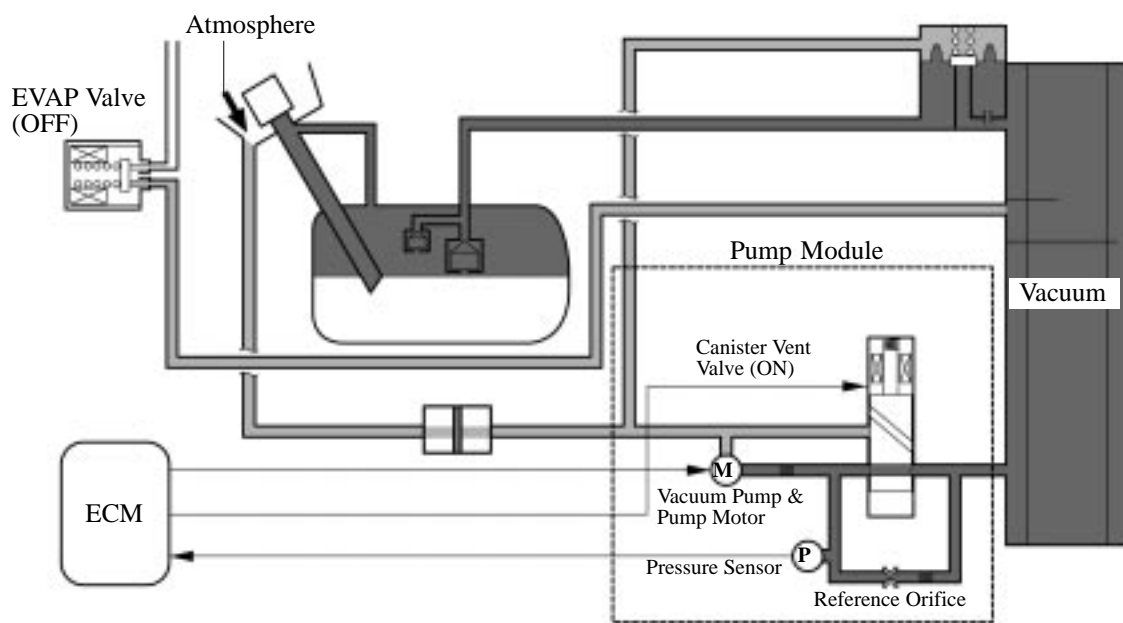

060XA23C

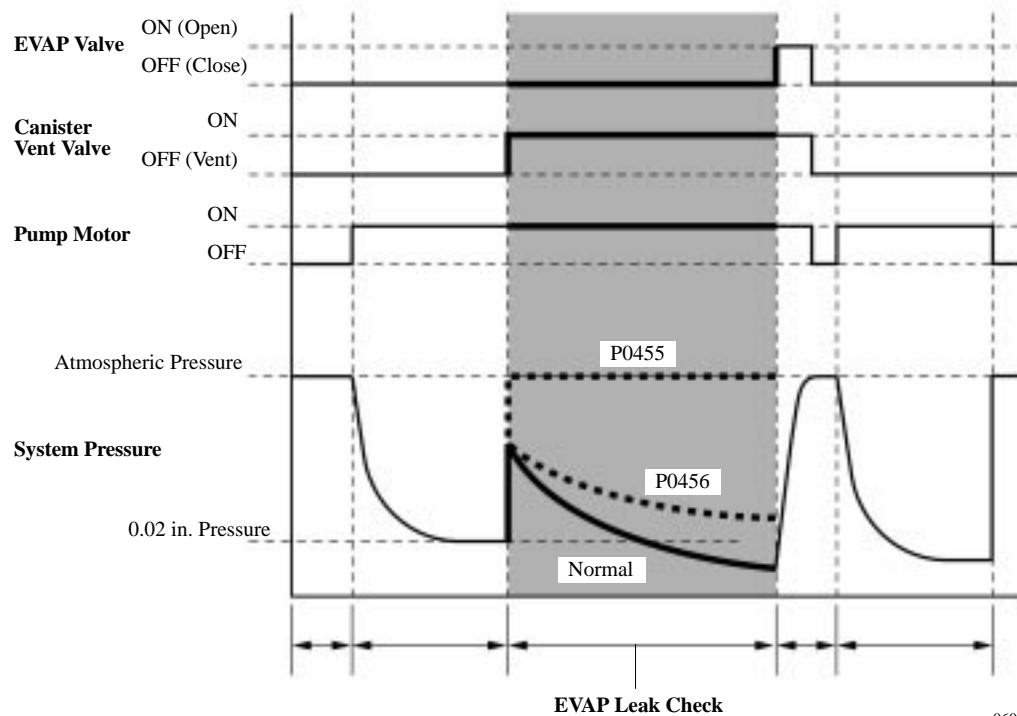

060XA24C

e. EVAP Valve Monitor

- 1) After completing an EVAP leak check, the ECM turns ON (open) the EVAP valve with the vacuum pump actuated, and introduces the atmospheric pressure from the intake manifold to the charcoal canister.
- 2) If the pressure change at this time is within the normal range, the ECM determines the condition to be normal.
- 3) If the pressure is out of the normal range, the ECM will stop the EVAP valve monitor and store DTC P0441 in its memory.

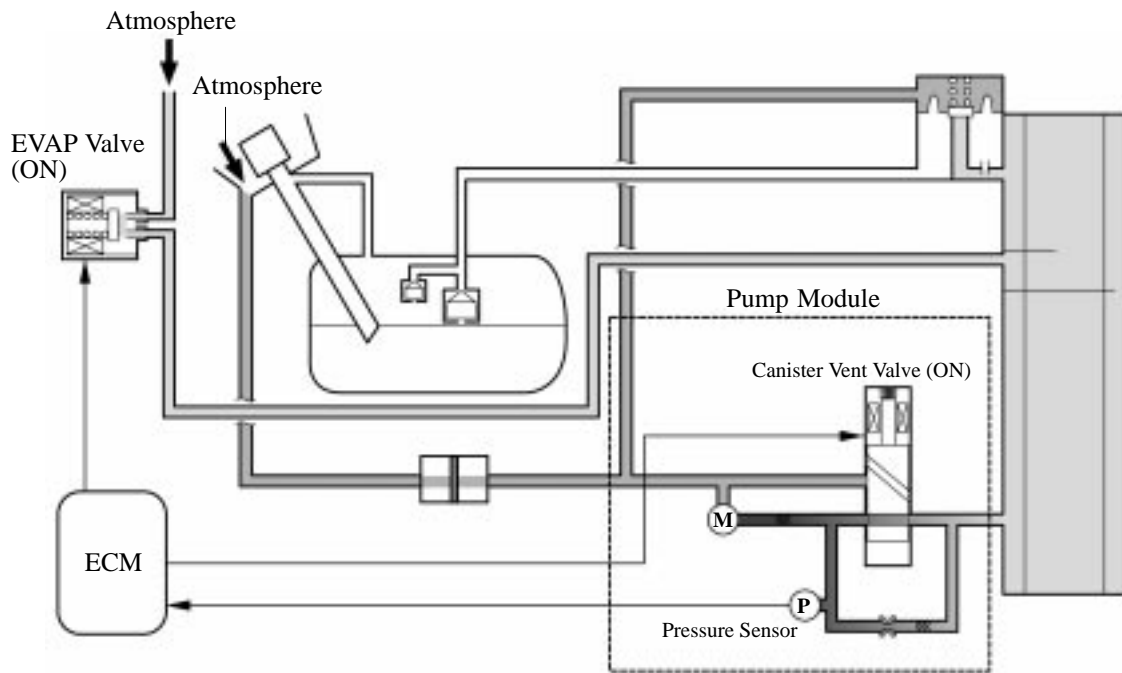

060XA25C

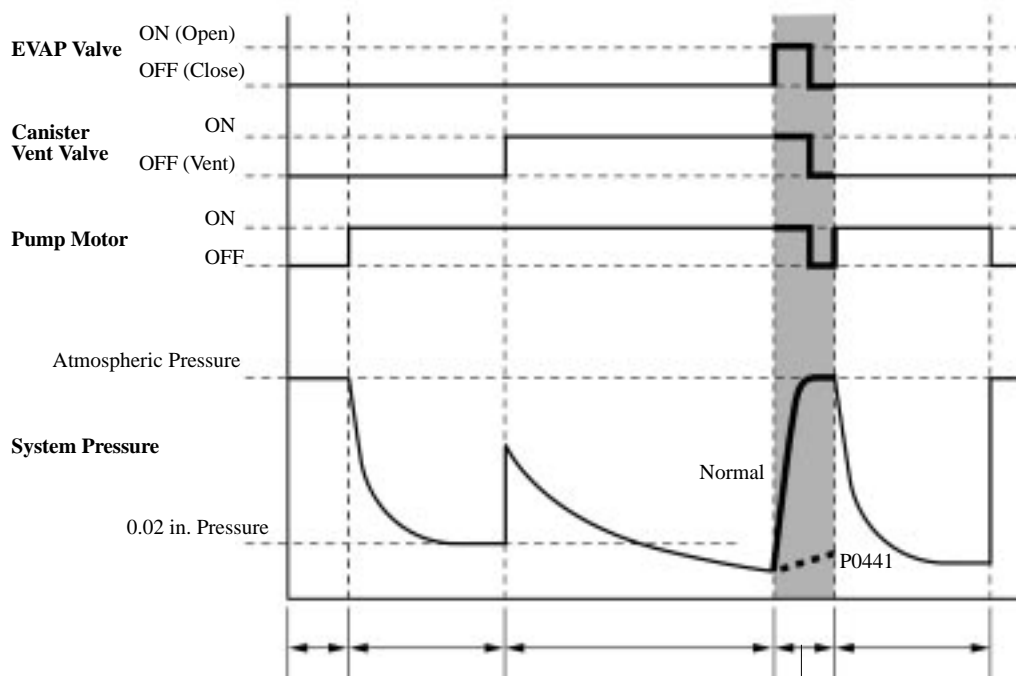

EVAP Valve Monitor

060XA26C

f. Repeat 0.02 in. Leak Pressure Measurement

- 1) While the ECM operates the vacuum pump, the EVAP valve and canister vent valve turns off and a repeat 0.02 in. leak pressure measurement is performed.
- 2) The ECM compares the measured pressure with the pressure during EVAP leak check.
- 3) If the pressure during the EVAP leak check is below the measured value, the ECM determines that there is no leakage.
- 4) If the pressure during the EVAP leak check is above the measured value, the ECM determines that there is a small leakage and stores DTC P0456 in its memory.

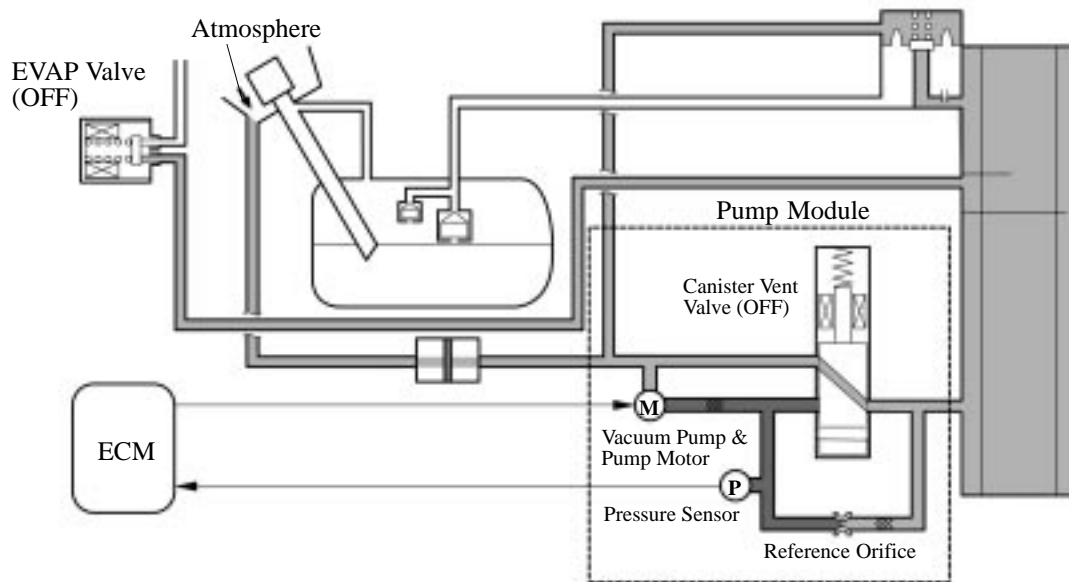

060XA27C

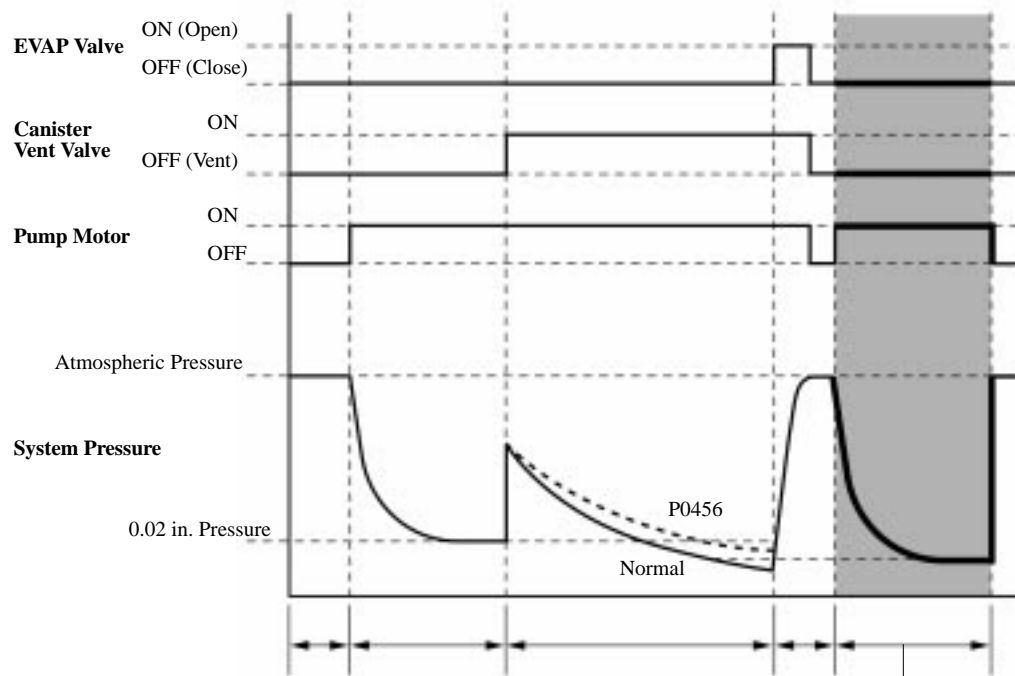

Repeat 0.02 in. Pressure Measurement

060XA28C

5. Diagnosis

The following DTCs (Diagnostic Trouble Codes) are added.

DTC	Detection Item	DTC	Detection Item
P043E	Evaporate Emission System Reference Orifice Clog Up	P2402	Evaporative Emission System Leak Detection Pump Control Circuit High
P043F	Evaporate Emission System Reference Orifice High Flow	P2419	Evaporate Emission System Switching Valve Control Circuit Low
P0450	Evaporative Emission Control System Pressure Sensor/Switch	P2420	Evaporate Emission System Switching Valve Control Circuit High
P2401	Evaporative Emission System Leak Detection Pump Control Circuit Low	P2610	ECM/PCM Internal Engine Off Timer Performance